

LAWS OF TRINIDAD AND TOBAGO

MOTOR VEHICLES AND ROAD TRAFFIC ACT

CHAPTER 48:50

Act				
42 of 1934				
Amended by				
2 of 1936	20 of 1953	15 of 1968	20 of 1978	17 of 1986
10 of 1937	47 of 1956	3 of 1969	21 of 1978	*11 of 1988
37 of 1938	35 of 1957	146/1969	28 of 1978	37 of 1989
28 of 1944	197/1957	2/1973	14 of 1979	9 of 1990
34 of 1944	115/1958	11/1974	47 of 1980	4 of 1992
24 of 1945	11 of 1959	13/1974	185/1980	6 of 1992
13 of 1946	12 of 1961	27/1974	2 of 1982	6 of 1993
40 of 1946	11 of 1963	6 of 1974	8 of 1982	3 of 1994
2 of 1948	2/1963	5 of 1975	146/1982	5 of 1995
33 of 1948	21/1963	6/1975	3/1983	8 of 1996
10 of 1949	32 of 1964	31 of 1976	20 of 1983	9 of 1997
37 of 1949	11 of 1965	6 of 1977	157/1983	*25 of 1997
30 of 1951	27/1966	44 of 1977	4/1985	35 of 1998
32 of 1951	36 of 1967	†8 of 1978	23/1985	21 of 2000
2 of 1952	2/1968	17 of 1978	198/1985	22 of 2000
30 of 1952	6/1968	19 of 1978	1 of 1986	2 of 2002
47 of 1952			3/1986	

*See Note on page 4

†This Act was validated by Act No. 21 of 1978

Current Authorised Pages

<i>Pages</i>	<i>Authorised</i>
<i>(inclusive)</i>	<i>by L.R.O.</i>
1-395	.. 1/2006

LAWS OF TRINIDAD AND TOBAGO

2

Chap. 48:50

Motor Vehicles and Road Traffic

Index of Subsidiary Legislation

	<i>Page</i>
Motor Vehicles and Road Traffic Regulations (G 1.6.44)... ..	100
Safety Helmets Notification (GN 137/1978)	233
Special Speed Limits Order (GN 210/1979)	234
Speed Limits (Built-Up Areas) Order (GN 209/1979)	236
Special Speed Limits (Bridges) Order (GN 46/1957)	243
Road Traffic (Prohibited Parking) Order (GN 206/1979)	244
Miscellaneous Roads (Unilateral Parking) Order (GN 207/1979)	253
Miscellaneous Roads (Unilateral Alternate Parking) Order (GN 208/1979)	260
Private Motor Cars (Parking Places) Order (GN 214/1979)	275
Public Stands (Taxis) Parking Order (GN 212/1979)	279
Public Stands (Motor Omnibuses) Parking Order (GN 213/ 1979)	289
Goods Vehicles Stands Parking Order (GN 215/1979)	292
Parking on Dual Carriage-ways Order (GN 216/1979)	293
Queen's Park Savannah Parking Order (GN 73/1966)	294
Independence Square (Parking of Vehicles) Order (GN 220/1979)	295
South Quay (Parking of Vehicles) Order (GN 219/1979)	296
Broadway (Parking of Vehicles) Order (GN 218/1979)	298
One-Way Traffic Order (GN 211/1979)... ..	299
Eastern Main Road Traffic Order (GN 58/1976)	310
Beetham Highway Order (GN 60/1976)... ..	313
Restriction of Parking (Public Buildings) Order (GN 56/1963)	314
Experimental Traffic (Priority Bus Route) Regulations (GN 181/1977)	315
Public Stand (Maxi-Taxi) Parking Order (LN 141/1981)	317
Traffic Restriction (Queen's Park Savannah Reticulation) Order (LN 147/1981)	318
Traffic Restriction (San Fernando) Order (LN 152/1981)	323
Notice of Exemption from Requirement to hold a Driver's Permit issued in a Foreign Country	327
Traffic Control Regulations (LN 90/1993)	329
Motor Vehicles (Seat Belt Assemblies) Regulations (LN 210/1994)	341

LAWS OF TRINIDAD AND TOBAGO

Motor Vehicles and Road Traffic

Chap. 48:50

3

Traffic Signs and Pedestrian Crossings Order (LN 1/1993)	346
Traffic Control Taxi Stand Location Order (LN 113/1988)	366
Port-of-Spain Transit Centre (Taxi Stand) Order (LN 226/1997)	372
Port-of-Spain Transit Centre (Public Service Vehicle Station) Regulations (LN 227/1997)	378
Priority Bus Route (Traffic Control) Order (LN 99/1988)	390
Priority Bus Route (Special Roads Toll) Regulations (LN 75/1988)	393

Note on Legal Notice No. 197/1999

A. (1) Regulation 3(k) of the Motor Vehicles and Road Traffic (Amendment) Regulations, 1999 (LN 197/1999) inserted the following Part, viz., “PART II—Authorised Examiners and Premises”.

(2) The Motor Vehicles and Road Traffic Regulations already contained a Part II and the new Part II viz., “PART II—Authorised Examiners and Premises”, inserted by LN 197/1999 was renumbered as “Part VA”.

B. Legal Notice No. 197/1999 was validated by Act No. 9 of 2001.

Note on Omissions

The following Subsidiary Legislation have been omitted:

- (a) The Motor Vehicles and Road Traffic (Exemption from payment of Registration Fee) Order 1991 (LN 35/1991 (*made under section 16 (2) of the Act*).
- (b) The Remittance of Transfer Tax on Motor Vehicles (BWIA International Airways Limited) Order 1995 (LN 65/1995) (*made under section 19E of the Act*).
- (c) Traffic Control Orders (*made under section 65 of the Act*).
- (d) Traffic Control (Experimental Scheme) Regulations (*made under section 67 of the Act*).
- (e) Traffic Restrictions (Temporary Provisions) Orders (*made under section 68 of the Act*).

For references to the above Subsidiary Legislation—See the Current Edition of the Consolidated Index of Acts and Subsidiary Legislation of Trinidad and Tobago.

Note on Application

(1) Section 10 of the Motor Omnibus Concessions (Acquisition of Undertakings) Act 1964 (Act No. 32 of 1964) provided that nothing contained in section 100 of this Act or any Regulations made thereunder which relates to the granting or operation of concessions shall apply to motor omnibuses operated by Government under that Act (i.e., Act No. 32 of 1964).

(2) The United States Defence Area (Agreement) Ordinance 1961 (Ord. No. 12 of 1961) (*See in particular sections 7, 8, 9, 11 and 17*) grants certain exemptions from the provisions of this Act.

Note on Metrication

In this Chapter the laws have been metricised. [*See* paragraph 12 of the Second Schedule to the Law Revision Act (Ch. 3:03) and LN 185/1980].

Note on Act No. 11 of 1988

See section 27 of Act No. 11 of 1988 for validation of charges for certain vehicle licences.

Note on Act No. 25 of 1997

See section 45 of Act No. 25 of 1997 for validation of acts and things purported to be done between October 01, 1996 and September 16, 1997.

Note on section 61A of the Act

Clause 3 of the Provisional Collection of Taxes Order (Legal Notice No. 213/2001) provides as follows:

“3. The Motor Vehicles and Road Traffic Act is amended by repealing section 61A and replacing it as follows:

‘61A. (1) Subject to subsection (3), an applicant for the issue of a new driving permit who is the holder of a permit which expired, shall pay to the Licensing Authority prior to the issue of the new permit—

- (a) the sum of two hundred dollars, where the period from the date of expiration to the date of submission of the application is six months or less;
- (b) the sum of five hundred dollars, where the period from the date of expiration to the date of submission of the application is more than six months but does not exceed three years;
- (c) one thousand dollars, where the period from the date of expiration to the date of submission of the application is more than three years but does not exceed five years.

(2) An applicant who was absent from Trinidad and Tobago during the period specified in subsection (1)(b) or (c), shall pay to the Licensing Authority the sum of two hundred dollars.

(3) An applicant for the issue of a new driving permit who is the holder of a permit which expired for a period which exceeds five years, shall, whether such period is spent in or out of Trinidad and Tobago, be required to produce a certificate of having passed a driving test in accordance with section 47 and shall pay to the Licensing Authority the sum of two hundred dollars prior to the issue of the new permit.' ”.

N.B. No subsequent Finance Act was passed to give effect to clause 3 of LN 213/2001.

CHAPTER 48:50

MOTOR VEHICLES AND ROAD TRAFFIC ACT

ARRANGEMENT OF SECTIONS

SECTION

1. Short title.

PART I

GENERAL

2. Interpretation.
3. Trinidad Transport Board.
4. Appointment of Transport Commissioner, Assistant Transport Commissioner, etc.
- 4A. Minister to approve forms, certificates and procedures for registration of vehicles.
5. Transport Officers to have powers, etc., of members of the Police Service.
6. Precept of appointment.
7. Equipment.
8. *(Repealed by Act No. 25 of 1997).*
9. Penalty for assaulting or obstructing Transport Officer.
10. Power to stop and inspect vehicles.
- 10A. Appointment and functions of a Traffic Warden.

PART II

REGISTRATION OF MOTOR VEHICLES

11. Motor vehicle registers.
12. Registration of motor vehicles.
13. Examination of motor vehicles.
14. Motor vehicles tax.
15. Cancellation of registration.
16. Exemptions from need for registration.
Exemption from payment of registration fee.
17. Restriction on registration of taxis.
- 17A. Restriction on registration of motor vehicles.

SECTION

- 18. Registration on change of use.
- 19. Transfer of registration.
- 19A. Tax payable on transfer of motor vehicle.
- 19B. Payment of transfer tax.
- 19C. Evidence of sale or date of transfer.
- 19D. Age of motor vehicle.
- 19E. Refund of transfer tax.
- 19F. Exemption.
- 19G. *(Repealed by Act No. 9 of 1997).*
- 20. Interpretation.

PART III

LICENSING OF MOTOR VEHICLES

- 21. Using vehicle without prescribed registration, an offence.
- 22. Licensing Authority may permit goods vehicles to be used for the conveyance of persons.
- 22A. Police and Prison Service vehicles exempted from payment of fees.
- 23. Restrictions on licensing of certain motor vehicles and trailers.
- 24. *(Repealed by Act No. 9 of 1997).*
- 25. Conditions to be satisfied before licence issued.
- 26. Licencing Authority may designate premises.
- 27. Cancellation or refusal of registration.
- 28. Amendment of Register and Certificate of Registration.
- 29.)
- to } *(Repealed by Act No. 9 of 1997).*
- 33.)
- 34. Dealers' general licence.
- 35. Uses of dealers' general licence.
- 36. Register of dealers' general licences.
- 37. Cancellation of dealers' general licence.
- 38. Dealers' general licence not transferable.
- 39. Dealer to accompany vehicle when used.
- 40. Record of vehicles used under authority of dealers' general licence.
Record of hire of rented cars.
- 40A. *(Repealed by Act No. 37 of 1989).*

ARRANGEMENT OF SECTIONS—*Continued*

SECTION

41. International certificates and temporary licences for motor vehicles.

PART IV

DRIVING PERMITS

42. Driving without a permit, an offence.
43. Motorcycles and safety helmets.
- 43A. Private motor cars and certain other vehicles to be fitted with seat belts.
- 43B. Certain motor vehicles to be equipped with seat belts.
- 43C. Wearing of seat belts compulsory.
- 43D. Liability of driver when a child is in front seat.
44. Issue of driving permits.
Fees.
45. Driving instructors.
46. Offences of driving instructor.
47. Driving tests.
48. Physical fitness.
49. Applications for driving permits.
50. Classes of vehicles.
51. Restrictions on driving permits for certain vehicles.
52. Age.
53. Driving test fees.
54. Colour classification of driving permits and provisional permits.
55. International driving permits.
56. Production of driving permit or provisional permit.
- 56A. Exemption in case of valid driving permit held elsewhere.
57. Register of driving permits.
58. Period of driving permit.
59. Expiration of provisional permit.
60. Re-issue of lost or defaced driving permit.
61. Restrictions on the issue of new driving permit after expiration of former one.
- 61A. Charge for expired driving permit.

SECTION

PART V

**DRIVING AND OTHER OFFENCES
AND GENERAL CONDITIONS RELATING
TO THE USE OF ROADS**

- 62. Speed limits.
- 63. Motor racing and speed trials.
- 64. Traffic signs.
- 65. Parking of vehicles and one-way roads.
- 66. Drivers to comply with traffic directions.
- 67. Experimental traffic schemes.
- 68. Temporary prohibition or restriction of traffic on roads.
- 69. Restrictions on parking in certain streets.
- 70. Driving when under influence of liquor.
Disqualification from driving upon conviction.
- 71. Causing death by dangerous driving.
Disqualification from driving upon conviction.
- 71A. Dangerous Driving.
- 71B. Interpretation.
- 72. Careless driving.
- 73. Warning to be given of intended prosecution.
- 74. Taking vehicle without consent of owner.
- 75. Interfering with motor vehicle.
- 76. Restrictions on persons being towed on bicycles.
- 77. Restriction on cyclists riding abreast or holding on to other
moving vehicles.
- 78. Distribution of advertisements from vehicles prohibited.
- 79. Duty to stop, give aid, and report in case of accident.

PART VI

**LEGAL PROCEEDINGS, SUSPENSION AND
CANCELLATION OF DRIVING PERMITS**

- 80. Power to convict for reckless or dangerous driving on trial for
manslaughter.
- 81. Power to proceed on charge for careless driving on hearing of charges
under section 70 or section 71A.

ARRANGEMENT OF SECTIONS—*Continued*

SECTION

- 82. Power of Court to order disqualification from obtaining a driving permit and to cancel permit.
- 83. Right of appeal.
- 84. Production of offender's Record of Conviction.
- 85. Custody of permit while suspended or cancelled.
- 86. Suspended permit to be of no effect.
- 86A. Licensing Authority may suspend driving permit..
- 86B. Permit holder may show cause why driving permit should not be suspended.
- 86C. Surrender and return of driving permit.
- 87. Temporary suspension of permit pending determination of charges.
- 88. Fraudulent application for driving permit.

PART VII

GENERAL

- 89. Fees and duties.
- 89A. *(Repealed by Act No. 9 of 1997).*
- 90. Fraudulent imitation, etc., of documents.
- 91. Offences and general penalty.
- 92. Liability at Common Law.
- 93. Refusing to give name or address or giving false name or address.
- 94. Giving false information.
- 95. Duplicate licences, permits and certificates.
- 96. Liability of driver and person in charge of vehicle for offences.
- 97. Power to require motor vehicles licensed according to M.G.W. to be weighed.
- 98. Recovery of damage to road or bridge.
- 99. Certificate as to damage to be admissible in evidence.
- 100. Regulations.
- 101. *(Repealed by Act No. 25 of 1997).*
- 102. Regulation of conduct of drivers and conductors.
- 103. Regulation of conduct of passengers.
- 104. Control of number of passengers.
- 105. Control of bus terminals and coach stations.

LAWS OF TRINIDAD AND TOBAGO

SECTION

- 106. Offences in connection with Regulations.
- 107. Parking in grounds, etc., of public officers restricted.
- 108. Powers of police where vehicles parked in contravention of Act or left on road.
- 109. Charges payable before delivery of vehicle; and sale of vehicles in custody.
- 110. In the event of a conflict of laws, the provisions of this Act to prevail.
Where similar powers are granted under this and any other law the Board shall decide as to the exercise of those powers.
- 111. Highway Code.

FIRST SCHEDULE.

SECOND SCHEDULE.

THIRD SCHEDULE.

FOURTH SCHEDULE.

FIFTH SCHEDULE.

CHAPTER 48:50

MOTOR VEHICLES AND ROAD TRAFFIC ACT

An Act relating to Motor Vehicles and Road Traffic.

1950 Ed.
Ch. 16 No. 3.
42 of 1934.
Commencement.

[1ST JANUARY 1935]

Short title.

1. This Act may be cited as the Motor Vehicles and Road Traffic Act.

PART I

GENERAL

Interpretation.
[20 of 1953
47 of 1956
35 of 1957
11 of 1963
36 of 1967
3 of 1969
8 of 1978
14 of 1979
8 of 1982
11 of 1988
9 of 1997
25 of 1997
21 of 2000].

2. In this Act—

“agricultural tractor” means a tractor approved by the Licensing Authority exclusively for agricultural purposes;

“agricultural trailer” means a trailer approved by the Licensing Authority exclusively for agricultural purposes;

“approved form” means the form approved under section 4A of the Act;

“Assistant Transport Commissioner”, “Automotive Licensing Officer”, “Motor Vehicles Officer” and “Motor Vehicles Supervisor” mean, respectively, any persons carrying out the provisions of this Act relating to the licensing, registration and examination of vehicles;

“Board” means the Trinidad Transport Board;

“Borough of Arima” means the Borough of Arima as defined in the First Schedule to the Municipal Corporations Act;

Ch. 25:04.

“certificate” means the certificate approved under section 4A of the Act;

“City of Port-of-Spain” means the City of Port-of-Spain as defined in the First Schedule to the Municipal Corporations Act;

“City of San Fernando” means the City of San Fernando as defined in the First Schedule to the Municipal Corporations Act;

- “driver” includes any person actually driving a motor vehicle at any given time and any person in charge thereof for the purpose of driving whenever the same is stationary on any road;
- “driving permit” means a permit issued in accordance with Part IV kept in the form specified in section 54;
- “freight passenger vehicle” means a motor vehicle constructed for the purpose of carrying both passengers and goods and which is approved by the Licensing Authority as suitable for that purpose;
- “goods vehicle” means a motor vehicle other than an agricultural tractor or industrial tractor which is so constructed or adapted as to show its primary purpose is the carriage or haulage of goods, merchandise or other loads, and includes—
- (a) a motor vehicle constructed or adapted for the carriage both of persons and of goods and which is registered for use as a goods vehicle;
 - (b) a motor vehicle which is registered for use as a goods vehicle and which was so registered before 1st January 1963;
- “hiring car” or “taxi” means a public service vehicle having seating accommodation for not more than six passengers and which is of a type approved by the Licensing Authority as suitable for the ordinary purposes of a taxi;
- “indivisible load” means a load which cannot without undue expense or risk of damage be divided into two or more loads for the purpose of conveyance on a road;
- “industrial tractor” means a tractor approved by the Licensing Authority exclusively for industrial purposes;
- “Licensing Authority” means the authority appointed in accordance with the provisions of section 4 for the registration and control of motor vehicles;
- “maximum gross weight” or “M.G.W.” in reference to a goods vehicle means the tare together with the load including the weight of the driver and loaders, and in reference to a motor omnibus means the tare together with the weight of the

driver, conductor and number of passengers for which the vehicle is registered; and for the purposes of this definition the weight of a driver, loader, conductor or passenger shall be taken as 60 kilograms;

“maxi-taxi” means a public service vehicle with seating accommodation for not less than nine nor more than twenty-five passengers;

“motorcycle” means a motor vehicle with less than four wheels and the weight of which unladen does not exceed 365 kilograms;

“motor omnibus” means a public service vehicle other than one registered as a “hiring car” or “maxi-taxi”, and includes a light motor omnibus having seating accommodation for not more than ten passengers, an ordinary motor omnibus having seating accommodation for more than ten passengers and a freight passenger vehicle;

“motor vehicle” means any mechanically propelled vehicle intended or adapted for use on roads and includes a trolley vehicle, but does not include vehicles constructed exclusively for use on rails or other specially prepared tracks;

“motor vehicles tax” means the tax imposed under section 14 of this Act;

“Motor Vehicles Inspector” means any person carrying out the provisions of this Act relating to the inspection and making of reports on the condition of vehicles and includes the person for the time being performing the duties of Automotive Licensing Officer in the Ward of Tobago;

“Municipal Corporation” means a municipal or regional corporation established under the Municipal Corporations Act;

Ch. 25:04.

“overtaking” includes passing or attempting to pass any other vehicle proceeding in the same direction;

“owner”—

- (a) in the case of a motor vehicle that is not registered, includes the person in actual charge or possession of the vehicle in Trinidad and Tobago;

- (b) in the case of a vehicle that is registered, means the person in whose name the vehicle is registered:

Provided that, in the case of a motor vehicle which is the subject of a hire-purchase agreement, it means the person in possession of the vehicle under that agreement; and whenever the registered owner of a motor vehicle is absent from Trinidad and Tobago, the person in actual charge or possession of the vehicle in Trinidad and Tobago shall be deemed to be the owner thereof;

“parking” means causing or permitting a vehicle, whether occupied or not, to stand on a road, except—

- (a) while the vehicle is being loaded or unloaded; or
- (b) while passengers are entering or leaving the vehicle; or
- (c) in compliance with the directions of a constable or of a traffic sign or with the requirements of traffic regulations; or
- (d) while temporarily stopped by reason of traffic conditions; or
- (e) while stopped owing to mechanical breakdown or lack of fuel,

and “park” and other cognate expressions shall be construed accordingly;

“pole trailer” means a trailer so designed that an indivisible load placed thereon will be supported at its front end by the body or chassis of the towing vehicle and at its rear end by the body or chassis of the trailer;

“private motor car” means a motor vehicle approved by the Authority for private use exclusively with seating accommodation for not more than eight persons;

“public service vehicle” means a motor vehicle used for carrying passengers for hire or reward, whether at separate and distinct fares for their respective places or not;

“rented car” means a motor vehicle, other than a motorcycle, of a type approved by the Licensing Authority and having seating accommodation for not more than eight persons including the

driver, which is privately hired from the owner and which is not to be used as a public service vehicle;

“road” means any street, road or open space to which the public are granted access and any bridge over which a road passes, and includes any privately owned street, road or open space to which the public are granted access either generally or conditionally;

“semi-trailer” means any trailer which is so designed that when operated the forward part of its body or chassis rests upon the body or chassis of the towing vehicle;

“tare” means the actual weight of a motor vehicle when unladen but inclusive of the body, accumulators, loose tools, spare wheels and other usual equipment and a full supply of water and fuel used for the purposes of propulsion;

“tonne” means the metric tonne of 1,000 kilograms;

“tractor” means any motor vehicle constructed for the purpose of hauling trailers whether or not it is itself capable of carrying passengers or goods but does not include a goods vehicle so constructed except when such goods vehicle is hauling a trailer;

“traffic” includes bicycles, tricycles, motor vehicles, tramcars, vehicles of every description, pedestrians, and all animals being ridden, driven or led;

“traffic sign” includes any signal (whether an electric automatic signal or otherwise), warning signpost, direction post, sign, line, direction arrow, word, mark or other device erected, placed or otherwise marked on or near a road for the guidance or direction of traffic;

“Traffic Warden” means a person appointed in accordance with the provisions of section 10A;

“trailer” means any vehicle which has no independent motor power of its own and which is attached to a tractor or other motor vehicle, but does not include a side-car attached to a motorcycle;

“Transport Commissioner” means the person mentioned in section 4(1);

“Transport Officer” includes the Transport Commissioner, the Assistant Transport Commissioners, Motor Vehicles Inspectors, Automotive Licensing Officers, Motor Vehicles Officers and Motor Vehicles Supervisors;

“vehicle” includes tramcars, carriages, wagons, carts, motor vehicles, bicycles, tricycles, vans, hand carts, sledges, trucks, barrows and all other machines for the portage of goods or persons.

3. (1) There shall be established a body to be called the Trinidad Transport Board (hereinafter referred to as the Board) consisting of the Chief Technical Officer (Works) as Chairman, the Commissioner of Police or such other First Division Police Officer as may be nominated in writing for the purpose by the Commissioner of Police, the Licensing Authority, the Chairman of the Road Safety Association of Trinidad and Tobago, a member of the Trinidad and Tobago Automobile Association and seven other members to be appointed by the President after consultation with such representatives or bodies, representatives of the following interests, as the President may think fit, that is to say, local government, commerce, industry, agriculture and labour. The President may appoint any person to act in the place of the Chairman or any other member of the Board in the case of his absence or inability to act as such Chairman or other member. The Board may act by any five of their members and may so act notwithstanding any vacancy in the number of members constituting the Board. The Board shall have the power to regulate their procedure.

Trinidad
Transport
Board.
[2 of 1952
11 of 1965
6 of 1974
9 of 1997].

(2) The Board shall act in an advisory capacity and shall advise the President on all matters appertaining to road traffic and in particular as to the following matters:

- (a) licence duties in respect of motor and other vehicles;
- (b) Customs and Excise duties in respect of transport vehicles and fuel therefor;
- (c) the needs of areas as a whole in relation to traffic (including the provision of adequate suitable and efficient services and the elimination of unnecessary or unremunerative services) and the co-ordination of all forms of passenger and goods transport, including transport by rail and sea;
- (d) the regulation and control of traffic;
- (e) the construction and maintenance of roads and the cost thereof; and

LAWS OF TRINIDAD AND TOBAGO

(f) any other matter affecting traffic or transport that the President may refer to the Board.

(3) The Board shall hear and determine any appeal submitted by any aggrieved person against any order or decision of the Licensing Authority or of an Automotive Licensing Officer, and the Board's decision thereon shall be final and conclusive.

(4) The Board shall perform such other duties as are assigned to them by this Act and the Regulations made hereunder or by any Order of the President.

Appointment of Transport Commissioner, Assistant Transport Commissioner, etc. [3 of 1969 9 of 1997 25 of 1997].

4. (1) The Transport Commissioner is the Licensing Authority and shall be charged with responsibility for the registration and inspection of all motor vehicles and issue of driving permits and such other matters as are assigned to him by this Act or any Regulations made thereunder.

(2) Notwithstanding anything to the contrary in this Act, any reference to an Assistant Transport Commissioner, Automotive Licensing Officer, Motor Vehicles Inspector, Motor Vehicles Officer and Motor Vehicles Supervisor is a reference to a Transport Officer and the functions or powers specified in relation to such Officer shall be performed by a Transport Officer.

(3) Transport Officers shall be under the direction of the Transport Commissioner who may assign such officers as may be necessary to such localities and to perform such duties as he directs for the purposes of the Act.

Minister to approve forms, certificates and procedures for registration of vehicles. [25 of 1997].

4A. The Minister shall approve in writing, forms, certificates and procedures required by the Licensing Authority for the registration of all motor vehicles and trailers.

Transport Officers to have powers, etc., of members of the Police Service. [3 of 1969].

5. (1) In the exercise of powers and duties conferred on him by this Act and any Regulations made thereunder, every Transport Officer shall have the powers, authorities and privileges and shall be entitled to all the immunities given by any law from time to time in force to any member of the Police Service.

(2) Where any Transport Officer makes a complaint against any person, any other Transport Officer may appear before the Magistrate who is trying or inquiring into the matter of the said complaint, and shall have the same privilege as to addressing the said Magistrate and as to examining the witnesses adduced in the said matter as the Transport Officer who made the complaint would have had.

6. (1) On the appointment of any person to be a Transport Officer, the Transport Commissioner shall deliver or cause to be delivered to him a precept authorising him to act as such. Precept of appointment. [3 of 1969].

(2) The precept shall be in the following form:

REPUBLIC OF TRINIDAD AND TOBAGO

**THE MOTOR VEHICLES AND ROAD TRAFFIC
ACT (CH. 48:50)**

To
of.....
I,, Transport Commissioner do under and by virtue of the power and authority vested in me by the Motor Vehicles and Road Traffic Act hereby issue to you this precept authorising you to perform the duties of

.....
Transport Commissioner

7. Every Transport Officer shall be provided with a manual describing his powers and duties, a badge and such uniform and other equipment as may be approved by the Minister. Such badge shall be evidence of the office of a Transport Officer and shall in all cases be displayed by every such officer when exercising the duties of his office. The cost of these articles of clothing and equipment shall be defrayed from such funds as may be provided for the purpose by Parliament. Equipment. [3 of 1969].

8. *(Repealed by Act No. 25 of 1997).*

Penalty for assaulting or obstructing Transport Officer. [3 of 1969].

9. Any person who assaults, obstructs or resists any Transport Officer in the execution of his duty, or aids or incites any other person to assault, obstruct or resist any Transport Officer in the execution of his duty, is liable on summary conviction to a fine of three hundred dollars or to imprisonment for six months.

Power to stop and inspect vehicles. [3 of 1969, 25 of 1997].

10. (1) Every driver of a motor vehicle shall, on the request of a Transport Officer in uniform, if such officer shall put up his hand as a signal for that purpose, cause a motor vehicle to stop and remain stationary as long as may be reasonably necessary for the Transport Officer to satisfy himself of the vehicle's roadworthiness and the driver's general compliance with the Act.

(2) Any driver of a motor vehicle who contravenes subsection (1) is liable on summary conviction to a fine of three hundred dollars or to imprisonment for six months.

Appointment and functions of a Traffic Warden. [21 of 2000].

10A. (1) The Police Commissioner may—

- (a) with the approval of the Minister responsible for the Police; and
- (b) subject to—
 - (i) such conditions as the Minister directs; and
 - (ii) criteria as may be established by Order by the Minister responsible for transport after consultation with the Licensing Authority,

appoint by instrument in writing, any member of an organisation or any person as a Traffic Warden for the purpose of assisting the Police in connection with the control and regulation of road traffic and with the enforcement of the law.

(2) A Traffic Warden shall, while in the execution of his duty, wear such uniform as the Police Commissioner, with the approval of the Minister responsible for the Police, directs.

(3) Any driver who—

- (a) fails to comply with the directions given by a Traffic Warden while on duty;
- (b) obstructs a Traffic Warden in the execution of his duty, or aids or incites any other

person not to comply with the directions of a Traffic Warden or to obstruct a Traffic Warden in the execution of his duty,

is guilty of an offence and is liable on summary conviction to a fine of three hundred dollars or to imprisonment for six months.

PART II

REGISTRATION OF MOTOR VEHICLES

11. (1) The Licensing Authority shall cause registers of motor vehicles to be kept in the manner he directs. Motor vehicle registers. [25 of 1997].

(2) The Licensing Authority shall supply to any person applying for a copy of the entries relating to any specified vehicle a copy of these entries on payment of a prescribed fee, provided that he shows that he has a reasonable cause for requiring such a copy.

12. (1) No person shall, in any place, use or keep for use or, being the owner, permit any other person to use or keep for use any motor vehicle— Registration of motor vehicles. [35 of 1957, 44 of 1977, 9 of 1997, 25 of 1997].

- (a) not being a vehicle exempted from registration under this Act, unless it is registered under this Act according to the procedures required by the Licensing Authority or;
- (b) being an agricultural tractor, agricultural trailer or industrial tractor, for any purpose unless the Licensing Authority has granted its approval, in the prescribed manner, of the use of the vehicles for that purpose.

(2) No person shall be liable to a penalty for a breach of this section if he proves that he has taken all reasonable steps to comply with its requirements, and, when the vehicle is in use on a road, that it is on its way for the purpose of being registered.

(3) The Transport Officer to whom application is made shall, upon being satisfied that the provisions of this Act and the Motor Vehicles Insurance (Third-party Risks) Act and Regulations respectively made thereunder, have been complied Ch. 48:51.

with, forthwith enter particulars of the vehicle in the register, and shall assign to the vehicle a registered letter or letters and number, which shall become the identification mark of such vehicle.

(4) A certified copy of the entry in the register shall be given to the owner of the vehicle, and such certificate of registration shall be regarded as *prima facie* evidence that the vehicle to which it refers has been registered.

(5) If a motor vehicle does not bear on it an identification mark as required by the Licensing Authority, this fact shall be regarded as *prima facie* evidence that the vehicle has not been registered, and any constable may detain such a vehicle until enquiries have been made.

(6) The onus of proving that a vehicle has been registered rests upon the owner of the vehicle.

(7) The owner of a motor vehicle shall notify the Licensing Authority of all circumstances or events which affect the accuracy of the entries in the register, at the same time forwarding his certificate of registration for amendment. A Transport Officer may call upon any owner of a motor vehicle at any time to furnish all information for the verification of the entries in the register relating to such vehicle.

(8) Whenever the registered owner of a motor vehicle is about to absent himself from Trinidad and Tobago leaving his registered vehicle in Trinidad and Tobago, he shall notify the Licensing Authority in writing of the name and address of the person in whose charge or possession the vehicle will be left.

(9) No person shall be registered as the owner of a motor vehicle unless he is at least seventeen years of age.

Examination of
motor vehicles.
[3 of 1969
44 of 1977
25 of 1997].

13. (1) Before registering any motor vehicle the Transport Officer shall verify all the particulars in the approved form and may inspect any motor vehicle in accordance with the direction of the Transport Commissioner for the purpose of ensuring that it conforms with the requirements of the Act and the purpose for which it is sought to be registered.

(2) Before registering any goods vehicle, freight passenger vehicle, motor omnibus or trailer, the Transport Officer shall ascertain the maximum gross weight or the maximum number of passengers which the vehicle may be authorised to carry, and such maximum gross weight or maximum number of passengers shall be entered in the register and in the certificate of registration.

(3) If any owner of a motor vehicle or trailer is aggrieved at the outcome of any inspection required under subsection (1) he may appeal to the Licensing Authority who may review the outcome of that inspection and direct that the requirements of the Transport Officer are either unreasonable or that such requirements shall be enforced.

14. (1) There shall be payable to the Board of Inland Revenue in respect of the classes of motor vehicles specified in the Fourth Schedule, a motor vehicles tax computed in accordance with the provisions of that Schedule.

Motor vehicles
tax.
[35 of 1957
28 of 1978
9 of 1997].
Fourth
Schedule.

(2) Motor vehicles tax shall be payable to the Board of Inland Revenue before registration of the motor vehicle.

(3) The President may remit or refund in whole or in part any motor vehicles tax whenever he shall deem it expedient to do so.

(4) If any motor vehicle in respect of which motor vehicles tax is payable is registered contrary to the provisions of this section, such registration shall be void and of no effect and the motor vehicle shall be deemed not to have been registered.

(5) The President may by Order amend the Fourth Schedule.

(6) Every Order made by the President under subsection (5) shall have effect from the date of publication of such Order in the *Gazette* and shall, after four days and within twenty-one days from the date of such publication, be submitted to Parliament, and Parliament may by resolution confirm, amend or revoke such Order.

(7) If an Order is not within the said period of twenty-one days mentioned in subsection (6) submitted to Parliament as provided for in the said subsection (6), such Order shall on the termination of such period expire and be of no further force or effect.

(8) So much of motor vehicles tax as shall have been paid under an Order made under this section as may be in excess of the said tax payable immediately after such Order has been dealt with by Parliament under subsection (6) or has expired under subsection (7) shall be repaid to any person who has paid the same.

Cancellation of registration.
[25 of 1997].

15. (1) The registration of a motor vehicle shall remain valid so long as the vehicle is kept in use and shall only be cancelled where the Licensing Authority is satisfied that—

- (a) the vehicle has been destroyed;
- (b) the vehicle has been rendered permanently unserviceable;
- (c) the vehicle has been permanently removed from Trinidad and Tobago;
- (d) section 23(1) has been contravened; or
- (e) a transaction in respect of the vehicle was effected under a misrepresentation of the information required for the purposes of the transaction.

(2) The owner of a motor vehicle which has been destroyed, rendered permanently unserviceable or has been permanently removed from Trinidad and Tobago shall notify the Licensing Authority, in writing, within one month of such event and an owner who fails to notify the Authority commits an offence.

(3) Prosecution of an offence under subsection (2), may be instituted at any time within two years of the commission of the offence.

(4) Where the Licensing Authority cancels a registration under subsection (1), the Authority shall notify the owner in writing.

(5) Where the owner of a motor vehicle is aggrieved by the decision of the Licensing Authority to cancel his registration, he may appeal to the Board.

16. (1) The following classes of motor vehicles shall be exempted from the need for registration:

- (a) new motor vehicles in the possession of manufacturers or dealers in motor vehicles, but subject to such provisions as to dealers' general licences as may appear hereinafter;
- (b) private motor cars and motor cycles brought into Trinidad and Tobago by visitors for their own use for a period not exceeding three months subject to such conditions as may be prescribed;
- (c) any motor vehicle the property of or used by the President for his official or personal duties.

Exemptions from need for registration. [12 of 1961, 11 of 1965, 44 of 1977, 25 of 1997].

(2) No fee on registration shall be charged in respect of the following:

- (a) any motor vehicle which is the property of the Government or any Municipal Corporation; or the Corporation established under the Public Transport Service Act;
- (b) any motor vehicle specially exempted by an Order of the President on account of its being owned by a public body or of its being used for any charitable, philanthropic or other public purpose:

Exemption from payment of registration fee.

Ch. 48:02.

Provided that the exemption hereby granted from payment of the registration fee in respect of a vehicle shall cease whenever the condition justifying such exemption ceases to apply to that vehicle.

17. (1) Notwithstanding the provisions of section 12, during any period when there is in force an Order under this section, no motor vehicle shall be registered for use as a taxi except in accordance with such Order.

Restriction on registration of taxis. [11 of 1963].

(2) The Minister may by Order prohibit or restrict, subject to such conditions, if any, as may be specified in the Order, the registration of motor vehicles for use as taxis.

(3) In this section, "Minister" means the Minister responsible for road transport.

Restriction on registration of motor vehicles. [8 of 1996 2 of 2002]. First Schedule.

17A. (1) Where a motor vehicle is assembled in Trinidad and Tobago and the Customs duty payable on such a vehicle as assembled has not been paid, the Licensing Authority shall not register the vehicle for use, unless the fee specified in the First Schedule in relation to such a vehicle is paid and the vehicle shall be exempt from motor vehicles tax.

(2) The President may remit or refund the whole or any part of the fee referred to in this section where he considers it expedient to do so.

(3) Notwithstanding subsection (1), with effect from 1st May 2003, no locally assembled motor vehicle using new or used foreign parts shall be registered for use under this Act.

Registration on change of use. [11 of 1963 9 of 1990].

18. (1) Where the owner of a motor vehicle which is registered for use for a particular purpose intends to use that vehicle for some other purpose he shall, before using the vehicle for that other purpose, apply to the Licensing Authority for registration of the vehicle for use for that other purpose; and the application shall, subject to subsection (2), be dealt with as if the vehicle had not previously been registered, but—

- (a) the fee payable for such registration shall be the fee prescribed for an amendment of the Register;
- (b) except as provided by subsection (2), motor vehicles tax shall not be payable before such registration.

(2) Motor vehicles tax shall be payable in accordance with section 14 before the registration of a motor vehicle for a purpose other than that for which it was registered where the vehicle was first registered after 31st December 1962.

(3) Where the tax paid in respect of the current registration is more than that payable for the class of vehicle in respect of which the new registration will apply, no tax is payable.

Transfer of registration. [30 of 1951 3 of 1994 25 of 1997].

19. (1) On the change of possession of a motor vehicle otherwise than by death—

- (a) the motor vehicle shall not be used for more than seven days after such change of possession unless the new owner is registered as the owner thereof;

- (b) the registered owner and the new owner shall, within seven days after such change of possession, make application in writing signed by both of them to the Licensing Authority giving the name and address of the new owner and the date of change of possession and such application shall be accompanied by the certificate of registration and the prescribed fee. The Transport Officer shall thereupon by endorsement of the certificate of registration and entry in the register substitute the name of the new owner for that of the registered owner and shall date and initial the substitution and from such date the new owner shall for all purposes be deemed to be the registered owner of the motor vehicle described in the relevant entry in the register and in such certificate of registration.
- (c) the registered owner and the person seeking registration as the registered owner shall both be present before the Licensing Authority together with the used motor vehicle that is the subject of the transfer at the time that transfer of registration occurs;
- (d) where a person referred to in paragraph (c) is a company, a letter of authorisation signed by a director of the company authorising a representative to act on behalf of the company shall be produced to the Licensing Authority;
- (e) where a person referred to in paragraph (c) is unable to be present due to illness or disability, the Licensing Authority or an officer appointed by him, upon payment of a fee of one hundred dollars to be paid by or on behalf of the ill or disabled person, shall be required to visit the person and the vehicle for the purpose of effecting the transfer of registration;

(f) where a person referred to in paragraph (c) is out of the country, the Licensing Authority may effect the transfer of registration if the other person produces a sworn affidavit to the effect that that other person is out of the country.

(2) In the case of the death of the registered owner the legal personal representative of the deceased in Trinidad and Tobago shall be deemed to be the owner for the purposes of such transfer, and in the absence of any legal personal representative in Trinidad and Tobago the person into whose possession the motor vehicle shall lawfully come shall, for the purposes of such transfer, be deemed to be the registered owner: Provided that such personal representative or other person as aforesaid shall notify the Licensing Authority of the death of the registered owner within one month of the happening of such event.

(3) At the discretion of the Transport Officer a new certificate of registration may be issued instead of endorsing the original certificate.

(4) If the Licensing Authority is satisfied that there has been a change of possession of a motor vehicle but that the registered owner has failed to make the application referred to in subsection (1)(b) or to surrender the certificate of registration, the Licensing Authority may, without prejudice to any proceedings which may be taken against the registered owner for such failure, transfer the registration of the motor vehicle in the same manner as if the provisions of the said subsection (1)(b) had been complied with.

(5) Where a registration of transfer of a used motor vehicle has not been made within seven days after the change of possession of that vehicle in accordance with subsection (1)(a), the registered owner shall be liable to pay to the Licensing Authority a penalty of two hundred dollars.

(6) Where a registration of transfer referred to in subsection (5) has not been made within fourteen days after the change of possession of that vehicle, the registered owner is guilty of an offence and is liable upon summary conviction to a fine of five thousand dollars and imprisonment for six months.

19A. (1) There shall be charged, levied and collected in respect of every used motor vehicle in respect of which there is to be a transfer of registration on the change of possession a tax (hereinafter called “transfer tax”) as specified in the Fifth Schedule.

Tax payable on transfer of motor vehicle. [3 of 1994].

Fifth Schedule.

(2) The Tax Authority shall be the Board of Inland Revenue which, in respect of the collection and recovery of transfer tax, has all the powers that it has in relation to income tax under the Income Tax Act.

Ch. 75:01.

19B. (1) The transfer tax shall be paid to the Licensing Authority by the person seeking registration as the registered owner (hereinafter referred to as “the transferee”) at the time of the registration of the change of possession of the motor vehicle.

Payment of transfer tax. [3 of 1994].

(2) A transferee shall not be registered as the new owner in respect of the transfer of a used motor vehicle unless the transfer tax is paid.

(3) Subject to subsection (4), the transfer tax shall not be payable by used car dealers registered under the Value Added Tax Act.

Ch. 75:06.

(4) In order to be eligible for an exemption from the payment of the transfer tax, a used car dealer shall register with the Licensing Authority as an exempt person and shall—

(a) produce a Value Added Tax Certificate to the Licensing Authority; and

(b) satisfy the Licensing Authority that—

(i) he is a *bona fide* dealer in used motor vehicles; and

(ii) he has sold five or more used motor vehicles in the period of twelve months preceding the time of the aforementioned registration.

(5) A person shall not be considered a *bona fide* dealer in used motor vehicles unless he is engaged in the business of buying used motor vehicles for resale.

(6) Where a person purchases a used motor vehicle from a person registered under the Value Added Tax Act, he shall be

exempt from the payment of the transfer tax where he produces to the Licensing Authority a tax invoice under that Act in respect of the purchase.

Evidence of sale or date of transfer. [3 of 1994].

19C. (1) Where a transfer of registration on the change of possession of a used motor vehicle is as a result of the sale of that vehicle, the purchaser shall produce to the Licensing Authority at the time of registration of the change of possession of the vehicle a receipt evidencing such sale.

(2) Where there is a transfer of registration on the change of possession of a used vehicle without the payment of consideration, there shall be produced to the satisfaction of the Licensing Authority at the time of registration of the change of possession of the vehicle evidence of the date of transfer of ownership of the vehicle.

Age of motor vehicle. [3 of 1994].

19D. For the purposes of the transfer tax, the age of the motor vehicle shall be determined from the date of first registration of that vehicle.

Refund of transfer tax. [3 of 1994].

19E. The President may remit or refund in whole or in part any transfer tax whenever he deems it expedient to do so.

Exemption. [3 of 1994].
Ch. 75:02.

19F. Unconditional gifts of motor vehicles to an organisation approved by the President under section 6(1)(g) of the Corporation Tax Act are exempt from the transfer tax.

19G. (*Repealed by Act No. 9 of 1997*).

Interpretation. [44 of 1977].

20. In this Part the expression “motor vehicle” includes trailer.

PART III

LICENSING OF MOTOR VEHICLES

(*This Heading was deleted by section 5 (h) of Act No. 9 of 1997*)

Using vehicle without prescribed registration, an offence. [11 of 1963
14 of 1979
3 of 1994
9 of 1997].

21. (1) Save as is otherwise provided in this Act, if—
(a) (*Deleted by Act No. 9 of 1997*);
(b) any motor vehicle or trailer is used upon any road for a purpose which is not authorised by the registration issued in respect thereof or in contravention of any provisions of this Act; or

- (c) any goods vehicle, public service vehicle, rented car or trailer is used upon a road being loaded so as to exceed the maximum gross weight or the number of passengers, respectively, covered by the registration,

the owner or the driver or other person in charge of the motor vehicle, as the case may be, who contravenes—

- (i) *(Deleted by Act No. 9 of 1997)*;
- (ii) paragraph (b) or (c), is liable to a fine of four hundred dollars.

(2) Where the driver of any vehicle is charged with an offence under subsection (1), the Magistrate may order that a summons be issued against any person alleged by the driver to be the owner of the vehicle, making such alleged owner the co-defendant in the case; and the Magistrate may, after hearing the evidence and witnesses of all parties, make such order in regard to the payment of any penalty and costs as to the Magistrate seems just.

- (3) } *(Repealed by Act No. 9 of 1997).*
- (4) }

(5) No motor vehicle shall be used as a taxi which is not duly registered as such under this Act; and if this subsection is contravened, the owner and the driver of the motor vehicle shall be guilty of an offence against this Act; but it shall be a defence on the part of the owner to prove that the contravention was without his knowledge and that he had taken all reasonable steps to avoid such contravention.

- (6) } *(Repealed by Act No. 9 of 1997).*
- to }
- (8) }

22. (1) Notwithstanding anything contained in section 21 the Licensing Authority may, in his discretion and on payment of the appropriate fee (if any) specified in the First Schedule, grant permission to enable a goods vehicle, agricultural trailer or trailer to be used for the conveyance, either generally or on particular

Licensing Authority may permit goods vehicles to be used for the conveyance of persons. [9 of 1997]. First Schedule.

journeys, of such number and classes of passengers, without hire or reward, and of such number of other persons employed for the purpose of loading or unloading the goods, merchandise or other loads carried on the goods vehicle, agricultural trailer or trailer as he may think fit, subject to such conditions as he may impose.

(2) Whenever permission is granted under the authority of subsection (1), a permit under the hand of the Licensing Authority in a form to be determined by him and containing the conditions subject to which such permission has been granted shall be issued to the registered owner of the goods vehicle, agricultural trailer or trailer, as the case may be.

(3) No such permit for the conveyance of passengers shall be valid for a longer period than six months from the date of issue thereof and no such permit for the conveyance of persons employed to load and unload goods, merchandise or other loads shall be valid for a longer period than the unexpired portion of the calendar year in which the permit was issued.

(4) The Licensing Authority may waive the payment of any fee in the case of any agricultural trailer used for agricultural purposes or of any vehicle registered as a goods vehicle but not primarily constructed for the carriage or haulage of goods, merchandise or other loads.

(5) The Licensing Authority may cancel or suspend any permit issued under this section if in his opinion any of the conditions attached to the issue of such permit have not been complied with by the registered owner.

First Schedule.

(6) The Licensing Authority may issue a duplicate permit on payment of the appropriate fee specified in the First Schedule in place of any permit proved to his satisfaction to have been lost, defaced, mutilated or rendered illegible.

Police and
Prison Service
vehicles
exempted from
payment of fees.
[17 of 1986
9 of 1997].

22A. (1) Notwithstanding anything contained in sections 21 and 22, the Licensing Authority without charging a fee, may, in such form as he may determine, grant permission to the Police or Prison Service for vehicles belonging to those Services and registered as goods vehicles, to convey their personnel and persons in custody of the Police and Prison authorities.

(2) Notwithstanding the provisions of this Act station wagons or estate cars however registered may be used for the purpose of carrying passengers.

(3) Section 22(1) shall not apply to—

- (a) Police and Prison Service vehicles;
- (b) station wagons and estate cars however registered.

23. (1) Save as provided in this section—

- (a) no motor vehicle exceeding the maximum gross weight of fifteen tonnes;
- (b) no trailer exceeding the maximum gross weight of eight tonnes;
- (c) no motor vehicle or trailer all the wheels of which are not fitted with pneumatic tyres;
- (d) no motor vehicle the windscreen or any other window of which is fitted with glass so tinted, treated or darkened as to obscure the view of the inside of the vehicle from the outside;
- (e) no motor vehicle painted in the colour or combination of colours used by the Trinidad and Tobago Regiment, the Coast Guard, the Police Service or the Prison Service other than a motor vehicle of the Trinidad and Tobago Regiment, the Coast Guard, the Police Service, or the Prison Service respectively, and no motor vehicle, other than, a motor car, painted in the colour or combination of colours used by the Fire Service,

Restrictions on licensing of certain motor vehicles and trailers. [31 of 1976 17 of 1978 9 of 1997].

shall be used upon any road.

(1A) The Licensing Authority shall cancel the registration of any vehicle or trailer referred to in subsection (1) where, in relation to that vehicle or trailer, subsection (1) is contravened.

(2) The Licensing Authority may, on the recommendation of the Board and with the approval of the Chief Technical Officer (Works), by Notification published in the *Gazette* authorise the use on roads, subject to such restrictions and conditions as may be

specified in the Notification, of special types of motor vehicles or trailers which are constructed for special purposes or do not comply with this section or Regulations made under section 100; but nothing contained in this subsection shall be deemed to prohibit any authority responsible for the maintenance of any road or other person from recovering any extraordinary expense incurred in respect of any such road by reason of such use.

(3) The Chief Technical Officer (Works) may grant a special permit to the owner of a tractor, goods vehicle or trailer for conveying an indivisible load of heavy machinery or other articles in excess of the maximum gross weight of fifteen tonnes in the case of a motor vehicle and of eight tonnes in the case of a trailer, subject to such conditions as may be specified in the permit and on payment of a special fee calculated at the rate of eight cents per kilometre or part thereof to be travelled for each tonne or part thereof of the gross weight to be transported in excess of the maximum gross weight for which such tractor, goods vehicle or trailer is registered.

(4) The Chief Technical Officer (Works) may grant a special permit to the owner of any machine used for industrial purposes to enable such machine to be moved from one place to another, subject to such conditions as may be specified in the permit, and on payment of a special fee calculated at the rate of four cents per kilometre or part thereof to be travelled for each tonne or part thereof of the gross weight to be transported; but the Chief Technical Officer (Works) may reduce by not more than fifty per cent the special fee payable under this subsection when the permit is granted in respect of a machine which is fitted entirely with pneumatic tyres.

(5) Notwithstanding the issue of a permit under subsection (3) or (4), no fee shall be payable in respect of road rollers, nor in respect of motor vehicles using only roads which are not maintained at the public expense, nor in any case in which the distance travelled along a public road does not exceed eight hundred metres.

(6) Any person to whom a permit has been granted under this section who fails to observe any of the conditions specified in such permit is liable to a fine of four hundred dollars, and, in addition, he shall be liable for any damages occasioned by his neglect or failure to observe any of such conditions.

24. }
25. (1) } *(Repealed by Act No. 9 of 1997).*

Conditions to be satisfied before licence issued. [9 of 1997].

(2) The decision of the Licensing Authority as regards the class or type to which any vehicle conforms or under which it should be registered, shall be conclusive.

26. (1) For the purpose of the inspection of motor vehicles or trailers for roadworthiness, the Licensing Authority may designate premises not being under the control of the Authority where such vehicles may be examined by persons not in the employ of the Authority and further the Authority may authorise such persons to issue the approved certificate.

Licensing Authority may designate premises. [25 of 1997].

(2) A designation may be subject to such conditions as may be determined by the Licensing Authority.

(3) A current list of designated premises shall be published in the *Gazette* and at least one daily circulating newspaper.

27. (1) Where a Transport Officer certifies in writing that the motor vehicle or trailer is so constructed or is in such a condition as to constitute a health, safety or environmental hazard to any person travelling in the vehicle or to other members of the public or is injurious to the roads or contravenes the Act, the Licensing Authority may cancel a motor vehicle registration or trailer registration or refuse to renew such registration.

Cancellation or refusal of registration. [25 of 1997].

(2) An owner of a motor vehicle or trailer in respect of which the registration is cancelled or for which the issue or renewal of the registration is refused may appeal to the Transport Board.

28. On transfer of ownership of a motor vehicle or trailer, the Transport Officer shall, on payment of the prescribed fee, duly amend the register and the certificate of registration.

Amendment of Register and Certificate of Registration. [25 of 1997].

29. }
to } *(Repealed by Act No. 9 of 1997).*
33. }

Dealers' general licence. [25 of 1997].

34. A Transport Officer may issue to a dealer in, manufacturer or repairer of, motor vehicles or trailers, who makes application in the approved form, a dealers' general licence which, subject to the provisions of sections 35 to 40 and to any other conditions for the purposes of the Act, shall authorise the use of any number of motor vehicles or trailers the property of the dealer.

Uses of dealers' general licence. [25 of 1997].

35. A dealers' general licence in the approved form shall authorise the use of any motor vehicle or trailer, the property of the dealer, which is being tested by the dealer, or is being tested or used for the purpose of effecting a sale. It shall not authorise the carriage of passengers or goods for fee or reward, or any passenger not engaged in testing the vehicle or inspecting the vehicle with a view to purchase.

Register of dealers' general licences. [25 of 1997].

36. Motor vehicles and trailers used under the authority of a dealers' general licence shall not be registered in the manner provided by section 12 but the Transport Officer shall keep a separate register in the approved form of all such licences issued by him.

Cancellation of dealers' general licence. [25 of 1997].

37. (1) A Transport Officer may at any time cancel a dealers' general licence for a breach of any of the provisions of this Act or of any Regulations made thereunder.

(2) The Transport Officer shall give notice of such cancellation to the person to whom such licence was issued, and may at his discretion repay to him so much of the annual fee paid as is proportionate to the unexpired portion of the year in respect of which the fee was paid.

(3) Any person whose licence has been cancelled in accordance with this section or to whom a dealers' general licence has been refused may appeal to the Licensing Authority against

the decision of the Transport Officer, and the Licensing Authority may order that the cancellation shall be confirmed or that the licence be restored to the holder.

38. No dealers' licence shall be used for any purpose not provided for in this Act nor shall it be transferred or assigned to any other person without the authority of the Transport Officer.

Dealers' general licence not transferable. [25 of 1997].

39. No motor vehicle or trailer shall be used on any road under the authority of a dealers' general licence unless the holder of the licence, or a person duly authorised by him in writing, accompanies such vehicle.

Dealer to accompany vehicle when used.

40. (1) The holder of a dealers' general licence shall keep in the approved form, a record of every occasion on which a motor vehicle or trailer is used under the authority of such licence. He shall produce such record for inspection when requested by any First Division Police Officer or by any police officer authorised in writing by any First Division Police Officer.

Record of vehicles used under authority of dealers' general licence. [36 of 1967 25 of 1997].

(2) The owner of a rented car or a rented motor cycle shall keep in the prescribed form a record of every occasion on which a rented car or a rented motor cycle is hired out. He shall produce such record for inspection when requested by any First Division Police Officer or Transport Officer or any police officer authorised in writing by any First Division Police Officer, or by any Transport Officer.

Record of hire of rented cars.

40A. *(Repealed by Act No. 37 of 1989).*

41. (1) The owner of any motor vehicle in respect of which an international certificate for a motor vehicle has been issued elsewhere than in Trinidad and Tobago, in accordance with the provisions of any International Convention relating to the international circulation of motor vehicles which has been applied to Trinidad and Tobago, shall, whilst such certificate remains valid and subject to such conditions as the Licensing Authority determines, be exempted from any requirement to register such motor vehicle.

International certificates and temporary licences for motor vehicles. [9 of 1997 25 of 1997].

LAWS OF TRINIDAD AND TOBAGO

(2) Where a motor vehicle is brought into Trinidad and Tobago for the purpose of being used by the owner during a visit, and the owner of such motor vehicle does not hold an international certificate as aforesaid, the Licensing Authority may issue a temporary licence to use the motor vehicle without registration or payment of any fee for not more than three months and subject to such conditions as the Licensing Authority determines.

Ch. 48:51.

(3) No motor vehicle in respect of which an international certificate or temporary licence has been issued shall be used in Trinidad and Tobago for hire or trade purposes unless the owner has complied with the provisions of the Motor Vehicles Insurance (Third-party Risks) Act.

(4) Where a person in Trinidad and Tobago desires to use a motor vehicle in any other country which has adhered to any International Convention as aforesaid, he shall apply to the Licensing Authority for an international certificate in respect of the motor vehicle.

(5) The Licensing Authority shall have power, subject to such conditions as may from time to time be prescribed, to issue international certificates for motor vehicles in accordance with any International Convention as aforesaid. Before the certificate is issued, the applicant must satisfy the Licensing Authority that the motor vehicle complies with the requirements of the said Convention, and for such purpose the Licensing Authority may require an examining Inspector to examine the motor vehicle and report thereon.

(6) The Licensing Authority shall keep a record of all international certificates for motor vehicles and temporary licences issued by him, and of all motor vehicles being used in Trinidad and Tobago under the authority of international certificates issued in other countries.

PART IV

DRIVING PERMITS

Driving without a permit an offence. [12 of 1961 19 of 1978 *14 of 1979 25 of 1997].

42. (1) Save as in this section provided, no person shall drive a motor vehicle on a road unless he is the holder of a valid driving permit for a motor vehicle of that class, and no person shall employ

*See last page of this Act for transitional provisions relating to permits.

any person to drive a motor vehicle on a road unless the person so employed is the holder of a valid driving permit for a motor vehicle of that class, and if any person acts in contravention of this provision, he shall be liable to a fine of five hundred dollars or imprisonment for six months: Provided that if the driver of the vehicle has never been the holder of a valid driving permit or has been previously refused a valid driving permit or is disqualified from holding or obtaining a valid driving permit, he may be arrested forthwith without a warrant and he shall be liable to a fine of one thousand dollars or imprisonment for one year.

(2) Notwithstanding subsection (1), for the purpose of learning to drive a motor vehicle of any class, a person (in this section referred to as “a learner”) who is not the holder of a valid driving permit for a vehicle of that class may nonetheless drive a vehicle of such a class on a road, so long as he is the holder of a provisional permit issued for that class of motor vehicle by the Transport Officer.

(3) A learner who fails to comply with any condition attaching to or any restriction specified in his provisional permit is liable on conviction to the penalty prescribed in subsection (1) as if he were not the holder of a provisional permit and upon conviction the provisional permit shall be cancelled.

(4) When granting a provisional permit for the purpose mentioned in subsection (2), the Transport Officer may impose such conditions and restrictions as he may deem necessary for the safety of the public and shall, without prejudice to the generality of the foregoing words, specify—

- (a) that the learner shall drive upon such roads and at such times as may be mentioned in the permit;
- (b) that the learner shall not use a taxi, or a motor omnibus carrying passengers, for the purpose of learning to drive; and
- (c) that when learning to drive a motor vehicle (other than a motorcycle) the learner shall have sitting next to him, for the purpose of instructing him, a person who is the holder of a valid driving permit

for the class of vehicle that the learner is learning to drive and has been the holder of such a permit for the requisite period as specified in section 45:

Provided that a learner may appeal to the Board against the refusal of a Transport Officer to grant him a learner's permit or against any condition or restriction imposed by the Transport Officer and, on such appeal being made, the Board may make such order as they think just, and such order shall be final and conclusive.

(5) A provisional permit shall not be issued in respect of a motor vehicle in Class 4, 5, 6 or 7 unless the learner already holds a driving permit in respect of a motor vehicle in the next lower Class and has held such a permit for a period of not less than twelve months.

(6) A learner and the person accompanying him for the purpose of instruction, shall each be liable for any offence committed against any of the provisions of this Act during the course of such instruction.

(7) It shall be lawful for any person subject to the orders of the Military Authority to drive a motor vehicle owned or hired by the Military Authority whilst such vehicle is being used for military purposes so long as he is the holder of an identification card in a form approved by the Licensing Authority and signed by the Commander of the Trinidad and Tobago Defence Force or by a military officer authorised by him in that behalf, provided that such person is not disqualified by law from holding a driving permit under this Act and is on duty and is driving a vehicle of the class specified in the identification card.

Motorcycles and safety helmets. [20 of 1978].

43. (1) Notwithstanding section 42, from 1st September 1978 no person may drive or be carried on a motorcycle on any road unless he wears a safety helmet capable of affording the head of the wearer protection from injury in the event of an accident.

(2) A person who contravenes subsection (1) is liable on summary conviction to a fine of five hundred dollars or imprisonment for six months.

(3) The types of helmet which are capable of affording the head of the wearer protection from injury in the event of an accident shall be prescribed by the Minister, by reference to design, construction or other quality, by Notification.

***43A.** (1) Every—

- (a) private motor car,
- (b) public service vehicle, and
- (c) goods vehicle,

Private motor cars and certain other vehicles to be fitted with seat belts. [17 of 1986 226/1994 25 of 1997].

not exceeding a maximum tare weight of 3,000 kilograms, subject to such exemptions as may be prescribed, brought into, or assembled in Trinidad and Tobago shall, before such motor vehicle is registered, be fitted with a seat belt for the driver and for every passenger who may occupy a front seat of such vehicle and such seat belt shall form an integral and not an optional part of the vehicle.

(2) The seat belt referred to in subsection (1), shall be so designed as to provide restraint for both upper and lower parts of the trunk of the wearer and shall be of the type prescribed—

- (a) by reference to design, construction or other quality;
- (b) by reference to different classes of vehicles, different descriptions of persons and different circumstances, save that in a motor vehicle authorised to carry two passengers in the front the seat belt affixed to the middle front seat need not provide restraint for the upper part of the trunk of the wearer.

(3) The Licensing Authority shall, before the registration of any motor vehicle referred to in subsection (1), satisfy himself that the provisions of that subsection and of any Regulation made in pursuance of subsection (2) have been complied with and may refuse to register any motor vehicle which in his opinion fails to satisfy all or any of those requirements.

*Date of commencement of sections 43A, 43B, 43C and 43D — 1st January 1995 (LN 226/1994).

LAWS OF TRINIDAD AND TOBAGO

(4) The Minister may make Regulations for the purposes of subsection (2).

Certain motor vehicles to be equipped with seat belts. [17 of 1986].

43B. (1) Every person who is the registered owner of any motor vehicle referred to in subsection (1) of section 43A shall have such motor vehicle fitted with seat belts of the type referred to in subsection (2) of section 43A.

(2) The registered owner of a motor vehicle referred to in subsection (1) who contravenes the provisions of that subsection is guilty of an offence and liable on summary conviction for a first offence to a fine of one thousand dollars and on any subsequent conviction to a fine of two thousand dollars.

Wearing of seat belts compulsory. [17 of 1986].

43C. (1) The driver and every passenger sixteen years of age or more occupying a front seat in any motor vehicle referred to in subsection (1) of section 43A shall wear a seat belt while the motor vehicle is in motion.

(2) Any person who contravenes the provisions of subsection (1) is guilty of an offence and liable on summary conviction to a fine of five hundred dollars.

(3) A person shall not be convicted under this section if he proves that at the material time he held a valid certificate signed by a legally qualified medical practitioner to the effect that it is inadvisable on medical grounds for him to wear a seat belt.

(4) The Minister may make Regulations exempting persons from the provisions of subsection (1).

Liability of driver when a child is in front seat. [17 of 1986].

43D. (1) The driver of a motor vehicle referred to in subsection (1) of section 43A shall not without reasonable excuse drive such motor vehicle while there is in the front seat of the motor vehicle a child of more than two years and less than sixteen years of age who is not wearing a seat belt.

(2) The driver of a motor vehicle who contravenes the provisions of subsection (1) is guilty of an offence and liable on summary conviction to a fine of five hundred dollars.

(3) The driver of a motor vehicle shall not be guilty of an offence under this section if he proves that the child not wearing a seat belt held a valid certificate signed by a medical practitioner to the effect that it is inadvisable on medical grounds for the child to wear a seat belt.

44. (1) Driving permits shall be issued by a Transport Officer to applicants in accordance with this Part. Issue of driving permits. [25 of 1997].

(2) On the issue of a driving permit there shall be payable such fee as may from time to time be prescribed. Fees.

45. (1) A person who instructs a learner to drive a motor vehicle in Class 2, 3, 4 or 7 shall be the holder of a valid driving permit for that class of vehicle for a period of not less than three years. Driving instructors. [14 of 1979 25 of 1997].

(2) A person who instructs a learner to drive a motor vehicle in Class 5 or 6 shall be the holder of a valid driving permit for that class of vehicle for a period of not less than five years.

(3) A person who instructs a learner shall have with him at all times while in a vehicle instructing the learner, his valid driving permit in respect of the class of vehicle in which he is giving instruction.

46. (1) A person who instructs a learner and who— Offences of driving instructor. [14 of 1979 25 of 1997].

- (a) is not the holder of a valid driving permit for the class of motor vehicle in which he is giving instruction; or
- (b) is not the holder of a permit referred to in paragraph (a) for the period specified in section 45; or
- (c) is giving instruction to a learner who is driving a motor vehicle on a road and the learner is not the holder of a provisional permit for that class of vehicle,

is liable on conviction to a fine of one thousand dollars.

(2) Upon conviction under this section, the Court may disqualify the offender from driving for a period not exceeding one year.

Driving tests.
[25 of 1997].

47. (1) A Transport Officer in his discretion may require an applicant for a valid driving permit to produce a certificate of having passed a driving test signed by such association as may be approved of by the Licensing Authority.

(2) Driving tests may be conducted by such examiners as the Licensing Authority shall from time to time approve or appoint for the purpose.

(3) The nature of the driving test shall be at the discretion of the Transport Officer or of such examiner as aforesaid but shall include a test of the applicant's knowledge of the rules of the road, road signals and road signs; but where the applicant desires permission to drive an agricultural tractor only such test shall be restricted to the driving of an agricultural tractor and to questions affecting such driving and shall not include questions affecting the driving of motor vehicles generally.

(4) If the applicant requires permission to drive a particular class of vehicle only or if the applicant is being tested under the provisions of section 48(2), then the examiner shall issue a certificate on which any appropriate restrictions are clearly set forth, after satisfying himself by means of such tests as he may deem suitable that the applicant is qualified to drive a vehicle of such particular class or of such particular construction. In such cases, the Transport Officer shall clearly set forth the restrictions on the permit itself.

Physical fitness.
[20 of 1978
14 of 1979
25 of 1997].

48. (1) The Transport Officer shall not issue a driving permit to any person unless he has personally satisfied himself that the vision, hearing and bodily and mental fitness of the applicant are such as to warrant the issue of a driving permit and that the applicant is of good character.

(2) If a permit is refused under subsection (1) other than on the grounds as to character, the applicant may claim to be

subjected to a test as to his fitness or ability to drive a motor vehicle, or a motor vehicle of a particular class or description, or a motor vehicle of a particular form of construction, and if he passes such test and is not otherwise disqualified the permit shall not be refused by reason of the provisions of subsection (1).

(3) An applicant for the issue or renewal of a driving permit to drive a motor vehicle other than a motorcycle or a private motor car or an applicant for the issue or renewal of a driving permit who has attained the age of sixty-five years shall submit together with his application a medical certificate that his vision, hearing and bodily and mental fitness are such as to warrant the issue of a driving permit of the kind to which the application relates.

(4) Where the holder of a driving permit or provisional permit suffers the loss of use of an eye or limb, his permit is revoked and shall be returned to the Licensing Authority within three months of his suffering the disability.

(5) A person referred to in subsection (1) who notwithstanding his disability wishes to drive may claim to be subjected to a test as to his fitness to drive as is contemplated by subsection (1).

(6) A person who passes a test under this section shall be issued a driving permit or provisional permit, as the case may be, subject to such terms and conditions as the Transport Officer may impose, and a permit so issued may be for a period of one year.

(7) Where a person who is the holder of a driving permit or provisional permit is advised by a registered medical practitioner that he is unfit to drive by reason of some physical or mental incapacity, his permit is revoked and shall be returned forthwith to the Licensing Authority.

(8) Where the person referred to in subsection (7) wishes to resume driving upon the cesser of his incapacity, he may, having regard to the duration of his incapacity, be required by the Transport Officer to be subjected to a driving test.

(9) A person who fails to comply with the requirements of this section relating to the return of his driving permit is guilty

of an offence and liable on conviction to a fine of one hundred dollars and to a further fine of five dollars for each day the offence continues after conviction thereof.

Applications for driving permits. [25 of 1997].

49. Applications for driving permits shall be made to the Transport Officer on the approved form and shall be signed by the applicant.

Classes of vehicles. [14 of 1979, 8 of 1982, 6 of 1992, 25 of 1997].

50. For the purposes of this Part, there shall be the following classes of motor vehicles:

- Class 1 Motorcycles
- Class 2 Wheel tractors
- Class 3 Light motor vehicles (including private motor cars, taxis with a tare weight not exceeding 2270 kilogrammes, maxi-taxis whatever their tare weight and light goods vehicles not exceeding a maximum gross weight of 2950 kilograms)
- Class 4 Heavy motor vehicles (including motor vehicles whose maximum gross weight exceeds 2950 kilogrammes but does not exceed 15240 kilogrammes)
- Class 5 Extra heavy motor vehicles (including motor vehicles whose maximum gross weight exceeds 15000 kilogrammes)
- Class 6 Motor omnibuses
- Class 7 Motor vehicles not specified in Classes 1 to 6.

Restrictions on driving permits for certain vehicles.

51. (1) Subject to subsection (2), no driving permit shall be issued or endorsed as valid for a public service vehicle or for a goods vehicle exceeding the maximum gross weight of 2540 kilogrammes to an applicant who is under the age of twenty-one years nor for any such goods vehicle or for a public service vehicle unless the applicant has driven a motor vehicle other than a motorcycle regularly during the preceding twelve months.

(2) The driving permit of an applicant who has previously held a driving permit endorsed as valid for a goods vehicle or public service vehicle may, in the discretion of the Licensing Authority and subject to such conditions or tests as he may think fit to impose,

be endorsed as valid for a goods vehicle or public service vehicle, as the case may be, notwithstanding that the applicant has not driven a motor vehicle other than a motorcycle regularly during the preceding twelve months.

52. Save as provided in section 51 any person not being under the age of seventeen years and not being otherwise disqualified shall be qualified to obtain a driving permit. Age.

53. Every person undergoing a driving test under section 47 shall pay in respect of such test and certificate of competency such fee as may from time to time be prescribed. The fee for examination shall be paid irrespective of what the result of the test may be. If the examiner is a Government Officer, the fee for examination shall be credited to the public revenue, and if the examiner is not a Government Officer, the fee shall be appropriated to the examiner. The fee for the certificate of competency shall be appropriated to the association. Driving test fees.

54. Driving permits and provisional permits shall be in the approved form. Driving permits shall be classified by a colour indication to correspond with the class of vehicle in respect of which they are issued, as follows: Colour classification of driving permits and provisional permits. [8 of 1978, 14 of 1979, 25 of 1997].

- Class 1 Brown
- Class 2 White
- Class 3 Red
- Class 4 Yellow
- Class 5 Orange
- Class 6 Blue
- Class 7 Pink.

Provisional permits shall be colour classified, Green.

55. (1) The holder of an international driving permit issued elsewhere than in Trinidad and Tobago, in accordance with the provisions of any International Convention relating to the international circulation of motor vehicles which shall have been applied to Trinidad and Tobago, shall, whilst such permit remains International driving permits. [25 of 1997].

valid, be exempted from any requirement to hold a driving permit under this Act to drive in Trinidad and Tobago; but he shall only be entitled to drive in Trinidad and Tobago a motor vehicle of the class for which he holds an authorisation to drive in the country in which his international driving permit was issued.

(2) Where a person in Trinidad and Tobago desires to drive a motor vehicle in any other country which shall have adhered to any International Convention as aforesaid, he shall apply to the Licensing Authority for an international driving permit. The applicant must comply with the requirements of the said Convention and shall, in addition to such other particulars as may be required by the Licensing Authority, satisfy the latter that he holds a valid driving permit issued in Trinidad and Tobago and that he is ordinarily resident in Trinidad and Tobago. The Licensing Authority shall have power to issue international driving permits in accordance with any International Convention as aforesaid and on payment of the prescribed fee. Such permits shall, unless suspended by a Court, remain in effect for twelve months from the date of issue.

(3) The Licensing Authority shall keep a register of all holders in Trinidad and Tobago of valid international driving permits issued elsewhere than in Trinidad and Tobago, and of all holders of international driving permits issued by him.

Production of
driving permit
or provisional
permit.
[8 of 1978
21 of 1978
14 of 1979
25 of 1997].

56. (1) A person who drives or is in charge of a motor vehicle on any road or a learner who is in a motor vehicle on any road receiving instruction shall have on his person or in the motor vehicle for production as required by subsection (2) his driving permit or provisional permit as the case may be.

(2) A Transport Officer in uniform or a police officer in uniform may require any person referred to in subsection (1) to produce his driving permit or provisional permit for examination, in order to ascertain the name and address of the holder of the permit, the date of issue and the Transport Officer by whom it was issued.

(3) A person who fails to comply with the requirements of this section is liable on conviction to a fine of five hundred dollars.

56A. (1) Notwithstanding section 42(1) the holder of a valid driving permit issued in any country referred to in subsection (2) shall, whilst such permit remains valid, be exempted for a period of three months from the date of his arrival in Trinidad and Tobago from any requirement to hold a driving permit issued under this Act to drive in Trinidad and Tobago; but he shall only be entitled to drive in Trinidad and Tobago a motor vehicle of the class for which he is authorised to drive by the permit of which he is the holder.

Exemption in case of valid driving permit held elsewhere. [17 of 1986].

(2) The Minister may by Notice published in the *Gazette* specify the countries to which subsection (1) applies.

(3) The holder of a valid driving permit referred to in subsection (1) who drives or is in charge of a motor vehicle on any road shall have such driving permit on his person or in the motor vehicle together with any travel document on which is certified his date of arrival in Trinidad and Tobago for production as required by subsection (4).

(4) A Transport Officer in uniform or a police officer may require the person referred to in subsection (3) to produce his driving permit together with the travel document on which is certified his date of arrival in Trinidad and Tobago for examination in order to ascertain the validity of the permit and his entitlement to drive in Trinidad and Tobago.

(5) A person who fails to comply with the requirements of this section is guilty of an offence and liable on summary conviction to a fine of five hundred dollars.

(6) In this section “valid driving permit” includes a valid driving licence or a valid certificate of competence to drive a motor vehicle issued in any country specified by the Minister under subsection (2).

57. The Licensing Authority shall keep a register of all driving permits issued showing the name and address of the holder, the date of issue, the class of vehicle authorised and a record of any convictions by a competent Court.

Register of driving permits.

LAWS OF TRINIDAD AND TOBAGO

50

Chap. 48:50 *Motor Vehicles and Road Traffic*

Period of driving permit. [8 of 1978 19 of 1978].

58. (1) Unless previously suspended, cancelled or revoked by competent authority, a driving permit shall expire upon the expiration—

- (a) of three years from the date of issue or renewal, in any case where on such date the holder of the permit has not yet attained the age of sixty-three years; and
- (b) of one year from the date of issue or renewal, in any case where on such date the holder of the permit has attained the age of sixty-three years.

(2) Notwithstanding subsection (1), a driving permit which is valid until 31st December 1977 is deemed to have been extended to such date in 1978 as is the anniversary date of the first issue of that permit; and if that permit was renewed in 1978 before 10th April, that renewal is deemed to be effective until the date in 1979 which is the anniversary date of the first issue of the permit.

Expiration of provisional permit. [14 of 1979].

59. Unless previously suspended, cancelled or revoked by competent authority, a provisional permit shall expire at the end of one year from the date of issue.

Re-issue of lost or defaced driving permit.

60. If a driving permit is lost, defaced, mutilated or rendered illegible, the Licensing Authority shall issue a new permit on payment of the prescribed fee without further driving test.

Restrictions on the issue of new driving permit after expiration of former one. [25 of 1997].

61. (1) On or after the expiration of a driving permit by effluxion of time and on application by the holder thereof for the issue of a new driving permit, the Transport Officer shall, subject to section 48 and of this section, issue a new permit to the applicant.

(2) The Licensing Authority may refuse to issue a driving permit to an applicant who has, within the three years preceding the application, been convicted of manslaughter arising out of the use of any motor vehicle or of any offence under section 70 or section 71 or of repeated offences under any one or more of the other sections of this Act or of the Regulations made under this Act.

(3) Any applicant aggrieved by any act, order or refusal of the Licensing Authority or of a Transport Officer may appeal to the Trinidad Transport Board whose decision shall be final.

***61A.** (1) Subject to subsection (2) an applicant for the issue of a new driving permit who is the holder of—

Charge for expired driving permit. [8 of 1996].

- (a) a permit which has expired for a period of not less than six months shall, in addition to the fee payable for its renewal, pay to the Licensing Authority the sum of three hundred dollars; and
- (b) a permit which has expired for a period of more than three years is required to pass a driving test in accordance with section 47,

prior to the issue of a new permit.

(2) Subsection (1) does not apply to an applicant who was absent from Trinidad and Tobago for the duration of the expiration of the permit.

PART V

DRIVING AND OTHER OFFENCES AND GENERAL CONDITIONS RELATING TO THE USE OF ROADS

62. (1) Subject as hereinafter provided, it shall not be lawful for any person to drive a motor vehicle of any class or description on any road—

Speed limits. [47 of 1956 17 of 1986 25 of 1997].

- (a) outside a built-up area at a speed greater than the speed specified in the Second Schedule as the maximum speed in relation to a vehicle of that class or description;
- (b) within a built-up area at a speed greater than the speed specified in the Second Schedule as the maximum speed in relation to a vehicle of that class or description;

Second Schedule.

*See Note on section 61A of the Act on page 4.

(c) whether outside or within a built-up area, in respect of which a special speed limit is imposed, at a speed exceeding the special speed limit imposed in relation to a vehicle of that class or description.

(2) The Minister may by Order impose a special speed limit with respect to any road, whether outside or within a built-up area, or any part of such road, in relation to motor vehicles generally or in relation to any class or description of motor vehicle.

(3) The Chief Technical Officer (Works) may by Order impose a special speed limit with respect to any bridge over which a road passes, whether outside or within a built-up area, in relation to motor vehicles generally or in relation to any class or description of motor vehicle.

(4) It shall be the duty of the Licensing Authority—

(a) to erect or cause to be erected and to maintain or cause to be maintained traffic signs in such positions as may be requisite for the purpose of securing that adequate guidance is given to drivers of motor vehicles as to the places where a length of road begins, and ceases, to be a road in respect of which a special speed limit is imposed and as to the special speed limit so imposed;

(b) to alter or remove traffic signs as may be requisite in pursuance of any Order made under subsection (2) or (3).

(5) Any person who drives a motor vehicle on any road in contravention of the provisions of subsection (1) is liable to a fine of five hundred dollars and to be disqualified from holding or obtaining a driving permit for such period as the Court shall think fit.

It shall be a good defence for any person charged with having contravened subsection (1)(c) to prove that at the time of the alleged contravention there was a failure to comply with subsection (4) by

reason of which he did not know that the length of road over which the contravention is alleged to have taken place was a length of road in respect of which the special speed limit had been imposed, and that he did not otherwise know of the imposition of the special speed limit in respect of such length of road.

(6) A person charged under this section shall not be liable to be convicted solely on the evidence of one witness to the effect that in the opinion of the witness the person charged was driving a motor vehicle at a speed greater than the maximum speed allowed.

(7) Subject to affirmative resolution of Parliament, the President may by Regulation amend the Second Schedule.

Second
Schedule.

(8) In this section—

“built-up area” means the City of Port-of-Spain, the City of San Fernando, the Borough of Arima, and any other area or road or portion thereof declared by Order of the Board to be a built-up area for the purposes of this section;

“special speed limit” means, in relation to the driving of any motor vehicle or a motor vehicle of any specified class or description on a road, a speed limit specifying a speed less than the speed which would be applicable in respect of that road and that class or description of motor vehicle under subsection (1)(a) or (b), as the case may be, and which is imposed under subsection (2) or (3).

63. (1) Any person who, except under and in accordance with the written permission of the Commissioner of Police, promotes or takes part in a race or trial of speed between motor vehicles on a road shall be liable to a fine of two thousand dollars and to imprisonment for six months.

Motor racing
and speed trials.
[47 of 1956].

(2) A person convicted of an offence under this section shall, unless the Court for special reasons thinks fit to order otherwise and without prejudice to the power of the Court to order a longer period of disqualification, be disqualified for a period of twelve months from the date of the conviction from holding or obtaining a driving permit.

Traffic signs.
[47 of 1956
17 of 1986].

47 of 1956.

64. (1) (a) The Licensing Authority may cause or permit traffic signs to be placed, erected or otherwise marked on or near any road, and may authorise any traffic signs so placed, erected or otherwise marked before 2nd March 1957 [that is, the date of commencement of the Motor Vehicles and Road Traffic (Amendment) Ordinance 1956] to be retained.

(b) The Licensing Authority may not cause or permit any traffic sign to be placed, erected or otherwise marked, or authorise the retention of any traffic sign, on or near any road in respect of which an Order of the Minister made under section 65 is in force, where such sign relates to the subject matter of such Order but is not in conformity with the provisions thereof.

(2) The size, colour and type of any traffic sign may be prescribed, and in such event the traffic sign shall be of the prescribed type and substantially of the prescribed size and colour and, where the size, colour and type thereof are not prescribed, shall be of a character authorised by the Licensing Authority.

(3) Every traffic sign erected, placed, marked or retained on or near any road shall, unless the contrary is proved, be deemed—

- (a) to have been lawfully so erected, placed, marked or retained; and
- (b) to be of the prescribed type and substantially of the prescribed size and colour, where the size, colour and type of the same have been prescribed, and in other cases to be of a character authorised by the Licensing Authority under this section.

(4) (a) Notwithstanding anything contained in subsection (3), after the commencement of the Motor Vehicles and Road Traffic (Amendment) Ordinance 1956 no person other than the Licensing Authority or any person acting under his directions may, except with the general or special permission in writing of the Licensing Authority—

- (i) erect, place or mark any traffic sign on or near any road; or

- (ii) retain any traffic sign erected, placed or marked, or caused to be erected, placed or marked, by him on or near any road.

(b) Without prejudice to the operation of subsection (5), nothing in this subsection shall apply to any traffic sign—

- (i) which the owner of any land erects, places, marks or retains, or causes to be erected, placed, marked or retained, on or near any private road which is situated on such land; or
- (ii) which any person erects, places, marks or retains, or causes to be erected, placed, marked or retained, on or near any road in pursuance of any authority conferred upon him by or under any law of Trinidad and Tobago other than this Act.

(c) For the purposes of this subsection—

“owner” in relation to any land includes any person in lawful occupation of such land; and

“private road” means any privately owned street, road or open space to which the public are granted access conditionally.

(5) The Licensing Authority may, by notice in writing, require the owner or occupier of any land on which there is a traffic sign, or any object which so closely resembles a traffic sign that it might reasonably be taken to be such a sign, to remove it, and if any such person fails to comply with such a notice, the Licensing Authority may himself effect or authorise the removal, doing as little damage as may be, and may, except where such sign was erected, placed, marked or retained by the Licensing Authority, recover in a Court of competent jurisdiction as a civil debt from the person so in default the expense incurred by him in doing so.

(6) The Licensing Authority or any person authorised by him in that behalf may, on any land near to or adjoining a road, cut branches of trees, or other vegetation, or remove any other thing which obscures or is likely to cause damage to a traffic

sign; but the Licensing Authority or any person authorised by him shall not exercise any powers under this section until after the expiration of three days' notice in writing of his intention to exercise the relevant power given to the occupier of the land or posted up conspicuously thereon.

(7) The Licensing Authority or any person authorised by him in that behalf may enter any land near to or adjoining a road—

- (a) for the purpose of exercising any power conferred by this section upon the Licensing Authority; or
- (b) for the purpose of replacing or maintaining traffic signs.

The Licensing Authority shall do as little damage as may be in executing any work authorised by this section.

(8) In any case where a constable is for the time being engaged in the regulation of traffic in a road, or where any traffic sign, being a sign for regulating the movement of traffic or indicating the route to be followed by traffic, has been lawfully placed, erected, marked or retained on or near any road, then in any such case any person driving or propelling any vehicle or any person riding or driving any animal—

- (a) who neglects or refuses to stop the vehicle or animal or to make the vehicle or animal proceed in or keep to a particular line of traffic when directed or signalled to do so by the constable in the execution of his duty; or
- (b) who fails to conform to the indication given by the traffic sign,

is guilty of an offence.

(9) Any person who—

- (a) unlawfully places, erects, marks or retains, or causes to be placed, erected, marked or retained, any traffic sign on or near any road; or
- (b) removes, defaces, damages, alters or obscures, or in any way interferes with, any traffic sign lawfully placed, erected, marked or retained on or near any road,

is liable to a fine of five hundred dollars or to imprisonment for three months.

(10) Notwithstanding the provisions of section 100, “prescribed” for the purposes of this section means prescribed by Order of the Minister and any such Order may revoke any Regulations in force in respect of the size, colour and type of any traffic sign.

(11) (a) If any person owning or having any interest in any property suffers pecuniary loss by reason of any damage to such property resulting from the exercise by the Licensing Authority of the powers conferred upon him by subsection (1) to cause traffic signs to be placed, erected or otherwise marked on or near any road, compensation shall be payable to such person in respect of such loss.

(b) If any difference arises between any person claiming compensation under paragraph (a) and the Licensing Authority as to whether such person is entitled to any such compensation or as to the amount of such compensation, such difference shall, on the written application of such person or of the Attorney General, be determined—

- (i) if the amount of the compensation claimed does not exceed two hundred and forty dollars, by a Magistrate; and
- (ii) if the amount of the compensation exceeds two hundred and forty dollars, by a Judge of the Supreme Court,

in like manner as if such Magistrate or Judge were a single arbitrator appointed pursuant to the provisions of the Arbitration Act, and the provisions of the said Act shall apply accordingly. Ch. 5:01.

(c) Compensation payable under this subsection shall be defrayed out of moneys provided for the purpose by Parliament.

65. (1) The Minister may by Order—

- (a) prohibit or regulate the parking of vehicles on any road; or

Parking of vehicles and one-way roads. [47 of 1956 17 of 1986].

(b) prohibit the driving of any vehicle on any specified road otherwise than in a specified direction.

(2) An Order made under this section may prescribe in respect of any contravention thereof a penalty not exceeding a fine of five hundred dollars or imprisonment for three months on summary conviction and any such Order may revoke any Regulations in force in respect of any of the matters specified in subsection (1).

(3) Where any provision in an Order made under this section conflicts with any Order made to meet the exigencies of a special occasion, or notice issued under section 68 the operation of such provision shall be suspended during the continuance in force of such last mentioned Order or notice, as the case may be.

Drivers to comply with traffic directions. [3 of 1969].

66. Where a police constable in uniform is engaged in the regulation of traffic in a road or where a traffic sign, being a sign of the prescribed size, colour and type or of another character authorised by the Licensing Authority under section 64 or where a notice of the Commissioner of Police under section 68 has been lawfully placed on or near a road, a person driving or propelling a vehicle who—

- (a) neglects or refuses to stop the vehicle or to make it proceed in or keep to, a particular line of traffic when directed to do so by the police constable in the execution of his duty; or
- (b) fails to comply with the indication given by the sign or the notice,

is liable on summary conviction for a first offence to a fine of three hundred dollars and on any subsequent conviction to a fine of seven hundred and fifty dollars.

Experimental traffic schemes. [3 of 1969 17 of 1986].

67. (1) Where it appears to the Commissioner of Police expedient to do so for the purpose of carrying out an experimental scheme of traffic control he may, with the consent

of the Minister, and after giving such notice as the Minister may direct, make Regulations for regulating vehicular traffic in any manner specified in the Third Schedule.

Third Schedule.

(2) Any provision contained in Regulations under this section may be made so as to apply at all times on specified days or during specified periods, and either throughout the day or during any specified part of the day, and to vehicular traffic generally or to such traffic of any class or description specified in the Regulations, and Regulations under this section may make different provision for different classes or descriptions of traffic.

(3) Any person who contravenes Regulations under this section is liable on summary conviction for a first offence to a fine of seven hundred and fifty dollars and on any subsequent conviction to a fine of one thousand dollars.

(4) Where there is any conflict or variance between Regulations made under this section and Regulations made by the President, the Regulations made by the President shall be read with such modifications as are necessary to bring them into conformity with those of the Commissioner under this section.

(5) Regulations under this section shall not continue in force for a period longer than three months after the making thereof, together with such further period (if any) not exceeding six months as the Minister may at any time before the expiration of the Regulations direct.

(6) Regulations made under this section shall be published in the *Gazette* and in at least one daily newspaper circulating in Trinidad and Tobago.

68. (1) Subject to this section in any case where a road is liable to be thronged or obstructed, the Commissioner of Police may by Order restrict or prohibit the use of that road or of any part thereof by vehicles or by vehicles of any particular class or description to such extent and subject to such conditions or exceptions as he may consider necessary.

Temporary prohibition or restriction of traffic on roads. [3 of 1969].

(2) The Commissioner may at any time by notice restrict or prohibit temporarily the use of a road or any part of a road by vehicles or by vehicles of any particular class or description for the purpose of—

- (a) avoiding danger or obstruction to persons or other traffic using the road or any other road; or
- (b) preventing damage to the road or to any building on or near the road; or
- (c) facilitating the passage of vehicular traffic on the road or any other road or from any premises.

(3) The provisions which may be made by a traffic regulation, Order or notice shall be any provision prohibiting, restricting or regulating the use of a road or any part of the width thereof by vehicular traffic or by such traffic of any class or description specified in the Order, either generally or subject to exceptions so specified, and either at all times or at times on days or during periods so specified and, without prejudice to the generality of this subsection, any provision—

- (a) requiring such traffic to proceed in a specified direction or prohibiting its so proceeding;
- (b) specifying the part of the carriageway to be used by such traffic proceeding in a specified direction;
- (c) prohibiting or restricting the parking, stopping or waiting of vehicles or the loading and unloading of vehicles;
- (d) prohibiting the use of roads by through traffic;
- (e) prohibiting or restricting overtaking;
- (f) regulating the speed of vehicles.

(4) An Order made or notice issued under the above provisions of this section may suspend any statutory provision of a description which could have been contained in the Order or notice or, in the case of an Order under subsection (1), any statutory provision prohibiting the use of roads by through traffic, and any such provision (other than one contained in the Order or notice) shall have effect subject to the Order or notice.

(5) An Order under subsection (1) shall not without the approval of the Minister continue in force for a longer period than one month from the making thereof.

(6) A notice issued under subsection (2) shall not continue in force for a longer period than fourteen days from the date thereof.

(7) Any person who uses or permits the use of a vehicle in contravention of a restriction or prohibition imposed by an Order under subsection (1) is liable on summary conviction for a first offence to a fine of one hundred and fifty dollars and on any subsequent conviction to a fine of three hundred dollars.

(8) Any person who unlawfully and without just cause or excuse removes from the position where it is placed, alters or defaces a notice of the Commissioner under subsection (2) is liable to a fine of seventy-five dollars.

69. (1) Notwithstanding any rule of law to the contrary, but subject to this section, a motor vehicle shall not be parked—

- (a) at any time of the day or night on any portion of Knox Street between St. Vincent Street and Abercromby Street in the City of Port-of-Spain, by any person not being a member of the House of Representatives or of the Senate or his servant or agent;
- (b) at such times and on such portion of any road as are designated by the Minister by Notification, by any person not being—
 - (i) a member of the diplomatic corps and his staff (duly authorised by the Head of Mission) representing such countries and institutions as are specified in the Notification or his servant or agent;
 - (ii) a person belonging to such other classes of persons as are specified in the Notification or his servant or agent,

and any statutory provision respecting parking on such roads (other than one contained in the Notification) shall have effect subject to the Notification.

Restrictions on parking in certain streets. [3 of 1969].

(2) Where a member of the House of Representatives or of the Senate or a member of the diplomatic corps or his staff or other person as is mentioned in subsection (1)(b)(ii) or their servants or agents parks a motor vehicle on a road pursuant to this section, the motor vehicle shall have attached to it, in the prescribed position, a special identification mark of the kind prescribed by the Minister.

(3) Any person who contravenes the provisions of subsection (1) is liable to a fine of one hundred and fifty dollars.

Driving when under influence of liquor. [22 of 2000].

70. (1) Any person who, when driving or attempting to drive or when in charge of a motor vehicle on a road, is under the influence of drink or a drug to such an extent as to be incapable of having proper control of the vehicle, is liable on first conviction to a fine of eight thousand dollars and to imprisonment for three years and on any subsequent conviction to a fine of fifteen thousand dollars and to imprisonment for five years.

Disqualification from driving upon conviction.

(2) A person convicted of an offence under this section shall, without prejudice to the power of the Court to order a longer period of disqualification, be disqualified for a period of three years from the date of the conviction for holding or obtaining a driving permit, and on a second conviction for a like offence he shall be permanently disqualified for holding or obtaining a driving permit.

(3) Any constable may arrest without a warrant any person committing an offence under this section.

Causing death by dangerous driving. [22 of 2000].

71. (1) Any person who causes the death of another person by driving a motor vehicle dangerously on a road, commits an offence and is liable on conviction on indictment to imprisonment for fifteen years.

(2) A person convicted of an offence under this section shall, without prejudice to the power of the Court to order a longer period of disqualification, be disqualified for a period of fifteen years from the date of the conviction from holding or obtaining a driving permit, and on a second conviction for a like offence he shall be permanently disqualified from holding or obtaining a driving permit.

(3) Any constable may arrest without warrant the driver of any motor vehicle who commits an offence under this section within his view, if he refuses to give his name and address, or if the constable has reason to believe that the name or address so given is false, or if the motor vehicle does not bear an identification plate.

71A. (1) A person who drives a motor vehicle dangerously on a road commits an offence and is liable on summary conviction to a fine of ten thousand dollars and to imprisonment for five years. Dangerous driving. [22 of 2000].

(2) A person convicted of an offence under this section shall, without prejudice to the power of the Court to order a longer period of disqualification, be disqualified for a period of twelve months from the date of the conviction from holding or obtaining a driving permit, and on a third conviction for a like offence he shall be permanently disqualified from holding or obtaining a driving permit.

(3) Section 71(3) shall apply where an offence is committed under this section.

71B. (1) For the purposes of sections 71 and 71A a person is to be regarded as driving dangerously if— Interpretation. [22 of 2000].

- (a) the way in which he drives falls below what would be expected of a competent and careful driver; and
- (b) it would be obvious to a competent and careful driver that driving in that way would be dangerous.

(2) A person is also to be regarded as driving dangerously for the purposes of sections 71 and 71A if it would be obvious to a competent and careful driver that driving the vehicle in its current state would be dangerous. In determining the state of a vehicle, regard may be had to anything attached to or carried on or in it and to the manner in which it is attached or carried.

(3) In subsections (1) and (2) “dangerous” refers to danger either of injury to any person or of serious damage to

property; and in determining for the purposes of those subsections what would be expected of, or obvious to, a competent and careful driver in a particular case, regard shall be had not only to the circumstances of which he would be expected to be aware but also to any circumstances shown to have been within the knowledge of the driver.

Careless driving.

72. Any person who drives a motor vehicle on a road without due care and attention or without reasonable consideration for other persons using the road, is liable to a fine of one thousand dollars and to be disqualified for holding or obtaining a driving permit for such period as the Court thinks fit. On a second or subsequent conviction for a like offence the period of disqualification shall not be less than one month.

Warning to be given of intended prosecution. [22 of 2000].

73. (1) Subject to subsections (2) and (3), where a person is prosecuted for an offence under any of the preceding sections relating respectively to the maximum speed at which motor vehicles may be driven, dangerous driving or causing death by dangerous driving, and to careless driving, he shall not be convicted unless either—

- (a) he was warned on the day the offence was committed that the question of prosecuting him for an offence under some one or other of the sections aforesaid would be taken into consideration; or
- (b) within fourteen days of the commission of the offence a summons for the offence was served on him; or
- (c) within the said fourteen days a notice of the intended prosecution specifying the nature of the alleged offence and the time and place where it is alleged to have been committed was served on or sent by registered post to him or to the person registered as the owner of the vehicle at the time of the commission of the offence.

(2) Failure to comply with the requirement of subsection (1) shall not be a bar to the conviction of the accused in any case where the Court is satisfied that—

- (i) neither the name and address of the accused nor the name and address of the registered owner of the vehicle, could with reasonable diligence have been ascertained in time for a summons to be served or for a notice to be served or sent as aforesaid; or
- (ii) the accused by his own conduct contributed to the failure.

(3) The requirement of subsection (1) shall in every case be deemed to have been complied with unless and until the contrary is proved.

74. (1) (a) Any person who uses a vehicle without the consent of the owner or other lawful authority, is guilty of an offence.

Taking vehicle without consent of owner.

(b) A person shall not be convicted under this section if he proves either—

- (i) that he had good reason to believe, and did in fact believe, that the owner of the vehicle would, had he been present, have consented to the vehicle being used in the manner in which it was used; or
- (ii) that he had reasonable cause to believe, and did in fact believe, that he had lawful authority to use the vehicle.

(2) If any person is convicted under this section, the Magistrate may, if he thinks fit, either in addition to or without inflicting any punishment, order that the person convicted do pay to the owner of the vehicle either or both of the following sums, namely—

- (a) such sum as, in the opinion of the Magistrate, would have been charged if the vehicle had been hired by the person convicted;

(b) such sum as, in the opinion of the Magistrate, represents fair compensation for any damage done to and for the use of the vehicle.

(3) If on the trial of any indictment for stealing a vehicle the jury are of opinion that the defendant was not guilty of stealing the vehicle but was guilty of an offence under this section, the jury may find him guilty of an offence under this section and thereupon he shall be liable to be punished accordingly.

(4) Any constable may arrest without a warrant any person suspected by him of having committed an offence under this section.

Interfering with motor vehicle.

75. Any person who, without the knowledge or permission of the owner, gets onto or attempts to manipulate any of the levers, the starter, brakes or machinery of a motor vehicle, or in any way interferes with or damages a motor vehicle while the vehicle is on a road or parking place, is guilty of an offence; but a person shall not be convicted under this section when such motor vehicle is obstructing his own or another motor vehicle.

Restrictions on persons being towed on bicycles.

76. (1) It shall not be lawful for more than one person to be carried on a road on a bicycle not propelled by mechanical power unless it is constructed for the carriage of more than one person.

(2) If any person is carried on such a bicycle in contravention of this section, each of the persons carried shall be liable on first conviction to a fine of two hundred dollars and on any subsequent conviction to a fine of four hundred dollars.

(3) In this section references to a person carried on a bicycle shall include reference to a person riding a bicycle.

Restriction on cyclists riding abreast or holding on to other moving vehicles.

77. (1) It shall not be lawful for more than two persons to ride abreast on a road either upon motorcycles or upon bicycles not propelled by mechanical power; but a person shall not be convicted under this section in respect of the overtaking of two persons so riding and in the absence of other traffic on the road at the point of overtaking.

(2) It shall not be lawful for any person while riding a motorcycle, or a bicycle not propelled by mechanical power, on a road—

- (a) to hold on to any other moving vehicle; or
- (b) to ride such motorcycle or bicycle without at least one hand being on the handle bars of such motorcycle or bicycle.

(3) It shall not be lawful for more than one person in addition to the driver to be carried on any two-wheeled motorcycle, nor shall it be lawful for any such one person to be so carried otherwise than sitting astride the motorcycle and on a proper seat securely fixed to the motorcycle behind the driver's seat.

(4) Any person who contravenes this section is liable on first conviction to a fine of one hundred dollars and on any subsequent conviction to a fine of two hundred dollars.

78. (1) Any person who throws or distributes from any vehicle on any road any picture, print or any other article of whatsoever nature by way of advertisement, or any handbill, is liable to a fine of four hundred dollars and to imprisonment for two months.

Distribution of advertisements from vehicles prohibited. [11 of 1959].

(2) Where an offence has been committed under subsection (1) by any person other than the driver or person in charge of the vehicle used in connection with such offence, the driver or person in charge of such vehicle shall be deemed to be guilty of an offence under subsection (1) unless he satisfies the Court before which he is tried that he could not reasonably have prevented or stopped the commission of such offence.

79. (1) Where, owing to the presence of a vehicle on a road, an accident occurs whereby injury or damage is caused to any person, animal or property, the driver of such vehicle shall immediately stop, and—

Duty to stop, give aid, and report in case of accident.

- (a) if any person has been injured in the accident, the driver shall render such person aid, and if the person wishes to be taken to hospital or to a doctor, or is unconscious, convey or cause to be conveyed the injured person without delay to the nearest hospital or to a doctor;

- (b) if requested by the injured person or by the owner of the damaged property or some person on such owner's behalf, the driver shall give his name and address and particulars of his driving permit and the name and address of the owner of the vehicle;
- (c) unless a report is made by the driver at the time and place of the accident to a member of the Police Service, the person riding in, driving or in charge of the vehicle shall proceed with all proper despatch to the nearest Police Station or police constable in uniform and shall report the accident, and shall give his name and address and the name and address of the owner of the vehicle and the names of any persons in the vehicle at the time of the accident.

(2) Any person who contravenes this section is guilty of an offence.

PART VI

LEGAL PROCEEDINGS, SUSPENSION AND
CANCELLATION OF DRIVING PERMITS

Power to
convict for
reckless or
dangerous
driving on
trial for
manslaughter.

80. Upon the trial of a person who is indicted for manslaughter in connection with the driving of a motor vehicle by him, it shall be lawful for the jury, if they are satisfied that he is guilty of an offence under section 71, to find him guilty of that offence, whether or not the requirements of section 73 have been satisfied as respects that offence.

Power to
proceed on
charge for
careless driving
on hearing of
charges under
s.70 or s.71A.
[22 of 2000].

81. Where a person is charged summarily before a Magistrate with an offence under section 70 or section 71A and the Magistrate is of the opinion that the offence is not proved, then, at any time during the hearing or immediately thereafter, the Magistrate may, without prejudice to any other powers possessed by him, direct or allow a charge for an offence under section 72 to be preferred forthwith against the defendant and may thereupon proceed with that charge. The defendant or his Attorney-at-law shall be informed of the new charge and be given an opportunity, whether by way of

cross-examining any witness whose evidence has already been given against the defendant or otherwise, of answering the new charge, and the Magistrate shall, if he considers that the defendant is prejudiced in his defence by reason of the new charge being preferred, adjourn the hearing.

82. (1) The Court before which a person is convicted of any offence in connection with the driving of a motor vehicle may in addition to any other penalty provided for such offence, order that the offender be disqualified for a stated period or permanently for obtaining a driving permit either generally or limited to the driving of a motor vehicle of any particular class and where the offender holds a driving permit the Court shall require him to produce the permit and upon the making of an order of disqualification shall forfeit the permit and return it to the Licensing Authority.

Power of Court to order disqualification from obtaining a driving permit and to cancel permit. [14 of 1979].

(2) A person who is disqualified under this Act for holding or obtaining a driving permit may, after the expiration of six months from the date of the disqualification, apply to the Court by which he was disqualified to remove the disqualification and the Court may, as it thinks proper, having regard to the character of the person disqualified and his conduct subsequent to the disqualification, the nature of the offence and any other circumstances of the case either by order remove the disqualification as from the date specified in the order or refuse the application.

(3) Where an application is refused under this section a further application shall not be entertained within six months of the date of the refusal.

(4) Particulars of a conviction or disqualification or of the removal of a disqualification under this Act shall be furnished to the Transport Commissioner.

(5) The costs of any application referred to in this section may be borne in whole or in part by the applicant, as the Court may order.

(6) In this section “driving permit” includes a “provisional permit”.

Right of appeal.

83. A person who by virtue of an order of a Court under section 82 is disqualified for holding or obtaining a driving permit may appeal against the order in the same manner as against a conviction, and the Court may, if it thinks fit, pending the appeal, suspend the operation of the order.

Production of offender's Record of Conviction. [14 of 1979].

84. Where a person who holds a driving permit is convicted of an offence in connection with driving a motor vehicle, the Court may in order to impose an appropriate penalty, require the Transport Commissioner to produce for its inspection the offender's Record of Conviction and the Transport Commissioner where so required shall furnish the Court with the offender's Record of Conviction or with a certified copy thereof.

Custody of permit while suspended or cancelled.

85. A Court which suspends or cancels a driving permit, or declares a person disqualified for obtaining a driving permit shall forthwith send to the Licensing Authority every suspended or cancelled driving permit. At the expiration of the period of suspension, the Licensing Authority shall return the permit to the owner on demand.

Where the disqualification to which a person has become subject is limited to the driving of a motor vehicle of a particular class or description, the Licensing Authority shall forthwith after the receipt of the driving permit indicate on the permit in the usual manner the class or description of vehicle which the holder of the permit is not thereby authorised to drive, and the permit shall then be returned to the holder. At the expiration of the period of disqualification, the holder shall again forward the permit to the Licensing Authority, who shall thereupon indicate on the permit that the restriction imposed during the period of disqualification has been removed.

Suspended permit to be of no effect.

86. A driving permit suspended by a Court shall, during the period of suspension, be of no effect, and a person whose permit is suspended, or who is declared by the Court to be disqualified for obtaining a permit, shall, during the period of such suspension or disqualification, be disqualified for obtaining a driving permit.

86A. (1) Notwithstanding any other written law, the Licensing Authority may suspend for a period not exceeding six months, every driving permit issued under this Act to a person where the person's record as a driver of motor vehicles or his conduct or habits as a driver establishes that it would not be in the interests of the public safety for him to hold a driving permit issued under this Act or that the person is not competent to drive a motor vehicle.

Licensing Authority may suspend driving permit. [21 of 2000].

(2) For the purpose of establishing that it would not be in the interest of public safety for a person to hold a valid driving permit or that such a person is not competent to drive a motor vehicle, the President may prescribe by Regulations, a system of awarding penalty points against a person for the commission of an offence under this Act or the Motor Vehicles and Road Traffic (Enforcement and Administration) Act or the Regulations made under this or that Act.

Ch. 48:52.

(3) The Regulations referred to in subsection (2) shall specify—

- (a) the maximum number of points to be awarded against a person before it may be established that it would not be in the interest of public safety for him to hold a valid driving permit or that the person is not competent to drive a motor vehicle;
- (b) the period during which the points shall remain on a person's driving record.

(4) The Licensing Authority may exercise the power conferred upon it by this section to suspend the driving permit of a person, at such time after the maximum number of points, referred to in subsection (3), has been awarded against the person as the Authority thinks fit.

(5) Where the points awarded against a person under the Regulations made under subsection (2) reach fifty per cent of the maximum number at which the Licensing Authority may suspend the driving permit of that person under this section, the Authority shall give notice in writing to the person.

(6) Where a person is disqualified by an order of a Court from holding or obtaining a driving permit for such period of time as may be specified in the order, every point awarded against him under the Regulations made under subsection (2) shall thereupon be cancelled.

Ch. 48:52.

(7) Where a holder of a valid driving permit commits on a single occasion, two or more offences under this Act or the Motor Vehicles and Road Traffic (Enforcement and Administration) Act or the Regulations made under this or that Act, penalty points shall be awarded against him only for the offence committed by him and in respect of which the largest number of points may be awarded against a person.

(8) For the purposes of this section, a person shall be deemed to have committed an offence under the Motor Vehicles and Road Traffic (Enforcement and Administration) Act or the Regulations made under subsection (2) if he pays the prescribed penalty under section 5 of that Act, except that a person who appeals a fixed penalty in accordance with section 3(7) of the Motor Vehicles and Road Traffic (Enforcement and Administration) Act, shall not be deemed to have committed the offence until the appeal has been adjudicated against him.

Permit holder may show cause why driving permit should not be suspended. [21 of 2000].

86B. (1) The Licensing Authority shall, before suspending under section 86A the driving permit of a person, give that person notice in writing of its intention to do so, specifying a date not less than fourteen days after the date of the notice, upon which such suspension shall be made and calling upon the person to show cause to the Authority why the driving permit should not be suspended.

(2) Upon the person failing to show cause within the period referred to in subsection (1) and if the Licensing Authority after taking into consideration any facts in mitigation, decides to suspend the driving permit of the person pursuant to section 86A, the Authority shall forthwith, in writing, notify the person of the suspension.

(3) An order of suspension made under section 86A shall not take effect until the expiration of fourteen days after the Licensing Authority has informed the person concerned of the order.

(4) A person whose driving licence has been suspended by the Licensing Authority under this section may, within fourteen days of the receipt of the notice referred to in subsection (2), appeal to a Court of competent jurisdiction against that decision and the decision of that Court shall be final.

86C. (1) The Licensing Authority shall, upon suspending a driving permit under section 86A, require the person concerned to surrender the driving permit to the Licensing Authority.

Surrender and return of driving permit.
[21 of 2000].

(2) Any person whose driving permit has been suspended under section 86A shall forthwith surrender the driving permit to the Licensing Authority on request pursuant to subsection (1).

(3) Subject to a decision of the Court following an appeal referred in section 86B(4), a driving permit suspended by the Licensing Authority shall be of no effect and a person whose permit is so suspended shall, during the period of such suspension, be disqualified for obtaining a driving permit.

(4) At the expiration of the period of suspension, the Licensing Authority shall forthwith return the driving permit to the holder thereof and the points awarded against him shall be cancelled.

87. (1) If and when any person is charged with manslaughter arising out of the use of any motor vehicle or with contravening the provisions of section 70 or section 71, it shall be lawful for the Licensing Authority to order the suspension of the driving permit of the person so charged pending the determination of the charge.

Temporary suspension of permit pending determination of charges.

(2) Any such permit so suspended shall on demand by any constable be surrendered to such constable who shall forthwith forward the same to the Clerk of the Court before which the person so charged is to appear.

88. If any person who under the provisions of this Part is disqualified for holding or obtaining a driving permit applies for or obtains a permit while he is so disqualified, or if any person

Fraudulent application for driving permit.

while he is so disqualified drives a motor vehicle or, if the disqualification is limited to the driving of a motor vehicle of a particular class or description, a motor vehicle of that class or description on a road, or if any person who has been refused a permit applies for or obtains a permit without disclosing such refusal, he is liable to a fine of two thousand dollars or to imprisonment for six months.

PART VII

GENERAL

Fees and duties.
First Schedule.

89. (1) The fees and duties specified in the First Schedule shall be payable to the Licensing Authority in respect of the several matters to which they are applicable.

(2) All fees and duties received by the Licensing Authority shall be paid to the Comptroller of Accounts on account of the general revenue of Trinidad and Tobago.

(3) Such percentage or proportion of the annual licence duties in respect of motor vehicles collected under this Act by the Licensing Authority which are paid by the owners of motor vehicles who are resident within any City or Municipality shall be paid to the Council of such City or Municipality by the Comptroller of Accounts as may be directed by the President.

(4) Subject to affirmative resolution of Parliament, the President may by Regulations amend, vary, suspend or revoke the provisions of the First Schedule.

89A. (Repealed by Act No. 9 of 1997).

Fraudulent
imitation, etc.,
of documents.

90. Any person who fraudulently imitates, alters, mutilates, destroys or uses, or fraudulently lends or allows to be used by any other person any identification mark, motor vehicle licence, certificate of registration or driving permit issued or deemed to have been issued under this Act is liable to a fine of two thousand dollars and to imprisonment for six months.

91. (1) Any person who contravenes this Act is, unless otherwise specifically provided, liable to a fine of one thousand dollars or to imprisonment for six months.

Offences and general penalty. [30 of 1952, 8 of 1978* and 14 of 1979].

(2) Any person who contravenes the provisions of any Regulations made under this Act is, unless otherwise specifically provided, liable to a fine of one thousand dollars or to imprisonment for six months.

(3) The driver of a motor vehicle who stands for hire at any road or place not appointed under this Act for the purpose, or who contravenes any Order made under this Act, shall be guilty of an offence under this Act.

(4) Unless otherwise expressly provided, all offences under this Act may be prosecuted, and all penalties incurred may be imposed or recovered, in the manner provided by the Summary Courts Act.

Ch. 4:20.

92. Nothing in this Act shall affect any liability of the driver or owner of a motor vehicle by virtue of any Act or at Common Law.

Liability at Common Law.

93. (1) Any driver or conductor of a motor vehicle who commits an offence under this Act or any Regulations made thereunder and refuses to give his name and address or gives a false name or address is guilty of an offence; and it shall be the duty of the owner of the motor vehicle if required to give any information which it is within his power to give and which may lead to the identification and apprehension of the driver or conductor, and any owner who fails to do so within four days of his being notified of such request is guilty of an offence.

Refusing to give name or address or giving false name or address.

(2) Any constable may arrest without a warrant the driver or conductor of any motor vehicle who within view commits any offence under this Act or under the Regulations unless the driver or conductor either gives his name and address or produces his permit for examination.

94. If any person in or in connection with an application for a motor vehicle licence or the registration of a motor vehicle, or a

Giving false information.

*Came into operation on 10th April 1978—GN 54/1978.

driving permit or the endorsement of such a permit, or any change or correction in a motor vehicle licence or the registration of a motor vehicle or in giving any information lawfully demanded or required under this Act or any Regulations made thereunder makes any statement which to his knowledge is false, or in any material respect misleading, he is liable to a fine of two thousand dollars and to imprisonment for six months.

Duplicate licences, permits and certificates.

95. Any authority or person having power to issue any certificate or licence under this Act shall, on proof to his satisfaction that such certificate or licence has been lost or destroyed, and on payment of the prescribed fee, issue a duplicate of the certificate or licence to the person entitled thereto.

Liability of driver and person in charge of vehicle for offences.

96. (1) If—

- (a) any motor vehicle is used which contravenes any provision of this Act or of any Regulation, or of any Order lawfully made under this Act or any Regulation; or
- (b) any motor vehicle is used in such a state or condition or in such a manner as to contravene any such provision; or
- (c) anything is done or omitted in connection with a motor vehicle in contravention of any such provision,

then, unless otherwise expressly provided by this Act, the driver or person in charge of the motor vehicle at the time of the offence is guilty of an offence unless the offence was not due to any act, omission, neglect or default on his part.

(2) Any person authorised in writing by the Licensing Authority may, at all reasonable times, enter any premises for the purpose of ascertaining whether any vehicle is kept on such premises contrary to this Act, and for the purpose of inspecting any vehicle on such premises.

Power to require motor vehicles licensed according to M.G.W. to be weighed. [25 of 1997].

97. (1) The driver or other person in charge of a motor vehicle or trailer registered according to its maximum gross weight may, on demand by any person authorised in writing by the Licensing Authority or by a constable, be required to satisfy such person or constable that the load which is being carried on such motor vehicle

or trailer does not contravene the provisions of the registration or this Act or any Regulations made thereunder, and may be required by such person or constable to drive him with such vehicle or trailer to the nearest weighbridge for the purpose of weighing such load.

(2) Any person who fails to comply with a request to proceed to the nearest weighbridge as aforesaid is guilty of an offence and may be arrested forthwith without a warrant and he is liable to a fine of four hundred dollars. The vehicle or trailer may be detained at the expense and risk of the owner and taken to a place for safe keeping until such request is complied with, and any excess load found on weighing shall first be removed before the vehicle or trailer is permitted to proceed on its journey.

(3) The Licensing Authority or any person authorised by the Licensing Authority may, before registration (including a renewal) in respect of a motor vehicle or trailer, require such motor vehicle or trailer to be weighed by and at the expense of the owner in the presence of a person authorised by the Licensing Authority.

98. (1) If by reason of an offence against this Act any injury is caused to any road or bridge, the authority responsible for the repair of the road or bridge may cause such injury to be made good, and may, either before or after the injury is made good, recover the estimated or actual cost thereof from the owner of the motor vehicle by the use of which the offence was committed.

Recovery of damage to road or bridge.

(2) A certificate under the hand of the Chief Technical Officer (Works), or any person authorised by him in that behalf, of the amount of the cost of making good such injury shall, without proof of signature, be *prima facie* evidence of the amount payable by the owner of the vehicle.

99. If in any proceedings under this Act any question arises whether a motor vehicle does or does not comply with any provision of this Act or any Regulations made thereunder the certificate of any person appointed by the Public Service Commission, in the exercise of its power under the Constitution, as a Transport Officer that he has examined the vehicle and as to the result of his

Certificate as to damage to be admissible in evidence. [25 of 1997].

examination shall be admissible in evidence and shall be sufficient *prima facie* evidence of any fact or opinion stated therein relating to the matter in question, and the Court shall not permit the officer to be called for cross-examination on the certificate unless contrary evidence is given which appears to the Court to be credible, or unless for any reason the Court considers cross-examination to be necessary in the interests of justice.

Regulations.
[*47 of 1956
†32 of 1964
12 of 1961
11 of 1965
25 of 1997].

100. Subject to affirmative resolution of Parliament, the Minister may make Regulations in respect of all or any of the following matters:

- (a) anything which by this Act may or is to be prescribed;
- (b) the forms to be used under this Act;
- (c) the construction, fittings, dimensions and design of any motor vehicle;
- (d) the character and nature of horns or other instruments capable of giving audible and sufficient warning of motor and other vehicles and regulating their use;
- (e) the number, position and kind of lights and reflectors to be carried on motor and other vehicles and the times during which they are to be exhibited;
- (f) the duties and powers of Motor Vehicles Inspectors with regard to the inspection of motor and other vehicles;
- (g) the inspection of motor and other vehicles and the times, places and manner of such inspection;
- (h) the form of identification marks to be fixed on motor vehicles and trailers in respect of registration and licensing and the sizes and colour of the letters of and the manner of displaying such marks;

*Act No. 47 of 1956 deleted the former paragraphs (k) and (l) of this section but provided for any Regulations made under them to continue in force.

†Section 10 of Act No.32 of 1964 provides that nothing in this section or in any Regulations made under this Act (the Motor Vehicles and Road Traffic Act) relating to the granting or operation of concessions shall apply to motor omnibuses operated by Government under that Act.

- (i) the classification of roads and the prohibition or restriction of the use of any classified roads by vehicles of any specified class or description;
- (j) the precedence of vehicles and pedestrians respectively at and in the vicinity of crossings;
- (k) the issue of licences to drivers of taxis by the Licensing Authority and the conditions to be observed by the holders of such licences;
- (l) the badges and uniforms to be worn by drivers and conductors of public service vehicles and the conduct of drivers, conductors and passengers;
- (m) the prevention of indecent or immoral behaviour in taxis;
- (n) passenger fares and tolls in respect of public service vehicles;
- (o) the maximum hours of employment of persons as drivers of goods vehicles;
- (p) generally, for the better carrying out of the provisions of this Act and in particular for the safety, control and regulation of traffic and the use of vehicles or any class of vehicles on any road and the conditions under which they may be used;
- (q) health, safety or environmental matters with respect to the registration of motor vehicles or trailers including the prescribed vehicle emissions, use of unleaded fuels, and vehicle specifications for motor vehicles or classes of motor vehicles for the purpose of registration;
- (r) passenger transport.

101. (Repealed by Act No. 25 of 1997).

102. (1) Regulations under section 100 may make provision as to the conduct of persons licensed to act as drivers or conductors of public service vehicles when acting as such.

(2) Any person to whom Regulations having effect by virtue of this section apply, who contravenes any of the Regulations, is liable to a fine of one hundred and fifty dollars.

Regulation of
conduct of
drivers and
conductors.
[11 of 1965
47 of 1980
25 of 1997].

Regulation of
conduct of
passengers.
[11 of 1965
25 of 1997].

103. (1) Regulations under section 100 may make provision generally as to the conduct of passengers in public service vehicles and in particular for—

- (a) authorising the removal from a public service vehicle of a person infringing the Regulations by the driver or conductor of the vehicle or on the request of the driver or conductor by a police constable;
- (b) requiring a passenger in a public service vehicle who is reasonably suspected by the driver or conductor thereof of contravening the Regulations to give his name and address to a police constable or to the driver or conductor on demand;
- (c) requiring a passenger to declare, if so requested by the driver or conductor, the journey he intends to take or has taken in the vehicle, and to pay the fare for the whole of that journey and to accept any ticket provided therefor;
- (d) requiring on demand being made for the purpose by the driver or conductor or other person authorised by the Corporation established under the Public Transport Service Act production during the journey and surrender at the end of the journey by the holder thereof of any ticket issued to him;
- (e) requiring a passenger, if so requested by the driver or conductor, to leave the vehicle on the completion of the journey the fare for which he has paid;
- (f) requiring the surrender by the holder thereof on the expiry of the period for which it is issued of a ticket issued to him.

Ch. 48:02.

(2) Any person who contravenes, a provision of Regulations having effect by virtue of this section is liable to a fine of seventy-five dollars.

- 104.** (1) Regulations under section 100 may make provision with respect to public service vehicles providing for—
- (a) the determination by or under the Regulations of the number of the seated passengers and standing passengers respectively whom a vehicle is constructed or adapted and fit to carry;
 - (b) the determination by or under the Regulations of the number of such passengers respectively who may be carried in a vehicle;
 - (c) the marks to be carried on a vehicle showing the number aforesaid and the manner in which those marks are to be carried.

Control of number of passengers. [11 of 1965 25 of 1997].

(2) Any person who contravenes a provision of Regulations having effect by virtue of this section is liable to a fine of seven hundred and fifty dollars.

- 105.** (1) The Minister may make Regulations generally as to the conduct of persons using a station and in particular—
- (a) for appointing any place, being the property of the Corporation or being part of a road, a station for public service vehicles;
 - (b) in the case of a road, for authorising the Corporation to do all things as are necessary to adapt the station for use as such, and in particular to provide and maintain waiting rooms, ticket offices, refreshment places and lavatories and other similar accommodation in connection therewith;
 - (c) for authorising the Corporation to make reasonable charges for the use of, or to let on hire to any person, any accommodation so provided; and
 - (d) for the use of any such accommodation.

Control of bus terminals and coach stations. [11 of 1965 25 of 1997].

(2) In this section “Corporation” means the Corporation established under the Public Transport Service Act, and “station” includes bus stops and coach stations and terminals that may be used by public service vehicles belonging to the Corporation as parking places.

Ch. 48:02.

Offences in connection with Regulations. [11 of 1965 25 of 1997].

106. Regulations under sections 100, 102, 103 and 104 may contain provisions for imposing on any person contravening the Regulations a fine recoverable on summary conviction of fifteen hundred dollars or imprisonment for three months for each offence.

Parking in grounds, etc., of public officers restricted. [11 of 1963].

107. (1) Notwithstanding any other provision of this Act, no person shall park or cause any motor vehicle to be or to remain parked in or on any grounds or other open space adjoining or attached to any public building unless he has been granted permission by a person authorised in that behalf under subsection (2).

(2) The President may by Order authorise a public officer specified in the Order to grant permission to any person to park a vehicle in or on any grounds or open space adjoining or attached to a public building expressed in the Order to be under the control of that public officer.

(3) A public officer referred to in subsection (2) shall issue to every person to whom he grants permission to park in or on any such grounds or open space a distinguishing mark or symbol which such person shall affix to the lower left front windshield of the vehicle.

(4) Any person who contravenes subsection (1) is liable to a fine of three hundred dollars or to imprisonment for three months.

(5) In this section, “public buildings” means any building occupied for use as offices by any Government Ministry or Department and includes a building used as a Court of law; “grounds” includes forecourt, courtyard, footpath, driveway and alleyway.

Powers of police where vehicles parked in contravention of Act or left on road. [11 of 1963].

108. (1) Where a vehicle is parked in contravention of any provisions of this Act or of any Regulations or Orders made thereunder, or is left on any road in such a manner that it is likely to cause any obstruction to persons lawfully using any such road, any member of the Police Service may—

(a) require the driver or other person in control or in charge thereof to remove it or cause it to be

removed, and any person who fails to comply with any such requirement is liable to a fine of three hundred dollars or to imprisonment for three months;

- (b) if the driver or other person in control or in charge of such vehicle cannot be found or refuses to remove it when required to do so, remove such vehicle or arrange for it to be removed from the place in which it is parked to a place of safe custody either by towing or driving the vehicle or in such other manner as he may think necessary.

(2) When any member of the Police Service removes or provides for the safe custody of any motor vehicle or arranges for any person to remove it or provide for its removal under subsection (1) then, except upon proof of failure to exercise reasonable care, neither such member of the Police Service nor any such other person shall be liable in any action or demand for any damages arising from the loss or damage to such vehicle in the course of its removal or otherwise.

109. (1) Where any motor vehicle is removed to a place of safe custody under section 108 such vehicle shall not be released to the owner thereof unless there is paid to the Commissioner of Police the sum of sixty dollars by way of removal charges, and a further sum of forty dollars for each day or part thereof during which the vehicle is kept in custody.

Charges payable before delivery of vehicle; and sale of vehicles in custody. [11 of 1963 20 of 1983 6 of 1993].

(2) Notwithstanding the provisions of subsection (1), where any vehicle is left in custody for any period exceeding thirty days any police officer not below the rank of superintendent may direct that such vehicle be sold by public auction and any moneys arising from the sale shall be applied in the following order:

- (a) in defraying the expenses of sale, if any;
 (b) in settlement of any sum payable by the owner under subsection (1); and
 (c) to the credit of the registered owner of the vehicle.

(3) At least fourteen days' notice shall be given in a daily newspaper of any sale by public auction of a motor vehicle under this section.

(4) Where a vehicle is sold under this section, the police officer who authorised the sale shall issue to the purchaser a certificate to that effect and such certificate shall be sufficient authority to the Licensing Authority to register the vehicle in the name of the purchaser; and any right, title or interest of the former registered owner in the vehicle shall be extinguished on the issue of such certificate.

(5) Any moneys received by the Commissioner of Police under subsection (1) shall be used in defraying any expenses incident on the removal or custody of the vehicle and the balance, if any, shall be paid to the Comptroller of Accounts.

In the event of a conflict of laws, the provisions of this Act to prevail.

110. (1) Whenever the provisions of this Act or of any Regulations made hereunder are in conflict with the provisions of any other law relating to the control of vehicles and road traffic the provisions of this Act and the Regulations made hereunder shall prevail.

Where similar powers are granted under this and any other law the Board shall decide as to the exercise of those powers.

(2) Whenever any powers conferred on the Licensing Authority or the Commissioner of Police under this Act are similar to powers conferred on a Municipal or Road Authority under any other law and there shall arise any conflict or dispute as to the exercise of such powers, the matter at issue shall be referred to the Trinidad Transport Board who shall decide which authority shall exercise such powers and the manner in which such powers shall be exercised. The decision of the Board shall be final and conclusive.

Highway Code.

111. (1) The Licensing Authority shall, as soon as may be after the 13th March 1948, prepare a Code (hereinafter referred to as the Highway Code) comprising such directions as appear to him to be proper for the guidance of persons using roads and may from time to time revise the Code by revoking, varying, amending or adding to the provisions thereof in such manner as he thinks fit.

(2) The Highway Code and any alterations proposed to be made in the provisions of the Code on any revision thereof shall, as soon as prepared by the Licensing Authority, be laid before Parliament and the Code or revised Code, as the case may be, shall not be issued until the Code or the proposed alterations have been approved by Parliament.

(3) Subject to the foregoing provisions of this section, the Licensing Authority shall cause the Code and every revised edition of the Code to be printed and issued to the public at a price to be fixed by the President.

(4) A failure on the part of any person to observe any provision of the Highway Code shall not of itself render that person liable to criminal proceedings of any kind, but any such failure may in any proceedings (whether civil or criminal, and including proceedings for an offence under this Act) be relied upon by any party to the proceedings as tending to establish or to negative any liability which is in question in those proceedings.

LAWS OF TRINIDAD AND TOBAGO

Section 89,
[31 of 1976
36 of 1976].

***FIRST SCHEDULE**

FEES AND DUTIES

(1)	}		
	}	<i>(Deleted by Act No. 9 of 1997).</i>	
			\$
(7)		Driving Permits—	
		(a) three-year permit... ..	200.00
		(b) one-year permit	15.00
		(c) persons who have attained the age of sixty-five years may renew their driving permits without charge	
(8)		Motor omnibus conductor's licence... ..	5.00
(9)		Registration of motor vehicle or trailer	50.00
(10)		Re-classification of registration of vehicle	50.00
(11)		Certified extract of entry in Register of Motor Vehicles other than on registration... ..	20.00
(12)		Any duplicate or copy of a licence or permit authorised or required to be issued	40.00
(13)		Examination of driver under section 53	100.00
(14)		Certificate of competency under section 53... ..	20.00
(15)		Annual inspection—	
		(a) of a trailer	150.00
		(b) of a motor vehicle (commercial)	150.00
(16)		Dealer's licence... ..	1,200.00
(17)		Provisional permit	20.00

* This Schedule has been amended by the following: GNs 197/1957; 2/1963; 21/1963; Act No. 36 of 1967; GN 2/1968; Act No. 15 of 1968; GNs 13/1974, 27/1974; Acts Nos. 31 of 1976, 19 of 1978 and 14 of 1979; 146/1982; 3/1983; 4/1985; 23/1985; and Acts Nos. 17 of 1986; 11 of 1988; 6 of 1993; 3 of 1994; 9 of 1997; 2 of 2002.

LAWS OF TRINIDAD AND TOBAGO

Motor Vehicles and Road Traffic

Chap. 48:50

87

	\$
(18) Amendment to Register (other than a transfer of registration of the change of possession of a motor vehicle)... ..	20.00
(19) Study guide booklet (including Highway Code) ...	15.00
(20) Permit to convey persons other than persons employed to load or unload goods, merchandise or other loads on goods vehicles, agricultural trailers or trailers for a period not exceeding six months... ..	50.00 per month or part thereof
(21) Application for a taxi (other than a maxi-taxi) ...	40.00
(22) Taxi-driver's licence/badge (renewable every three years)	20.00
(23) Duplicate licence/badge for taxi drivers under item (22)	20.00
(24) Certified extract of motor vehicle Inspector's report ...	20.00
25. (1) Registration of locally assembled motor vehicles using foreign parts—	
(a) motor vehicle with engine size not exceeding 1799 cc—\$20,000.00;	
(b) motor vehicle with engine size exceeding 1799 cc—\$30,000.00.	
(2) Sub-item (1) shall cease to have effect from 1st May 2003.	

- Note: (a) A vehicle licence or a Conductor's permit is annual and expires on the 31st December following the date of issue [section 33 and regulation 21(5)].
- (b) Provisional permits and driving permits of persons over 63 years of age expire one year from the date of issue or renewal; and the driving permit expires three years from the date of issue or renewal (section 58).
- (c) Proportionate licence duties are payable as provided in section 33.

Note: For the purposes of this Schedule an Estate Car or Station Wagon is not a Good Vehicle.

LAWS OF TRINIDAD AND TOBAGO

88

Chap. 48:50 *Motor Vehicles and Road Traffic*

Section 62.
[47 of 1956
146/1969].

SECOND SCHEDULE

SPEED LIMITS

Class or Description of Vehicle	Maximum Speed kilometres per hour	
	Outside a Built-up Area	Within a Built-up Area
(a) Tractor (except a goods vehicle or private motor car with or without trailer) 	35	20
(b) Motor omnibus... 	65	50
(c) Motor vehicles constructed to carry more than ten passengers... 	65	50
(d) Goods vehicle the licensed M.G.W. of which exceeds 2540 kilograms with or without trailer	65	50
(e) Goods vehicle the licensed M.G.W. of which does not exceed 2540 kilograms with trailer	65	50
(f) Private motor car with trailer 	65	50
(g) Any other motor vehicle... 	80	50

THIRD SCHEDULE

Section 67.
[3 of 1969].

**SCOPE OF EXPERIMENTAL TRAFFIC REGULATIONS
THAT MAY BE MADE BY
THE COMMISSIONER OF POLICE**

1. For prescribing the routes to be followed by all classes of traffic, or by any particular class or classes of traffic or vehicles, from one specified point to another, either generally or between any specified times.
2. For prescribing streets which are not to be used for traffic by vehicles, or by vehicles of any specified class or classes, either generally or at specified times.
3. For regulating the relative position in the roadway of traffic of differing speeds or types.
4. For prescribing the places where vehicles or vehicles of any particular class or description may not turn so as to face in the opposite direction to that in which they were proceeding, or where they may only so turn under conditions prescribed by the Regulations.
5. For prescribing the conditions subject to which, and the times at which, articles may be loaded on to or unloaded from vehicles, or vehicles of any particular class or description, on streets.
6. For prescribing the conditions subject to which, and the times at which, vehicles, or vehicles of any particular class or description, delivering or collecting goods or merchandise, or delivering goods or merchandise of any particular class or classes, may stand in streets, or in streets of any class or description, or in specified streets.
7. For prescribing rules as to precedence to be observed as between vehicles proceeding in the same direction, in opposite directions, or when crossing.
8. For prescribing places in streets where vehicles, or vehicles of any particular class or description, may, or may not, wait either generally or at particular times.
9. For prescribing cab ranks and ranks and stopping places of omnibuses and other public conveyances.

Section 14.

***FOURTH SCHEDULE**

Tax payable on registration of certain motor vehicles.

1. There shall be charged, levied and collected in respect of every motor vehicle of a class or description specified in the first column of Part I of Appendix A a tax (in this Act referred to as “motor vehicles tax”) calculated on such basis as is specified in the second column of that Part of Appendix A in relation to a motor vehicle of that class or description.

Payment of motor vehicles tax. [14 of 1979].

2. (1) Where motor vehicles tax is required to be paid on a motor vehicle, it shall be paid in the case of an imported motor vehicle by the importer of the vehicle and in the case of a locally assembled motor vehicle, by the assembler of the vehicle.

(2) Where a person who is required by this section to pay motor vehicles tax fails to do so, he is guilty of an offence and liable on conviction to a fine of one thousand dollars and to a further fine of one hundred dollars for each day that the motor vehicles tax remains unpaid after conviction.

Rebate of motor vehicles tax. [6 of 1977].

3. (1) Subject to this paragraph and to paragraphs 4 to 6 where motor vehicles tax has been paid on the sale of a private motor car, a taxi or a rented car (hereinafter referred to as a “motor car”) assembled in Trinidad and Tobago a rebate of tax shall be made to the manufacturer.

(2) For the purposes of subparagraph (1), motor vehicles tax shall be deemed to have been paid where the purchaser of the motor car was exempt from the payment of the tax or any part thereof or where the tax or any part thereof has been remitted.

(3) Subject to paragraph 7, the rebate of tax in respect of any such motor car shall be computed in accordance with Appendix B according to the local value added in the assembly of the motor car.

(4) Nothing in this paragraph shall apply in any case where the motor car is sold for export.

(5) In this paragraph and in paragraphs 5 and 6 “manufacturer” means a person who carries on in Trinidad and Tobago the business of assembling motor cars.

Local value added. [6 of 1977].

4. (1) In this paragraph, in paragraphs 3, 5 and 6 and in Appendix B and Appendix C, the local value added is the aggregate amount of the expenses specified in Appendix C incurred during the immediately preceding year in the assembly of motor cars similar to the motor cars in respect of which the claim for rebate of tax is made apportioned over the number of motor cars assembled during that year and expressed as a percentage of the showroom price of such motor car.

*This Schedule has been amended by the following: Act No. 35 of 1957; GN’s 115/1958, 2/1963, 21/1963, 27/1966, 6/1968, 2/1973, 11/1974, 6/1975; Acts Nos. 6 of 197, 28 of 1978, 14 of 1979, 2 of 1982, 146/1982, 3/1983, 157/1983; and Acts Nos. 9 of 1990; 3 of 1994 and 2 of 2002.

(2) Notwithstanding subparagraph (1) in any case where the Minister so directs the Board of Inland Revenue may reduce the aggregate amount of the expenses incurred in the assembly of any such motor cars by an amount representing the excess over the level of profits that the Minister considers appropriate to be taken into account in determining the local value added of any such motor cars.

(3) In any case where there is no immediately preceding financial year or the immediately preceding financial year is less than twelve months, the aggregate amount of expenses incurred in the assembly of similar motor cars in the current financial year shall be estimated in the claim for the rebate of tax and subject to subparagraph (4) be applied in determining the local value added.

(4) In any case where the aggregate amount of the expenses incurred in the assembly of similar motor cars is estimated under subparagraph (3), the Board of Inland Revenue shall as soon as it considers it convenient determine the twelve-month period to be taken as the immediately preceding financial year for the purpose of calculating the local value added with respect to any such motor cars for the first financial year.

(5) In this section “financial year” means the period of twelve months during which the business of a person is made up.

5. (1) The rebate of tax provided for in paragraph 3 shall be made monthly in arrear to a manufacturer upon a claim therefor.

Claim for rebate.
[6 of 1977].

(2) Every claim for rebate of tax in respect of any motor car shall contain the following information:

- (a) the make, chassis number, registration number, engine number (measured in cubic centimetres) and the showroom price of the motor car sold in the current financial year with respect to which the claim is made;
- (b) the make, chassis number, registration number, engine number (measured in cubic centimetres) and the showroom price of similar motor cars sold during the immediately preceding financial year;
- (c) the local value added showing additional particulars required for the calculation thereof, or the estimated local value added; and
- (d) the amount of motor vehicles tax paid in respect of the motor car, the date of payment and the name and address of the office into which payment of the motor vehicles tax has been paid.

6. The Board of Inland Revenue or any officer acting under its authority may examine the books of account of a manufacturer for the purpose of determining the local value added in the assembly of the motor car in respect of which the claim for rebate of tax is made.

Examination of books of account.
[6 of 1977].

LAWS OF TRINIDAD AND TOBAGO

92

Chap. 48:50 *Motor Vehicles and Road Traffic*

- Commencement dates. [6 of 1977].
7. (1) Subject to subparagraphs (2) and (4), paragraphs 3 to 6 and subparagraph (3) of this paragraph shall be deemed to have come into operation on 4th July 1973.
- Rate of rebate as from 1975.
- (2) The rate of rebate of tax provided in Appendix B shall have effect in respect of the financial year ending in 1975 and subsequent years.
- Rate of rebate until 1975.
- (3) Until the rate of rebate of tax provided in Appendix B takes effect in accordance with subparagraph (2), the rate of rebate of tax shall be as follows:
- (a) Where the local value added exceeds 30 per cent but does not exceed 40 per cent, the rebate shall be—
- (i) in the case of motor cars the showroom price of which is less than three thousand five hundred dollars, 15 per cent of the motor vehicles tax;
 - (ii) in the case of motor cars the showroom price of which is three thousand five hundred dollars or more but under five thousand dollars, 10 per cent of the motor vehicles tax;
 - (iii) in the case of motor cars the showroom price of which is five thousand dollars or more but under seven thousand dollars, 5 per cent of the motor vehicles tax.
- (b) Where the local value added exceeds 40 per cent, the rebate shall be—
- (i) in the case of motor cars the showroom price of which is less than three thousand five hundred dollars, 20 per cent of the motor vehicles tax;
 - (ii) in the case of motor cars the showroom price of which is three thousand five hundred dollars or more but under five thousand dollars, 15 per cent of the motor vehicles tax;
 - (iii) in the case of motor cars the showroom price of which is five thousand dollars or more but under seven thousand dollars, 10 per cent of the motor vehicles tax.
- Retrospective application to CARIFTA.
- 12 of 1968.
- (4) For the purposes of making rebate of tax during the period 1st January 1973 to 3rd July 1973, paragraphs 3, 4, 5 and 6 (together with Appendices B and C) shall be deemed to have come into operation on 1st January 1973 and shall be read and construed with such adaptations and modifications as are necessary or expedient, as if the Customs (Amendment) Act 1968 was still in force.

***APPENDIX A**

Paragraph 1.

In this Appendix—

- (a) engine size references expressed in cm³ means the total volume of the cylinders measured in cubic centimetres;
- (b) “showroom price” means such sum as in the opinion of the Board of Inland Revenue is the ordinary retail selling price of the motor vehicle without having regard to any discounts, commissions, monetary deductions, or other allowances given or made by the seller thereof.

PART I

PARTICULARS OF TAX

<i>Class of Description of Motor Vehicles</i>	<i>Vehicle Tax</i> \$
(1) Private motor cars or rented cars, station wagons or estate wagons:	
(a) Engine size exceeding 1599 cc but not exceeding 1799 cc	4.00 per cc
(b) Engine size exceeding 1799 cc but not exceeding 1999 cc	8.00 per cc
(c) Engine size exceeding 1999 cc but not exceeding 2499 cc	21.00 per cc
(d) Engine size exceeding 2499 cc but not exceeding 2999 cc	25.00 per cc
(e) Engine size exceeding 2999 cc but not exceeding 3499 cc	30.00 per cc
(f) Engine size exceeding 3499 cc	45.00 per cc

*This Appendix (Appendix A to the Fourth Schedule) has been amended by the following: Act No. 35 of 1957; GNs 115/1958, 2/1963, 21/1963, 27/1966, 6/1968, 2/1973, 11/1974, 6/1975; Acts Nos. 28 of 1978, 2 of 1982; 146/1982; 3/1983; 157/1983; and Acts Nos. 9 of 1990, 4 of 1992, 3 of 1994, 5 of 1995, 8 of 1996, 9 of 1997 and 2 of 2002.

PARTICULARS OF TAX—Continued

<i>Class of Description of Motor Vehicles—continued</i>	<i>Vehicle Tax</i> \$
(2) Taxis:	
(a) Engine size not exceeding 999 cc	0.75 per cc
(b) Engine size exceeding 999 cc but not exceeding 1499 cc	1.50 per cc
(c) Engine size exceeding 1499 cc but not exceeding 1799 cc	3.00 per cc
(d) Engine size exceeding 1799 cc but not exceeding 1999 cc	6.00 per cc
(e) Engine size exceeding 1999 cc but not exceeding 2499 cc	15.75 per cc
(f) Engine size exceeding 2499 cc but not exceeding 2999 cc	18.75 per cc
(g) Engine size exceeding 2999 cc but not exceeding 3499 cc	22.50 per cc
(h) Engine size exceeding 3499 cc	33.75 per cc
(3) Maxi-Taxis:	
(a) Engine size not exceeding 2499 cc... ..	6.00 per cc
(b) Engine size exceeding 2499 cc	8.00 per cc
(4) Goods Vehicles	2.50 per cc
(5) Tractors	
(a) Agricultural tractors	1.00 per cc
(b) Industrial tractors	1.00 per cc
(6) Completely built-up foreign used motor vehicles imported by persons other than returning nationals, seventy-five per cent of the tax specified in subparagraph (1), (2), (3) or (4).	

Note—For the purposes of this Part of this Schedule, a station wagon or estate vehicle is not a goods vehicle.

PART II

[28 of 1978].

RELIEF FOR CITIZENS RETURNING FROM ABROAD

1. (a) A returning national of Trinidad and Tobago who returns to Trinidad and Tobago to reside permanently after residing abroad for a continuous period of not less than five years shall, where he imports a motor vehicle of a class or description set out at item 1(1) in Part I of this Appendix, be entitled to relief from motor vehicles tax as follows:

- (i) where he is the registered owner of the vehicle for more than six months but not more than one year, 25 per cent of the tax payable;
- (ii) where he is the registered owner of the vehicle for more than one year but not more than two years, 50 per cent of the tax payable;
- (iii) where he is the registered owner of the vehicle for more than two years, 90 per cent of the tax payable,

except that where there is a transfer of ownership of the motor vehicle within two years of the date of its importation into Trinidad and Tobago, there shall become immediately due and payable by the transferor, motor vehicles tax in an amount equal to the amount of relief granted.

(b) A person seeking relief from motor vehicles tax shall satisfy the Board of Inland Revenue—

- (i) that he is the registered owner of the motor vehicle in respect of which he is required to pay motor vehicles tax;
- (ii) that he acquired the motor vehicle while abroad and was the owner of that vehicle for the entire period on which his claim for relief from motor vehicles tax is based.

2. A returning national who imports a motor vehicle into Trinidad and Tobago shall, upon satisfying the relevant conditions stipulated in section 45A of the Customs Act, be entitled to exemption from motor vehicles tax in respect of the motor vehicle. Ch. 78:01.

Paragraph 4(1).
[6 of 1977].

APPENDIX B

RATE OF REBATE OF MOTOR VEHICLES TAX

Rate of rebate as
from 1975.

- (1) Where the local value added is 35 per cent or more but does not exceed 45 per cent the rebate shall be—
- (a) in the case of motor cars with an engine rating of under 1,500 cm³, 15 per cent of the motor vehicles tax;
 - (b) in the case of motor cars with an engine rating of 1,500 cm³ and over but under 1,800 cm³, 10 per cent of the motor vehicles tax;
 - (c) in the case of motor cars with an engine rating of 1,800 cm³ and over but under 2,500 cm³, 5 per cent of the motor vehicles tax.
- (2) Where the local value added exceeds 45 per cent the rebate shall be—
- (a) in the case of motor cars with an engine rating of under 1,500 cm³, 20 per cent of the motor vehicles tax;
 - (b) in the case of motor cars with an engine rating of 1,500 cm³ and over but under 1,800 cm³, 15 per cent of the motor vehicles tax;
 - (c) in the case of motor cars with an engine rating of 1,800 cm³ and over but under 2,500 cm³, 10 per cent of the motor vehicles tax.

Paragraph 4(1).
[6 of 1977].

APPENDIX C

EXPENSES FOR DETERMINING LOCAL VALUE ADDED

1. The expenses to be computed in determining the local value added are as follows:
- (a) wages and other earnings of wage labour paid, excluding overtime earnings, and wages and other earnings of wage labour paid to non-nationals;
 - (b) salaries and other earnings of salaried staff and management fees paid, not including salaries and other earnings of salaried staff and management fees paid to non-nationals and to non-resident principals of resident companies;
 - (c) any interest paid, not being interest paid to non-nationals and to non-resident principals of resident companies;

- (d) normal depreciation on physical assets, other than imported assets, as shown in the books of account;
- (e) payments for patents, royalties, licences and similar charges, not including payments for patents, royalties, licences and similar charges made to non-nationals and to non-resident principals of resident companies;
- (f) rent paid, not including rent paid to non-nationals and to non-resident principals of resident companies;
- (g) the cost of raw materials (including components and fuel power) other than imported raw materials, used in productions;
- (h) other overhead expenses apportionable to production, not including similar expenses incurred to non-nationals and to non-resident principals of resident companies; and
- (i) plant profit, not including profits distributed or remitted directly or indirectly to non-nationals and to non-resident principals of resident companies.

2. In this Appendix—

“Caribbean Common Market”, “Common Market Origin” and “Member State” have the same meanings respectively as in the Customs Act;

Ch. 78:01.

“imported” means imported from outside the Caribbean Common Market or imported from the Caribbean Common Market but not qualifying for treatment as goods of Common Market Origin;

“non-national” means a person who is not a citizen of a Member State and includes a person whose connection with such a State does not entitle him to be regarded as belonging to, or being a native or resident of the State for the purposes of the laws relating to immigration for the time being in force;

“non-resident-principal” means a person (including a company) who is not resident in a Member State;

“resident company” means a company incorporated in a Member State and not controlled directly or indirectly by a person (including a company) who is not resident in a Member State.

LAWS OF TRINIDAD AND TOBAGO

98

Chap. 48:50 *Motor Vehicles and Road Traffic*

(Section 19A).
[3 of 1994].

FIFTH SCHEDULE

PARTICULARS OF MOTOR VEHICLES TRANSFER TAX

	\$	¢
(a) Used motor vehicles (other than motorcycles) over ten years old	100.00	
(b) Used motor vehicles (other than motorcycles) over seven years old, but not more than ten years old ...	900.00	
(c) Used motor vehicles (other than motorcycles) over five years old but not more than seven years ...	2,000.00	
(d) Used motor vehicles (other than motorcycles) over two years old but not more than five years old ...	3,000.00	
(e) Used motor vehicles (other than motorcycles) two years old and under	4,000.00	
(f) Used motorcycles not exceeding 250 cc	100.00	
(g) Used motorcycles exceeding 250 cc	200.00.	

NOTE ON TRANSITIONAL PROVISIONS

The Amendment Act 14 of 1979 contained the following transitional provisions:

17. (1) Subject to *section 31, upon the commencement of this Act—
- (a) a person who is the holder of a learner's permit, may continue to use that permit until it expires or until he becomes entitled to be issued a driver's permit whichever happens first;
 - (b) a person who is the holder of a driving permit to drive a private motor car, is permitted to drive a Class 3 motor vehicle, save that in order to drive a taxi he is required to have in addition to the driving permit a taxi driver's licence and badge;
 - (c) a person who is the holder of a driving permit to drive a heavy goods vehicle, is permitted to drive a Class 4 motor vehicle.

(2) A person who immediately before the commencement of this Act was the holder of a permit to drive a heavy goods vehicle and who during the currency of that permit used to drive any vehicle which under this Act is a Class 5 vehicle may continue to drive such a vehicle for a period not exceeding six months from the commencement of this Act, and shall upon production to the Transport Commissioner within that period, of satisfactory evidence of the fact of his driving such a vehicle, be issued the appropriate driving permit under this Act.

(3) Where a person referred to in subsection (2) fails to produce satisfactory evidence as required by that subsection, he shall be required to take and pass a driving test in order to be issued a driving permit for a class 5 motor vehicle.

* That is, section 31 now (section 48) of this Act. Act 14 of 1979 came into operation on 1st May 1979.

SUBSIDIARY LEGISLATION

MOTOR VEHICLES AND ROAD TRAFFIC REGULATIONS

ARRANGEMENT OF REGULATIONS

REGULATION

PART I

GENERAL

1. Citation.
2. Interpretation.
3. Forms, as in First Schedule.

PART II

REGISTRATION

4. Application by owner for registration.
5. Number to be assigned.
6. When Licensing Authority may cancel registration.
7. Identification mark.
8. Use for registered purpose only.
9. Position of identification mark.
10. Illumination of identification mark at night.
11. General identification marks for dealer.
12. Record Book.

PART III

LICENSING

13. *(Revoked by Act No. 9 of 1997).*
14. Weighing of vehicles.
15. } *(Repealed by Act No. 9 of 1997).*
16. }
17. Number of persons to be carried.

PART IV

DRIVING AND CONDUCTOR'S PERMITS

18. Application for permit.
19. Form of driving permit or provisional permit.
20. Application for renewal prior to date of expiration.
- 20A. Application for renewal where applicant will be absent from country.

REGULATION

21. Conductor's permit.
22. Badges for conductors.
23. Re-issue of lost or defaced permit or badge.
24. Cancellation or suspension of conductor's permit.
25. Cancellation or suspension of driver's permit.
26. Medical certificate.

PART V

INSPECTION OF MOTOR VEHICLES

27. Inspection of motor vehicles, etc., and register.

***PART VA**

AUTHORISED EXAMINERS AND PREMISES

- 27A. Applications for authorisations.
- 27B. Authorisations.
- 27C. Conditions to be complied with by proprietors.
- 27D. Termination of authorisation.
- 27E. Forms and documents to be returned to Transport Commissioner.
- 27F. Application for examination.
- 27G. Requirements as to vehicles submitted for examination.
- 27H. Conditions as to responsibility for damage to vehicles and third party.
- 27I. Results of examinations.
- 27J. Refusal of a test certificate where braking test cannot be carried out.
- 27K. Removal of vehicles submitted for examination.
- 27L. Appeal on refusal of a test certificate.
- 27M. Payment to proprietors at whose premises examinations on appeals are carried out.
- 27N. Fees for examination.
- 27O. Fees on appeals.
- 27P. Records to be kept and returns to be furnished by proprietors.
28. Conditions of use of motor vehicles on public road.
 - Reversing.
 - Width.
 - Length.
 - Overhang.
 - Distribution of weight.

LAWS OF TRINIDAD AND TOBAGO

102

Chap. 48:50

Motor Vehicles and Road Traffic

[Subsidiary]

Motor Vehicles and Road Traffic Regulations

ARRANGEMENT OF REGULATIONS—*Continued*

REGULATION

- Brakes.
- Trailers.
- Weight shown in certain cases.
- Condition of vehicle.
- Silencers.
- Cut-outs.
- Unauthorised lights.
- Unauthorised letters and figures.
- Lights.
- 29. Stationary motor vehicle.
- 30. Direction indicators.
- 31. Left-hand driven vehicles.

PART VI

INSPECTION OF VEHICLES OTHER
THAN MOTOR VEHICLES

- 32. Definition.
- 33. Bells, etc.
- 34. Lights on vehicles other than motor vehicles.
- 35. Cycle brakes.
- 36. Constable may test cycle brakes.
- 37. Liability of parents and guardians.

PART VII

USE OF MOTOR VEHICLES

- 38. Rules to be observed by drivers.
 - Travelling backwards.
 - Full control and view to be maintained.
 - Brakes to be applied and engine stopped on quitting motor vehicle.
 - Restrictions as to sitting by driver.
 - To keep to the left.
 - To keep on the left on meeting other traffic.
 - Overtaking.
 - Being overtaken.
 - Cutting in.
 - Corners.
 - Crossings.

REGULATION

- Turning to left.
- Turning to right.
- Stopping at corners.
- Drawing up alongside other motor vehicles.
- Drawing up and standing alongside of fire hydrant.
- Obstruction.
- Turnings and crossroads.
- Traffic signals.
- Traffic directions.
- Slow moving traffic.
- Drawing up at side of road.
- Horns, etc.
- Sparks, smoke, vapour, lubricating oil.
- Stopping of motor vehicle at request of constable, or person in charge of horse.
- Projections.
- Overcrowding.
- Riding outside.
- Motor vehicles unattended.
- Passage of Fire Brigade.
- Towing other vehicles.
- Length of tow rope.
- 39. Filling petrol into motor vehicles.
- 40. Reflecting mirror.
- 41. Fittings and equipment to be properly adjusted.
- 42. Load to be properly secured.
- 43. Noisy motor vehicles.
- 44. Tyres.
- 45. Safety glass windshield.
- 46. Windshield wiper.
- 47. Traffic signal.
- 48. Cyclists and pedestrians to comply with traffic control signal.
- 49. Prohibition on playing of musical or noisy instruments in a motor vehicle.

LAWS OF TRINIDAD AND TOBAGO

104

Chap. 48:50

Motor Vehicles and Road Traffic

[Subsidiary]

Motor Vehicles and Road Traffic Regulations

ARRANGEMENT OF REGULATIONS—*Continued*

REGULATION

PART VIII

**USE OF VEHICLES OTHER THAN
MOTOR VEHICLES AND OF ANIMALS**

50. Application of certain provisions of Part VII to drivers and riders of vehicles other than motor vehicles, and of animals.
51. Traffic signals.
52. Reckless driving.
53. Careless driving.
54. Driving or riding while under influence of drink.
55. Control of animal drawing vehicle.
56. Control of cattle.
57. Driving or riding on the footpath.

PART IX

**PUBLIC SERVICE VEHICLES—
CONSTRUCTION AND MAINTENANCE**

MOTOR OMNIBUSES

58. Body and chassis.
59. Curtains, screens, etc., to be properly fastened.
60. Flooring.
Fittings for motor omnibuses.
61. Seats, corridor and safety exits.
62. Steps, etc.
63. Toeguards.
64. Driver's seat.
65. Conductor's seat.
66. Motor omnibus to carry conductor.
67. Front protection.
68. Internal height.
69. Driver's uniform and badge.
70. Special regulations for motor bus conductors.
71. Motor bus to proceed direct to destination.
72. Entering or leaving bus.

LAWS OF TRINIDAD AND TOBAGO

REGULATION

- 73. Licensing Authority may delegate his powers.
- 74. Motor omnibuses registered prior to 1st January 1935.
- 75. Saving as to motor omnibus.

PUBLIC SERVICE VEHICLES

- 76. Special regulations for drivers of public service vehicles.
- 77. Lost property.
- 78. Touting.
- 79. Attire of taxi driver.
- 80. Advertisement.
- 81. Refusal to hire motor vehicle.
- 82. *(Repealed by LN 197/1999).*
- 83. *(Deleted by LN 34/2003).*
- 84. Right to demand fare.

PART X

RESTRICTIONS RELATING TO MOTOR OMNIBUSES

- 85. Omnibus routes.
- 86. Routes to be specified on licence.
- 87. Special permits.
- 88. } *(Repealed by LN 197/1999).*
- 89. }
- 90. }
- 91. Reconsideration of Licensing Authority's decision.

PART XI

RULES FOR PARKING OF VEHICLES

- 92. No lighted lamps on motor vehicles required when in parking places and public stands.
- 93. Rules for parking of taxis.
- 94. Taxis leaving stands.
- 95. Parking of taxis.
- 96. Alignment of omnibuses.

LAWS OF TRINIDAD AND TOBAGO

106

Chap. 48:50

Motor Vehicles and Road Traffic

[Subsidiary]

Motor Vehicles and Road Traffic Regulations

ARRANGEMENT OF REGULATIONS—*Continued*

REGULATION

- 97. Omnibuses leaving stands.
- 98. Parking.
- 99. } *(Repealed by LN 197/1999).*
- 100. }

PART XII

TRAFFIC LIGHT SIGNALS

- 101. Licensing Authority to erect and maintain light signals.
- 102. Significance of light signals.
- 103. *(Repealed by LN 197/1999).*
- 104. “Cross” and “Don’t Cross” Signals.
- 104A. Inoperative traffic lights.

PART XIII

SPECIAL TRAFFIC DIRECTIONS

- 105. Traffic at dual carriageways.
- 106. Traffic at roundabouts.
- 107. Traffic at crossroads.
- 108. *(Repealed by LN 197/1999).*
- 109. Restricting lorries on part of High Street.
- 110. Parking of vehicles in San Fernando.

PART XIV

TAXIS

- 111. Taxi Drivers’ licences.
- 112. Duplicate licences.
- 113. Cancellation of Taxi Drivers’ licences.
- 114. Changes in particulars set out in taxi drivers’ licences to be notified.
- 115. Production and inspection of taxi drivers’ licences.
- 116. Only *bona fide* passengers to be in taxis plying for or on hire in taxi stands.
No person to loiter on or about a taxi stand.

LAWS OF TRINIDAD AND TOBAGO

Motor Vehicles and Road Traffic

Chap. 48:50

107

Motor Vehicles and Road Traffic Regulations

[Subsidiary]

REGULATION

- 117. Taxi not to be used for indecent or immoral purpose.
- 118. *(Repealed by LN 197/1999).*
- 119. Exemption.
- 120. Rented cars not to be used as taxis.

PART XV

MISCELLANEOUS

- 121. Limitation of drivers' working hours.
- 122. Discretionary powers of Licensing Authority.
- 123. Eastern Main Road Regulations.
- 124. Eastern Main Road, Demerara Road, Aripo and Heights of Guanapo Roads.
- 125. Western Main Road.
- 126. Chaguanas Road.
- 127. Liability for contravention or failure to comply with Regulations.

FIRST SCHEDULE.

SECOND SCHEDULE.

THIRD SCHEDULE.

FOURTH SCHEDULE.

FIFTH SCHEDULE.

SIXTH SCHEDULE.

SEVENTH SCHEDULE.

[Subsidiary]

G. 1.6.44.

***MOTOR VEHICLES AND ROAD TRAFFIC
REGULATIONS**

made under section 100

PART I

GENERAL

Citation.

1. These Regulations may be cited as the Motor Vehicles and Road Traffic Regulations.

Interpretation.
[177/1956
39/1957
151/1971
197/1999].

2. In these Regulations—

“at night” means from half an hour after sunset until half an hour before sunrise, or such other period for the lighting of vehicles as shall be fixed from time to time by the Commissioner of Police and published in the *Gazette*;

Ch. 25:04.

“Borough of Arima” means the Borough of Arima as defined in the First Schedule to the Municipal Corporations Act;

“Borough of Chaguanas” means the Borough of Chaguanas as defined in the First Schedule to the Municipal Corporations Act;

“Borough of Point Fortin” means the Borough of Point Fortin as defined in the First Schedule to the Municipal Corporations Act;

“centre line” means any line printed on, or made of metal or any other suitable material placed on, in or near the centre of a road for the purpose of dividing the directions in which traffic must flow or the lanes of traffic flowing in the same direction;

“City of Port-of-Spain” means the City of Port-of-Spain as defined in the First Schedule to the Municipal Corporations Act;

*These Regulations were amended by the following: GNs 200/1951, 233/1951, 83/1952, 71/1953, 177/1956, 26/1957, 27/1957, 39/1957, 43/1958, 124/1958, 148/1958, 94/1959, 125/1959, 108/1960, 88/1961, 11 of 1963, 32/1964, 32 of 1964, 21/1966, 73/1966, 105/1970, 57/1971, 86/1971, 151/1971, 105/1972, 15/1977, 27/1979, 61/1979, 72/1979; 206/1979, 207/1979, 208/1979, 211/1979; 104/1982; 6 of 1993; 9 of 1997; 197/1999; (See Act No. 9 of 2001); 34/2003.

These Regulations, though made under section 100, are published first because of their importance and because it avoids the inconvenience of separating certain of the Orders from the others.

LAWS OF TRINIDAD AND TOBAGO

Motor Vehicles and Road Traffic

Chap. 48:50

109

Motor Vehicles and Road Traffic Regulations

[Subsidiary]

“City of San Fernando” means the City of San Fernando as defined in the First Schedule to the Municipal Corporations Act; Ch. 25:04.

“cycle” means a pedal bicycle or pedal tricycle, not being in either case a mechanically propelled vehicle;

“identification mark” means the index mark and the separate number referred to in regulation 7(1)(a)(i);

“lateral overhang” means the distance measured from the outer face of the tyre on the rear wheel on the same side of the vehicle (and in the case of dual tyres from the outer face of the outer tyre) to a vertical line let fall from the extreme limit of the body;

“longitudinal overhang” means the distance measured from the centre of a hub of a rear wheel to a vertical line let fall from the extreme limit of the body;

“Municipal area” means the City of Port-of-Spain, the City of San Fernando, the Borough of Arima, the Borough of Chaguanas and the Borough of Point Fortin;

“overall length” in relation to a single vehicle means the length of the vehicle exclusive of the starting handle, if any, and of the hood, if any, when down, or, in the case of a trailer, the draw-bar, measured between parallel planes passing through the extreme projecting points of the vehicle, and, in relation to a combination of vehicles, the length measured between parallel planes passing through the extreme forward projecting point of the tractor and the extreme rear projecting point of the last trailer being towed;

“overall width” means the width measured between parallel lines passing through the extreme projecting points of the vehicle exclusive of any driving mirror or of any direction indicator when in operation, and of so much of the distortion of any tyre as is caused by the weight of the vehicle;

LAWS OF TRINIDAD AND TOBAGO

110

Chap. 48:50 *Motor Vehicles and Road Traffic*

[Subsidiary]

Motor Vehicles and Road Traffic Regulations

“overcrowding” means more persons that will allow the driver to operate his vehicle freely without interference, and safely; that is, if his movement as they affect the gear shift lever, the brakes, the clutch, the steering wheel, is interfered with, or if his vision is obstructed so that he cannot safely drive or operate his vehicle;

“public stand” means an appointed place where public service vehicles or any particular class of public service vehicles may wait;

“schedule” means a schedule to these Regulations;

“stopline” means any line painted on, or made of metal or other suitable material placed on, a road for indicating where traffic must stop when required to do so either by a constable engaged in the control of traffic or by a traffic sign or by a light signal.

Forms, as in First Schedule.

3. For the purposes of the Act the forms set out in the First Schedule, or forms to the like effect, may be used in the cases to which they refer, with such variation as the Licensing Authority may consider desirable.

PART II

REGISTRATION

Application by owner for registration. (Form 1).

First Schedule.

4. The owner of a motor vehicle or trailer who desires to register it shall apply to the Licensing Authority and shall furnish him with the particulars set out in the form of application in the First Schedule.

Number to be assigned.

5. On receipt of any such application, with the particulars and the fee of ten dollars, the Licensing Authority shall, subject to the provisions of the Act, assign a separate number to the motor vehicle or trailer and register it by making the required entries in the register. On the registration of a motor vehicle or trailer, the Licensing Authority shall furnish the owner thereof with a certified copy of the entry.

When Licensing Authority may cancel registration.

6. If the Licensing Authority is satisfied that a motor vehicle or trailer which has been registered is destroyed, broken up or permanently removed from Trinidad and Tobago, he may cause the entries in the register with respect to that motor vehicle or

trailer to be cancelled, and may, if he thinks fit, assign the registered number of the motor vehicle or trailer to any other motor vehicle or trailer.

7. (1) The identification mark to be carried by a registered motor vehicle or trailer in pursuance of section 12 of the Act, shall consist of two plates which must conform as to size, lettering, numbering and otherwise with the following provisions:

Identification
mark.
[151/1971
27/1979
72/1979
9 of 1997].

- (a) (i) each plate must be rectangular and bear upon it the index mark of “P” for private motor vehicles, “T” for goods vehicles, “R” for rented cars, “H” for public service vehicles, “X” for any other vehicle and the separate number assigned to the motor vehicle by the Licensing Authority; but when the number 9999 shall have been assigned, the Licensing Authority may thereafter from time to time reassign the numbers 1–9999 in series, each series having a letter of the alphabet prefixed to the number;
- (ii) the mark and number shall be arranged in conformity with the arrangement of letters and figures shown on one or other of the alternative diagrams in the Second Schedule: Provided that as regards numbers re-assigned in series the letter of designation shall be prefixed as mentioned in subparagraph (i);
- (b) the two plates may, at the option of the owner, be of either of the shapes shown in the alternative diagrams in the Second Schedule or one of one shape and one of the other;
- (c) (i) the identification mark shall be formed of white letters and figures on a black surface, and every letter or figure shall be indelibly inscribed or so attached to such surface that it cannot readily be detached therefrom;

Second
Schedule.

- (ii) the identification mark may, at the option of the owner, be constructed and used in a manner which illuminates it by reflection, transparency, translucency or otherwise. If the identification mark is so constructed and used, the letters and figures shall be black on a white surface, and every letter or figure shall be indelibly inscribed or so attached to such surface that it cannot readily be detached therefrom;
- (d) all letters and figures must be eighty-five millimetres high; every part of every letter and figure must be fifteen millimetres broad; and the total width of the space taken by every letter or figure, except in the case of the figure 1, must be sixty millimetres;
- (e) (i) subject to subparagraph (ii), the space between adjoining letters and between adjoining figures on each plate shall be ten millimetres, and there shall be a margin between the nearest part of any letter or figure and the top and bottom of the plate of at least ten millimetres, and between the nearest part of any letter or figure and the sides of the plate of at least twenty-five millimetres;
- (ii) where a registration number comprises three letters and four figures the space between adjoining letters and between adjoining figures on each plate shall be eight millimetres, and there shall be a margin between the nearest part of any letter or figure and the top and bottom of the plate of at least ten millimetres, and between the nearest part of any letter or figure and the sides of the plate of at least fifteen millimetres;

- (f) in the alternative diagram No. 1, the space between the upper and lower lines must be fifteen millimetres. In the alternative diagram No. 2, the space between the letter and the figures must be thirty-five millimetres.

(2) Letters and numbers as prescribed in the Second Schedule painted on or otherwise fixed to the motor vehicle or trailer, may be used instead of plates. Any reference to plates in these Regulations shall be construed to include a reference to numbers and letters so painted or fixed, and any reference to the fixing of plates to include a reference to the numbers and letters so painted or fixed or other delineation of the numbers and figures.

8. No person shall use a motor vehicle for a purpose other than that for which it is registered.

9. The plates forming the identification mark shall be fixed, one on the front and the other on the back of the motor vehicle or trailer, in an upright position, so that every letter or figure on the plate is upright and easily distinguishable, in the case of the plate placed on the front of the motor vehicle or trailer from in front of the motor vehicle or trailer, and in the case of the plate placed on the back, from behind the motor vehicle or trailer.

In the case of a motor cycle, the plate fixed on the front of the cycle may, if it is a plate having duplicate faces conforming with the Second Schedule be fixed so that from whichever side the cycle is viewed the letters or figures on one or other face of the plate are easily distinguishable, though they may not be distinguishable from the front of the cycle.

Subject to the provisions of this regulation, the plates forming the identification mark shall be fixed on the motor vehicle or trailer in the position indicated in the particulars given in the application for the registration of the motor vehicle or trailer or subsequently furnished to the Licensing Authority or if he is not satisfied with the position so indicated, in such a position as he directs.

LAWS OF TRINIDAD AND TOBAGO

114

Chap. 48:50 *Motor Vehicles and Road Traffic*

[Subsidiary]

Motor Vehicles and Road Traffic Regulations

No motor vehicle shall be used on any road unless the plates forming the identification mark are clean and maintained in such condition as to render each letter or figure readily distinguishable.

Illumination of identification mark at night.

10. Whenever a motor vehicle or trailer is used on a public road at night a lamp shall be kept burning on the motor vehicle, or trailer so contrived as to illuminate by means of reflection, transparency or otherwise, and render easily distinguishable, every letter or figure on the identification plate fixed on the back of the motor vehicle or trailer.

In the application of this regulation to a motorcycle, the plate fixed on the front of the cycle may, if desired, be substituted for the plate fixed on the back of the cycle.

General identification marks for dealer. [197/1999].

11. (1) The Licensing Authority may assign to the holder of a dealer's general licence such number of general identification marks as he thinks fit. The marks shall be such as the Licensing Authority directs in each case—

Provided that—

- (a) they shall consist of two plates, each bearing some distinguishing letter or letters, and each having placed thereon or annexed thereto some distinguishing number; and
- (b) the colouring of the plates shall be different from that used for the plates forming the ordinary identification mark; and
- (c) the lettering and numbering of the plates shall, so far as possible, be similar to those required in the case of the plates forming the ordinary identification mark.

(2) Every holder of a dealer's general licence to whom general identification marks have been assigned shall keep a Demonstration Book, and on every occasion on which such

identification mark is used on a motor vehicle, he shall make or cause to be made in the Demonstration Book an immediate entry of the following particulars:

Date.

Identification mark.

Description of motor vehicle on which used.

Driver's name.

Time of departure from garage.

Time of return to garage.

Purpose for which the motor vehicle is used.

(3) The provisions of these Regulations which relate to the fixing and illumination of identification plates shall apply to the plates forming the general identification mark as they apply to the plates forming the ordinary identification mark.

(4) A motor vehicle used under the authority of a dealer's general licence shall not be used for any purposes other than those specified in section 35 of the Act and shall not be used for private or trade purposes either by the dealer or by any other person.

(5) Every holder of a dealers' licence shall not operate under the authority of such licence between the hours of 8.00 p.m. and 5.00 a.m. without the express written permission of the Licensing Authority.

12. Every owner of a rented car shall keep a record book and on every occasion on which such car is hired out he shall make or cause to be made in such record book an immediate entry of the following particulars:

Date.

Identification mark of rented car.

Hirer's name and address.

Time vehicle is hired out.

Period for which vehicle is hired out.

Time and date vehicle is returned.

Record Book.

LAWS OF TRINIDAD AND TOBAGO

PART III

LICENSING

(This Heading is deleted by Act No. 9 of 1997)

13. (Revoked by Act No. 9 of 1997).

Weighing of vehicles. [71/1953 6 of 1993 9 of 1997 197/1999].

14. The weighing of vehicles may be done at the weighbridges and portable scales maintained by the Licensing Authority, who is hereby authorised to charge therefor the following fees:

- (a) for the weighing of any vehicle for registration—twenty dollars;
- (b) for the weighing of any vehicle (with or without load) for other purposes—fifty cents per tonne or part thereof.

15. }
16. } (Repealed by Act No. 9 of 1997).

Number of persons to be carried. [9 of 1997].

17. The owner of every public service vehicle shall keep distinctly painted on the outside of such vehicle the number of persons which, under the terms of its registration, may be carried in such vehicle. Such number shall be painted in conspicuous figures and shall ordinarily be placed in the following positions:

- (a) in the case of a taxi, on the outside of the right front door;
- (b) in the case of a motor omnibus, on the outside of the driver’s seat.

PART IV

DRIVING AND CONDUCTOR’S PERMITS

Application for permit. [61/1979]. Form 4. First Schedule.

18. Applications for the issue or renewal of a driving permit or a provisional permit shall be made in the form set out as Form 4 in the First Schedule.

Form of driving permit or provisional permit. [61/1979]. Form 5A. Form 5B. First Schedule.

19. A driving permit shall be in the form set out as Form 5A in the First Schedule and a provisional permit shall be in the form set out as Form 5B in that Schedule.

20. Application for the grant or renewal of a driving permit may be received and dealt with at any time within one month before the date on which the renewal of the driving permit is to take effect.

Application for renewal prior to date of expiration.

20A. The Licensing Authority may receive and deal with applications for the renewal of a driving permit within six months before its date of expiration once it is proved to the Authority's satisfaction that the applicant will be absent from the country at the time of expiration of his permit.

Application for renewal where applicant will be absent from country. [197/1999].

21. (1) A person shall not act as a conductor of a motor omnibus unless he is the holder of a permit authorising him for the purpose; and no person shall employ any person who is not so authorised to act as such.

Conductor's permit. [15/1977 197/1999].

(2) A person who desires to obtain the grant or renewal of a permit as a conductor of a motor omnibus shall apply to the Licensing Authority and shall furnish him with the particulars set out in the form in the First Schedule.

Form 6. First Schedule.

(3) Every applicant for a permit as a conductor of a motor omnibus shall satisfy the Licensing Authority that—

- (a) he is above the age of eighteen years and is physically and mentally fit;
- (b) he is of good character;
- (c) he has sufficient knowledge of the rules of the road and of the Motor Vehicles and Road Traffic Regulations.

(4) The Licensing Authority on being satisfied as above shall grant a permit to the applicant on payment of a prescribed fee.

(5) The permit shall be in such form as may be approved by the Licensing Authority and shall have attached thereto a photograph of the applicant, such photograph being supplied in duplicate by the applicant when applying for the permit. The permit shall commence on the day on which the same is granted and shall expire on 31st December next following.

LAWS OF TRINIDAD AND TOBAGO

118

Chap. 48:50 *Motor Vehicles and Road Traffic*

[Subsidiary]

Motor Vehicles and Road Traffic Regulations

(6) Every conductor shall, on being so required by any constable in uniform, produce his permit for examination so as to enable such constable to ascertain the name and address of the holder of the permit, the date of issue and the Police Officer or Transport Officer in uniform by whom it was issued, and if he fails to do so, he shall be guilty of an offence under this regulation:

Provided that, if within forty-eight hours after the production of his permit was so required, the holder produces the permit in person at such Police Station as may be specified by him at the time its production was required, he shall not be convicted for such offence.

Badges for
conductors.
[197/1999].

22. On the grant of a permit to a driver or conductor of a motor omnibus a badge upon which there shall be marked the word “driver” or “conductor”, respectively, and the year of issue, shall be delivered to such person. Such badge shall be worn at all times when the driver or conductor is on duty in such a manner as to be easily seen.

Re-issue of lost
or defaced
permit or badge.
[197/1999].

23. If a person to whom any permit or badge has been granted by the Licensing Authority satisfies the Licensing Authority that his permit or badge has been lost or defaced, the Licensing Authority shall on payment of a prescribed fee issue to him a duplicate of such permit or badge.

Cancellation or
suspension of
conductor’s
permit.

24. The Licensing Authority may cancel or suspend the permit of any conductor on any conviction or contravention of the Act or of these Regulations or on being satisfied that he is not a fit and proper person to hold a conductor’s licence.

Cancellation or
suspension of
driver’s permit.
[197/1999].

25. (1) If it appears to the Transport Officer that there is reason to believe that any person who holds a driver’s permit is suffering from a disease or physical disability likely to cause the driving by him of a motor vehicle being a vehicle of any such class or description as he is authorised by the permit to drive, to be a source of danger to the public and, on enquiring into the matter, the Transport Officer is satisfied that the holder of the permit is suffering from such a disease or disability as aforesaid, then whether or not the holder of the permit so suffering as aforesaid has

previously passed a driving test, the Transport Officer may, after giving to the holder of the permit notice of his intention to do so, revoke the permit, and the holder shall on receipt of such notice deliver the permit to the Transport Officer for cancellation.

(2) If any person is aggrieved by the revocation of a driving permit under this regulation, he may, after giving notice to the Transport Officer of his intention to do so, appeal to the Licensing Authority, and on any such appeal the Licensing Authority may confirm or revoke the decision of the Transport Officer.

(3) If it appears to the Licensing Authority that a driving permit has been obtained through misrepresentation or has been issued to a person under a wrong name or under an assumed name by which he is not generally known, the Licensing Authority may, after giving to the holder of the permit notice of his intention to do so, revoke the permit, and the holder shall, on receipt of such notice, deliver the permit to the Licensing Authority for cancellation.

26. Where a person is required by the Act or the Regulations to submit a medical certificate to the Transport Officer, that medical certificate shall be in the form set out as Form 12 in the First Schedule.

Medical certificate.
[61/1979
197/1999].
Form 12.
First Schedule.

PART V

INSPECTION OF MOTOR VEHICLES

27. (1) A registered owner of a public service motor vehicle, rental car, goods vehicle, omnibus, tractor or trailer shall produce it for inspection by a Transport Officer, annually as the Licensing Authority may direct and shall, at the same time, furnish him with such information as may be required including the following:

Inspection of motor vehicles, etc., and register.
[197/1999
34/2003].

- (a) the name of the manufacturer of the chassis;
- (b) model;
- (c) engine number and number of cylinders;
- (d) year manufactured;

LAWS OF TRINIDAD AND TOBAGO

120

Chap. 48:50

Motor Vehicles and Road Traffic

[Subsidiary]

Motor Vehicles and Road Traffic Regulations

- (e) factory number of chassis, body number or VIN number;
- (f) maximum gross weight in kilogrammes;
- (g) type of body.

so, however, that a registered owner of a private motor vehicle or motorcycle where such motor vehicle or motorcycle is five years old or more, shall produce it for inspection by an examiner biennially, at such premises designated for that purpose as the Licensing Authority may direct.

(2) Where an owner is unable to furnish the information required, the Transport Officer may describe such vehicle from his own observation.

(3) The examiner shall examine the motor vehicle or motorcycle, and if satisfied that it complies with the Act and these Regulations and on payment of the prescribed fee, shall issue a certificate containing such particulars as specified by the Licensing Authority

(4) The Transport Officer shall keep a register in the form in the First Schedule of all certificates granted by him.

(5) Every Transport Officer may call up for examination at any time any motor vehicle or trailer which he has reason to believe is not in a fit and proper state of repair or does not conform to the provisions of the Act and of these Regulations as regards construction, equipment and maintenance.

(6) The Licensing Authority may at any time by notice in writing require the registered owner of a motor vehicle or trailer to produce the same for its inspection, and such owner shall produce the same accordingly.

(7) The Licensing Authority may issue renewals of conductor's permits between 15th and 31st December, to become effective on the following 1st January.

(8) Where a Transport Officer has examined a motor vehicle or trailer under subregulation (5) and determines that it is not in a fit and proper state of repair he shall immediately report that fact to the Licensing Authority.

(9) Where a motor vehicle or trailer referred to in subregulation (8) was issued a certificate in accordance with subregulation (3) the person who issued the certificate is guilty of an offence where it is determined that the motor vehicle or trailer was defective at the time of inspection.

(10) A person who commits an offence under subregulation (9) is liable on summary conviction to a fine of fifty thousand dollars or imprisonment for one year.

(11) A registered owner of a private motor vehicle or motorcycle, public service motor vehicle, rental car, goods vehicle, omnibus or trailer who fails to produce the vehicle for inspection or drives the vehicle without obtaining an inspection sticker and certificate in accordance with these Regulations commits an offence and is liable, on summary conviction, to a fine of five thousand dollars.

(12) A person who uses an inspection sticker or an inspection certificate, without authorisation, commits an offence and is liable on summary conviction to imprisonment for one year and a fine of fifteen thousand dollars.

***PART VA**

AUTHORISED EXAMINERS AND PREMISES

27A. (1) Applications for authorisations of premises to be used for inspections of motor vehicles may be made by—

- (a) an individual proposing to carry out examinations otherwise than on behalf of any other person;
- (b) persons in partnership; or
- (c) a company,

Applications for authorisations. [197/1999 34/2003].

hereinafter referred to as “proprietor”.

(1A) A person who desires to become an examiner shall apply to the Transport Commissioner.

(2) Every application shall be made on a form approved by the Licensing Authority and signed, where the application is made under paragraph (1)(a), by the individual

*See Note on LN 197/1999 at page 3.

making the application and, where the application is made under paragraph (1)(b) or (c) by a person duly authorised by the firm or company.

(3) In a case where the applicant proposes to carry out examinations at more than one place the Licensing Authority may require as many applications to be made as there are such places.

Authorisations.
[197/1999
34/2003].

27B. (1) When an application has been made in accordance with regulation 27A the Licensing Authority may, after making such investigations and carrying out such inspections as it may think fit, authorise the individual, persons in partnership or company by whom the application is made to have their premises used for the purpose of carrying out examinations of any class or classes of motor vehicles for a period of one year.

(2) The Licensing Authority may, at any time, if it so thinks fit, authorise in writing any person to carry out examinations notwithstanding that the requirements of regulation 27A have not been complied with.

(3) An application for the renewal of authorisation to carry out inspections may be made no more than one month before the expiration of the authorisation.

(4) A person who fails to apply for the renewal of authorisation prior to the expiration of the period of authorisation, shall submit forthwith to the Licensing Authority all—

- (a) unused inspection stickers;
- (b) unused inspection certificates;
- (c) check lists; and
- (d) monthly returns.

(5) A person who fails to comply with subregulation (4) commits an offence and is liable, on summary conviction, to a fine of five thousand dollars.

(6) A proprietor or examiner who conducts inspections of motor vehicles for the purpose of these Regulations without the required authorisation commits an offence and is liable on summary conviction to imprisonment for one year and a fine of twenty thousand dollars.

(7) A person guilty of an offence under subregulation (6) shall, in addition to the penalty stipulated for the offence therein, be required to reimburse any fee paid by a motorist whose motor vehicle had been inspected by him during the period he was not authorised to inspect motor vehicles.

(8) A motorist whose vehicle was inspected by an unauthorised examiner shall, within thirty days of being informed by the Licensing Authority that his inspection was invalid, have his vehicle inspected in accordance with these Regulations.

27C. (1) Subject to these Regulations, every proprietor shall comply with such conditions set out in the document entitled “Responsibilities of a vehicle testing station Proprietor or Examiner” as indicated in the Sixth Schedule and also with the following conditions:

Conditions to be complied with by proprietors. [197/1999 34/2003]. Sixth Schedule.

- (a) the proprietor shall arrange in accordance with these Regulations examinations of motor vehicles of any such class as is specified in the authorisation of the proprietor and shall in all other respects comply with such of the provisions of these Regulations as apply to the proprietor;
- (b) the proprietor shall arrange for examinations to be carried out or to be personally supervised, and for test certificates to be signed, by persons who—
 - (i) are competent to act for such a purpose; and
 - (ii) if they are not the proprietor or, where the proprietor consists of persons in partnership with one of those persons, carry out the examination in a manner which is under the direct control of the proprietor,

save that no person shall be first authorised to carry out or supervise an examination or sign a test certificate unless he has successfully completed a course of instruction approved for the purpose by the Licensing Authority as set out in paragraph 4 of the Sixth Schedule;

Sixth Schedule.

LAWS OF TRINIDAD AND TOBAGO

124

Chap. 48:50

Motor Vehicles and Road Traffic

[Subsidiary]

Motor Vehicles and Road Traffic Regulations

- (c) the proprietor shall supply the Licensing Authority with the names of all persons who are from time to time authorised in pursuance of arrangements made in accordance with subparagraph (b) to carry out or personally supervise examinations at that station and in either case to sign test certificates; and such names shall be given within seven days after the date of any such authorisation;
- (d) the proprietor shall put up and keep exhibited inside the vehicle testing station of that proprietor in some conspicuous place so as to be legible to persons submitting vehicles for examination at that station—
 - (i) the authorisation in which that vehicle testing station is specified; and
 - (ii) a list of the names of the persons for the time being authorised to carry out or personally supervise examinations at that station and in either case to sign test certificates;
- (e) the proprietor shall put up and keep exhibited outside the vehicle testing station of that proprietor in a conspicuous place a sign of the size, colour and type shown in Part I of the Seventh Schedule and complying with the conditions specified in Part II of the Sixth Schedule;
- (f) the proprietor shall, after not less than three clear days' notice given to that proprietor by the Licensing Authority, make the vehicle testing station of that proprietor and the apparatus at that station with which examinations are carried out available for the purpose of an examination to be carried out by the Licensing Authority as a result of an appeal

Seventh
Schedule.

Sixth Schedule.

which has been made against the refusal of a test certificate, whether by that or any other authorised proprietor or by an inspector appointed by the Licensing Authority;

(g) the proprietor shall give notice to the Licensing Authority at the sub-office in which is situated the vehicle testing station of the proprietor—

- (i) in a case where the proprietor is the sole individual named in an authorisation, of his entering into any partnership with a view to carrying on a business which will comprise the carrying out of examinations at that station; and
- (ii) in a case where the proprietor consists of persons in partnership, of any change in the constitution of the firm,

and such notice shall be given not later than seven days after the occurrence of the entry into partnership or the change in the constitution, as the case may be.

(2) The Licensing Authority may give notice to a proprietor that in the opinion of the Licensing Authority a person should not carry out or supervise examinations, or sign test certificates, and on receipt of that notice the proprietor shall arrange that that person shall no longer carry out or supervise examinations or sign test certificates, as the case may require.

27D. (1) An authorisation of an individual as a proprietor terminates if he—

- (a) dies;
- (b) commits a criminal offence;
- (c) is adjudged bankrupt;
- (d) becomes mentally incapacitated; or
- (e) is found to be in breach of his duties under the Act.

Termination of
authorisation.
[197/1999].

(2) An authorisation as a proprietor of persons in partnership terminates if the firm is dissolved.

(3) An authorisation of a company as a proprietor terminates if in relation to the company—

- (a) a winding-up order is made;
- (b) a resolution for voluntary winding up is passed;
- (c) a receiver or manager of the body's undertaking is appointed; or
- (d) the taking of possession, by or on behalf of the holders of any debenture secured by a floating charge, or of any property of the body comprised in or subject to the charge occurs.

(4) Notwithstanding these Regulations, the person to whom is assigned responsibility for undertaking the activities specified in subregulation (3)(a) to (d) may apply for an authorisation in accordance with the provisions of regulation 27A to the Licensing Authority who may act in accordance with regulation 27B.

(5) A proprietor may at any time give notice to the Licensing Authority stating that after such date as may be specified in the notice that proprietor does not propose to continue to act as a proprietor under any of the authorisations of that proprietor or under such authorisation as may be specified in the notice, and any authorisation to which the said notice relates shall cease to have effect on the date so specified in relation to it.

(6) The Licensing Authority may terminate the authorisation of an individual as a proprietor or examiner on the following grounds:

- (a) the improper or fraudulent issue of a test certificate;
- (b) the deliberate failure to report the loss or theft of any certification relating to the inspection process to the Licensing Authority or the police;

- (c) the conviction of the proprietor or examiner under his control for any criminal offence that in the opinion of the Licensing Authority is likely to damage the integrity of the inspection programme;
- (d) the continued failure to comply with the provisions of these Regulations and any additional directives of the Licensing Authority.

(7) In pursuance of subsection (6), the Licensing Authority may at any time give to a proprietor a notice which states—

- (a) that from the date specified in the notice such one or other of the authorisations of the proprietor as specified in the notice shall, unless the notice is cancelled before that date, cease;
- (b) in a case where the date on which an authorisation ceases is less than twenty-one days from the date of the notice, that the Licensing Authority considers it necessary that the notice will have early effect;
- (c) that within twenty-one days from the date of the notice, the proprietor or any person acting on his behalf may appeal the decision of the Authority to the Trinidad Transport Board who shall determine whether the notice of termination shall be upheld or cancelled.

(8) An authorisation in respect of which a notice is given in accordance with subsection (6) shall, except as is provided in paragraph (6)(a), cease on the date specified in the notice as the date upon which the authorisation shall cease.

(9) The termination of an authorisation shall be effective from such time specified in the notice given under subsection (6) or for such period as is determined by the Trinidad Transport Board upon an appeal under subsection (6).

LAWS OF TRINIDAD AND TOBAGO

128

Chap. 48:50

Motor Vehicles and Road Traffic

[Subsidiary]

Motor Vehicles and Road Traffic Regulations

Forms and documents to be returned to Transport Commissioner. [197/1999 34/2003].

27E. (1) If an authorisation of a proprietor ceases to have effect, the former proprietor or, if appropriate, his authorised representative, shall send to the Licensing Authority such of the following documents as are then in the possession of the proprietor:

- (a) all unused forms of test certificates, inspection check lists, inspection stickers, monthly return forms and notices of refusal to issue a test certificate;
- (b) all copies of test certificates and notices of the refusal of test certificates;
- (c) all other records kept in accordance with regulation 27P; and
- (d) in the case of the authorisation of a proprietor ceasing to have effect, the document of authorisation,

save that where an authorisation of a proprietor ceases to have effect but some other authorisation of that proprietor continues in force the Licensing Authority may consent to the retention by that proprietor of all or any of the documents mentioned in paragraphs (a) to (d).

(2) On receipt by the Licensing Authority of any unused forms of test certificates sent to it in accordance with subregulation (1) it shall repay to the authorised proprietor or the authorised representatives of that proprietor, as the case may be, such amount as may have been paid to the Licensing Authority for the supply of the said forms.

(3) The Licensing Authority may in respect of unissued forms of test certificates which are returned to it as having been cancelled because they have been spoilt or defaced make an appropriate refund to the proprietor by whom the forms are so returned.

Application for examination. [197/1999 34/2003].

27F. (1) An application for an examination of a vehicle under these Regulations shall be made to the Transport Commissioner.

LAWS OF TRINIDAD AND TOBAGO

(2) An application for an examination (including a re-examination) of a vehicle in a class other than Class VI under these Regulations shall be made as indicated in the Table below —

(1)	(2)	(3)
Item No.	Person or body to whom application must be made	Manner in which Appointment must be made
1.	A proprietor	By arrangement following application made in writing or, during the normal working week, by telephone to, or in person at (whether by submitting the vehicle or not), the vehicle testing station where the applicant desires the vehicle to be examined.
2.	The Transport Commissioner	By arrangement following prior Application.

(3) Subject to the following provisions of these Regulations, proprietors shall ensure that:

- (a) where in accordance with the provisions of paragraph (2) an appointment is requested for the carrying out of an examination by the proprietor, an appointment is forthwith offered for the carrying out of the examination at the earliest time at which it is reasonably practicable for the examination to be carried out during the normal working week;
- (b) where in accordance with the provisions of paragraph (2) a vehicle is submitted for examination by the proprietor or, as the case may

be, the Licensing Authority without any appointment for the carrying out of the examination having been previously made, the applicant is informed either that the examination can be carried out forthwith or, if not, of the earliest time at which it is reasonably practicable for the examination to be carried out during the normal working week;

- (c) except in so far as prevented by circumstances beyond the control of the proprietor or the Licensing Authority examinations are carried out in accordance with the appointments made or the information given in pursuance of the preceding provisions of this paragraph or at such other times as may be arranged between the applicant and the proprietor.

(4) On an appointment being made or a time being arranged for the carrying out of an examination in accordance with paragraph (3) the proprietor or the Licensing Authority as the case may be, shall record the hour and the date thereof and the name of the person by whom the application for the examination is made: Save that no such record needs to be made in a case where a vehicle is submitted for examination at a vehicle testing station of a proprietor, without any appointment for the carrying out of the examination having been previously made, and the examination is carried out forthwith.

(5) Any examiner and any inspector appointed by the Licensing Authority may carry out an examination of a motor vehicle in accordance with the provisions of these Regulations notwithstanding that the foregoing provisions of this regulation have not been complied with.

(6) Nothing in this regulation shall be taken as entitling an examiner to carry out an examination of a vehicle not being of a type included in the authorisation of the proprietor.

27G. A proprietor appointed shall not be under obligation to carry out an examination of a motor vehicle where—

- (a) on the submission of a vehicle for an examination the applicant does not, after being requested to do so, produce his driver's permit and certified copy of ownership of the vehicle and the serial number and the engine number given to the vehicle by its manufacturer and, if the manufacturer has also given the vehicle an identification number, that number also;
- (b) the vehicle or any part thereof or any of its equipment is so dirty as to make it unreasonably difficult for the examination to be carried out in accordance with the provisions of these Regulations;
- (c) the proprietor or Transport Officer is not able with the facilities and apparatus available to him at the place at which the examination would otherwise be carried out to complete the examination without the vehicle being driven and the vehicle is not when submitted for examination, either for want of fuel or oil or for any other reason, fit to be driven to such extent as may be necessary for the purposes of the carrying out of the examination;
- (d) before the carrying out of an examination of a motor vehicle, any things which are on the vehicle, and are not part of its equipment or accessories, are required by the proprietor or Transport Officer to be removed from the vehicle or to be secured in such manner as he may think necessary and the things are not removed or secured accordingly; and
- (e) in a case where the fee for the examination is payable in advance of the examination the examiner, or Transport Officer or the Licensing Authority is not satisfied that the fee payable for the examination has been paid as required under these Regulations.

Requirements as to vehicles submitted for examination. [197/1999 34/2003].

LAWS OF TRINIDAD AND TOBAGO

132

Chap. 48:50

Motor Vehicles and Road Traffic

[Subsidiary]

Motor Vehicles and Road Traffic Regulations

Conditions as to
responsibility
for damage to
vehicles and
third party.
[197/1999].

27H. (1) Where a motor vehicle has been submitted for an examination to be carried out by a proprietor or the Licensing Authority, the proprietor or the Licensing Authority as the case may be, shall have the same responsibility for—

- (a) loss of or damage to the vehicle or its equipment or accessories occurring in connection with the carrying out of the examination during any period while the vehicle is, in connection with the carrying out of the examination, in the custody of the proprietor or the Licensing Authority; and
- (b) loss of or damage to any other property or personal injury, whether fatal or not, being loss, damage or injury arising out of the use of the vehicle in connection with the carrying out of the examination,

as would rest on a person who, having the same facilities for carrying out the examination as are available to the person who is to carry out the examination, had undertaken for payment to accept the custody of the vehicle and to carry out the same examination under a contract making no express provision with respect to the incidence of liability as between the parties thereto for any such loss, damage or injury.

(2) No person submitting a vehicle for an examination or having an interest in such a vehicle shall be requested or required by a proprietor or the Licensing Authority either directly or indirectly to accept any responsibility for, or to give any release or indemnity in respect of, any loss, damage or injury for which the proprietor or the Licensing Authority as the case may be is responsible under subregulation (1).

(3) Nothing in subregulation (1) or (2) shall preclude any person from being requested or required to accept any responsibility for, or to give a release or indemnity in respect of—

- (a) loss of or damage to a vehicle or its equipment or accessories occurring during any period while the vehicle is in the custody of a proprietor or the

Licensing Authority after the time when the vehicle is required to be removed from such custody in pursuance of the provisions of regulation 17(1); or

- (b) loss, damage or injury arising out of the carrying out by a proprietor, at the request of the person submitting the vehicle for an examination or of a person having an interest in the vehicle, of repairs to the vehicle or of repairs or replacements of its equipment or accessories.
- (4) In this regulation—
- (a) references to an examination, in relation to a vehicle which, after the carrying out of an examination, remains in the custody of a proprietor, in order that a further examination of that vehicle may be carried out, include references to that further examination; and
 - (b) references to a period while a vehicle is in the custody of the Licensing Authority include references to any period while a vehicle is, in connection with the carrying out of an examination of the vehicle by an inspector appointed by the Licensing Authority in the control or care of such an inspector.

27I. (1) Subject to the provisions of these Regulations, an examiner or the Licensing Authority shall, after an examination of a motor vehicle is completed and, subject to subregulation (2), on the same date as that on which the examination is completed—

Results of
examinations.
[197/1999
34/2003].

- (a) where it is found on the examination that the prescribed statutory requirements are complied with in relation to the vehicle, issue a test certificate;
- (b) where it is not so found on the examination, issue a notice of the refusal of a test certificate; and
- (c) issue an inspection checklist on a form approved by the Licensing Authority.

(2) Where it is not practicable for a test certificate and inspection checklist to be issued on the same date as that on which the examination of the vehicle is completed the certificate and list may be issued within one day following that date, if between the time of the completion of the examination and the time of issue of the test certificate the vehicle has not been moved from the vehicle testing station at which the examination was carried out and the condition of the vehicle has not altered so as to result in the prescribed statutory requirements being no longer complied with in relation thereto, and where it is not practicable for a notice of the refusal of a test certificate and inspection checklist to be issued on the same date as that on which the examination of the vehicle is completed, the said notice and list may be issued within one day following that date.

(3) Subject to the provisions of these Regulations—

(a) every test certificate shall be on a form supplied by the Licensing Authority and shall contain—

- (i) particulars of the registration mark if any, exhibited on the vehicle or, if no such mark is exhibited, the chassis or serial number marked on the vehicle;
- (ii) the make of the vehicle, its approximate year of manufacture, and the mileage recorded by any odometer with which it is fitted;
- (iii) if the vehicle is a goods vehicle, its unladen weight specified in kilograms, or if it is not a goods vehicle, its horse-power or cylinder capacity;
- (iv) a statement that the vehicle has been found on examination to comply with the prescribed statutory requirements;
- (v) the number of the vehicle testing station where the examination occurred;
- (vi) the date of the issue of the test certificate and the date on which it will expire;

- (vii) if the date of the expiry of the certificate is more than twelve months after the date of its issue, the serial number of the certificate last issued in respect of the vehicle;
- (b) every notice of the refusal of a test certificate shall be on a form supplied by the Licensing Authority and shall contain—
 - (i) the information mentioned in subparagraph (a)(i), (ii) and (iii);
 - (ii) a statement that the application for a test certificate is refused, and the grounds of such refusal; and
 - (iii) the date on which the notification is issued and the number allotted by the Licensing Authority to the vehicle testing station at which it is issued.

(4) Every test certificate, notice of the refusal of a test certificate and inspection checklist issued in accordance with this regulation and regulation 27J shall, after the examination has been carried out, be signed—

- (a) where the examination is carried out at the premises of a proprietor, by the person who carried out the examination;
- (b) (*Deleted by LN 34/2003*),

and any signature on a test certificate or notice of refusal of a test certificate by a person in accordance with subparagraph (a) shall be accompanied by an embossment by a stamp of the proprietor or the Licensing Authority on whose behalf the certificate or notice is signed.

27J. (1) Where in the course of an examination of a vehicle by an examiner or the Transport Officer it is found that there are such defects in the construction or condition of the vehicle or its equipment or accessories that to carry out a braking test of the vehicle in the manner in which braking tests of such vehicles are carried out at the vehicle testing station at which the examination

Refusal of a test certificate where braking test cannot be carried out. [197/1999 34/2003].

is being carried out would be likely to cause danger to any person or damage to the vehicle or any other property, the proprietor or the Transport Officer shall not carry out the braking test but shall complete the rest of the examination in accordance with the provisions of these Regulations.

(2) Where in any such case as is mentioned in paragraph (1) a proprietor or the Licensing Authority does not carry out a braking test of a vehicle, he shall provide the applicant for the test with a notice on a form supplied by the Licensing Authority and stating—

- (a) that he could not safely carry out the braking test, and the reason therefor; and
- (b) the particulars mentioned in regulation 27I(3)(b)(ii) and (iii).

(3) In this regulation “braking test” means that part of the examination of that vehicle which is required or authorised to be carried out to ascertain whether the braking requirements are complied with.

Removal of
vehicles
submitted for
examination.
[197/1999].

27K. (1) Where a vehicle has been submitted for an examination at a vehicle testing station of a proprietor or the Licensing Authority, the person by whom the vehicle has been so submitted shall, save as may otherwise be permitted by the proprietor, or the Licensing Authority, as the case may be, cause it to be removed from the custody of the proprietor or the Licensing Authority, as the case may be—

- (a) where an appointment or arrangement has been made for the carrying out of the examination on a particular day and the examination has been completed on or before that day, before the end of the second day after that day; or
- (b) in any other case, before the end of the second day after the day on which the person submitting the vehicle for examination is given notice whether in writing or not—
 - (i) that the examination has been carried out; or

- (ii) in a case where the examination is not carried out by reason of any of the provisions of regulation 27G that he is to remove the vehicle from such custody.

(2) In this regulation references to an examination, in relation to a vehicle which, after the carrying out of an examination, remains in the custody of a proprietor, or the Licensing Authority in order that a further examination of that vehicle may be carried out, include references to that further examination.

27L. (1) A person to whom a notice of the refusal of a test certificate has been issued may appeal to the Licensing Authority and, save as may be otherwise permitted by the Licensing Authority any such appeal shall—

Appeal on refusal of a test certificate. [197/1999 34/2003].

- (a) be on a form approved by the Licensing Authority and contain the particulars required by that form; and
- (b) be sent to the office of the Licensing Authority within fourteen days from the date of the said notice.

(2) Within twenty-one days after the date on which the Licensing Authority receives a notice in accordance with subregulation (1) he shall send to the applicant, at his address given on the said notice, a notice stating—

- (a) the place at which the examination for the purposes of the appeal will occur; and
- (b) the time at which that examination will start.

(3) Save as may be otherwise permitted by the Licensing Authority, the examination mentioned in subregulation (2), shall not occur unless the applicant, or a person acting on his behalf—

- (a) submits the vehicle in respect of which the appeal is made to the place specified in the notice given by the Licensing Authority mentioned in subregulation (2), not later than the time specified in that notice as that at which the examination will start;

- (b) produces to the person appointed by the Licensing Authority to carry out the examination—
 - (i) the notice of the refusal of a test certificate issued as a result of the examination in connection with which the appeal is made; and
 - (ii) the registration document relating to the vehicle or other sufficient evidence of the date of its registration or date of manufacture; and
- (c) gives to that person such information as he may reasonably require in connection with the carrying out of the examination relating to any alteration made or repairs carried out or any accident or other event occurring, since the date of the said notice, which may have affected the vehicle or its equipment or accessories,

and the said officer shall not be required to carry out the examination unless such notice, registration document or other evidence is produced and such other information is given.

(4) When a person completes an examination under the provisions of this regulation he shall issue to the appellant—

- (a) either—
 - (i) a test certificate; or
 - (ii) a notice of the refusal of a test certificate stating the grounds thereof; and
- (b) an inspection checklist.

(5) Test certificates, notices of the refusal of a test certificate, and inspection checklists issued under this regulation—

- (a) shall, subject to such modifications as may be appropriate, be in the same form and contain the same particulars as are appropriate in the case of a test certificate, notice of the refusal of a test certificate and an inspection checklist issued under the provisions of these Regulations; and

(b) shall be signed on behalf of the Licensing Authority by the officer carrying out the examination for the purposes of the appeal.

(6) The provisions of this regulation do not apply where a notice of refusal of a test certificate has been issued following an examination for the purpose of an appeal.

27M. (1) Where arrangements are made for the carrying out at a vehicle testing station of a proprietor of an examination for the purposes of an appeal under regulation 27L an amount equal to one-half of the amount payable on that appeal shall be payable by the Licensing Authority to that proprietor in respect of the use of the station and apparatus thereat to be made available under the said arrangements.

Payment to proprietors at whose premises examinations on appeals are carried out. [197/1999 34/2003].

Except that the amount shall not be payable—

- (a) if the Licensing Authority gives the proprietor not less than one day’s notice, whether in writing or otherwise, that the examination is not to take place in accordance with the said arrangements; or
- (b) if the proprietor does not make the testing station and the apparatus available to the Licensing Authority to his reasonable requirements.

(2) Where the Licensing Authority has issued a certificate after a successful appeal, the proprietor shall refund to the Authority the costs of such appeal.

27N. (1) The fee for an examination of a vehicle pursuant to an application made under regulation 27F is—

Fees for examination. [197/1999 34/2003].

- (a) in the case of a motorcycle not having a side car attached to it, \$112.00; or
- (b) save as provided in paragraph (4) in the case of a privately owned light motor vehicle, \$165.00.

(2) Subject to the following provisions of this regulation, every fee prescribed by paragraph (1) shall be paid:

- (a) if the application is one to which item 1 in the Table to regulation 27F(1) applies, or is one, other

than an application for re-examination, to which item 2 in that Table applies, by a remittance accompanying the application;

- (b) if the application is one to which regulation 27F(2) applies or, in the case of an application for a re-examination, is one to which item 2 in the Table to regulation 27F(1) applies—
- (i) before the examination is carried out if the Licensing Authority or the proprietor by whom the examination is to be carried out so requires; and
 - (ii) after the examination is carried out in all other cases.

(3) Where, on an examination of a vehicle it is found that some or all of the prescribed statutory requirements are not complied with or where, in the circumstances mentioned in regulation 27J, a full examination of the braking system or systems of the vehicle is not carried out, then—

- (a) if the vehicle is left at the vehicle testing station at which the examination took place so that the defects which have been revealed can be repaired, no fee shall be payable in respect of any further examination carried out there on the completion of those repairs;
- (b) if the vehicle is removed from the vehicle testing station in consequence of a notice of refusal of a test certificate but within six weeks of the date of issue of the notice, it is brought to and left at that vehicle testing station for a second examination there shall be no fee payable in respect of that further examination; however—
- (i) if a vehicle is brought back to the same vehicle testing station for a third examination, a fee of \$100 shall be payable; and
 - (ii) if a vehicle is brought to another vehicle testing station the amount payable in subregulation (1) shall be payable.

(4) The fees prescribed by subregulations (1) and (3)(b), shall be payable notwithstanding that the vehicle is not submitted for examination in accordance with any such appointment or arrangement as is mentioned in regulation 27F:

Save that if the applicant for the examination has not less than one day before the time so appointed or arranged given the examining authority notice, whether in writing or otherwise, that the applicant does not propose to submit the vehicle for examination at the time so appointed or arranged, the application shall be treated for the purposes of this regulation as one in respect of which no fee is payable and any amount previously paid in respect of such a fee shall be repayable by the examining authority to the applicant unless another time is arranged for the carrying out of the examination.

(5) No fee shall be payable on an application for an examination of any vehicle in any case where in pursuance of any of the provisions of regulation 27G an authorised proprietor or the Licensing Authority does not carry out the examination, and any amount previously paid in any such case in respect of such a fee shall be repaid by the examining authority to the applicant.

(6) *(Deleted by LN 34/2003).*

27O. (1) The fees payable on an appeal made in accordance with regulation 27L are the same amount as the fees payable under regulation 27N. Fees on appeals. [197/1999 34/2003].

(2) Save as provided in paragraph (4), every fee prescribed by paragraph (1) as the fee payable on an appeal shall be paid at the same time as the appeal is made, and if that fee is not so paid the Licensing Authority shall not be obliged to deal with the appeal.

(3) After the completion of the examination for the purposes of the appeal the Licensing Authority may repay to the appellant, as he think fit, either the whole or a part of the fee paid on the appeal where it appears to him that there are substantial grounds for contesting the whole or part of the decision appealed against.

(4) A fee payable on an appeal in accordance with this regulation shall be payable notwithstanding that the vehicle is not submitted for examination in accordance with the provisions of regulation 27L:

Except that if the appellant has before the time fixed under regulation 27L for the carrying out of the examination given the Licensing Authority not less than two days' notice, whether in writing or otherwise, at the office of the traffic area at which his appeal was lodged or if he has been given such notice as is specified in regulation 27L(2), at the address specified in that notice as the address to which any communication relating to the appeal is to be sent, that the appellant does not propose to submit the vehicle for examination at that time, the appeal shall be treated for the purposes of this regulation as one in respect of which no fee is payable and any amount previously paid in respect of such a fee, shall be repaid by the Licensing Authority to the appellant unless another time is arranged for the carrying out of the examination.

Records to be kept and returns to be furnished by proprietors. [197/1999 34/2003].

27P. (1) Proprietors shall make, in duplicate, at each of their respective vehicle testing stations a record relating to all examinations carried out at that station, and that record shall be on a form supplied by the Licensing Authority and contain the particulars required by that form.

(2) On one of the first seven days of each month each authorised proprietor shall send to the Licensing Authority—

- (a) one copy of the record containing all the entries made therein relating to any examination as a result of which a test certificate or a notice of the refusal of a test certificate has been issued during the last preceding month; or
- (b) if no such certificate or notification has been issued, a notice to that effect.

(3) Subject to the following provisions of these Regulations, the other copy of the record shall be kept by the proprietor at the station at which the examinations to which it relates

are carried out for a period sufficient to ensure that upon the inspection at any time of that record the entries relating to any examination carried out within the last preceding eighteen months will be available for inspection.

28. No person shall cause or permit a motor vehicle to be used on any public road, or shall drive or have charge of a motor vehicle when so used unless the conditions set out below are satisfied, namely—

- (a) the motor vehicle, if it exceeds in weight unladen three hundred and sixty-five kilograms, shall be capable of being so worked that it may travel either forward or backwards; Reversing.
- (b) no motor vehicle or trailer shall exceed two and a half metres in overall width; Width.
- (c)
 - (i) no motor vehicle constructed for the carriage of passengers only shall exceed ten metres in overall length, except trolley buses operated by the Port-of-Spain Corporation which may be of an overall length not exceeding ten metres. No other motor vehicle shall exceed nine metres in overall length; Length.
 - (ii) no trailer other than a semi-trailer shall exceed seven metres in overall length;
 - (iii) no motor vehicle and semi-trailer attached shall exceed eleven metres in overall length;
 - (iv) no motor vehicle and trailer attached shall exceed fourteen metres in overall length: Provided that the overall length of a motor vehicle and pole trailer carrying pipes may extend to fifteen and a half metres and of an agricultural tractor drawing two trailers to seventeen metres;
- (d) except with the permission of the Licensing Authority, no motor vehicle or trailer shall have Overhang.

Conditions of use of motor vehicles on public road. [197/1999].

Reversing.

Width.

Length.

Overhang.

LAWS OF TRINIDAD AND TOBAGO

144

Chap. 48:50

Motor Vehicles and Road Traffic

[Subsidiary]

Motor Vehicles and Road Traffic Regulations

a lateral overhang of more than one hundred and fifty-five millimetres or a longitudinal overhang which exceeds seven twenty-fourths ($\frac{7}{24}$ ths) of the overall length of the vehicle, and when a trailer is connected to a motor vehicle by a bar or pipe, such bar or pipe shall not be allowed to project more than one metre beyond the rear of the trailer;

Distribution of weight.

- (e) (i) the total weight transmitted to the road surface by the wheels of any one axle of a motor vehicle or trailer shall not exceed ten tonnes;
- (ii) the combined gross weights of a motor vehicle and trailers shall not exceed the weight arrived at by the formula “eight thousand one hundred and sixty-five kilogrammes + (L x 800)” where L equals the length in millimetres measured from the centre of the front wheels to the centre of the rearmost wheels of the vehicle or combination of vehicles;
- (iii) for the purposes of this paragraph two or more axles in line transversely and two or more axles the distance between the centre lines of which is less than one and three-tenths metres shall be deemed to be a single axle;

Brakes.

- (f) (i) every motor vehicle shall be equipped with an efficient braking system or efficient braking systems in either case having two means of operation so designed and constructed that one means of operation shall apply brakes to not less than all the wheels on each of two axles (or in the case of a motorcycle, one axle) of the motor vehicle and that

notwithstanding the failure of any part (other than a fixed member or a brake shoe anchor pin) through or by means of which the force necessary to apply the brakes is transmitted, there shall still be available for application by the driver to not less than half the number of the wheels of the vehicle (or in the case of a motorcycle or a motor vehicle having less than four wheels to not less than one wheel) brakes sufficient under the most adverse conditions to bring the vehicle to rest within a reasonable distance:

Provided that a motor vehicle manufactured prior to 1st January 1935, may be fitted with brakes capable of being applied to all the wheels of one axle but the braking system or systems of such motor vehicle shall have two independent means of operation as prescribed;

- (ii) all the brakes of a motor vehicle which are operated by one of the means of operation shall be capable of being applied by direct mechanical action without the intervention of any hydraulic, electric, pneumatic or any other device;
- (iii) one at least of the means of operation shall be capable of causing the brakes to be applied directly and not through the transmission gear to not less than half the number of the wheels of the vehicle;
- (iv) in the case of a steam driven vehicle which is not used as a public service vehicle for the conveyance of passengers for gain or hire, the engine of the vehicle shall be deemed to be an efficient braking system if the engine is capable of being reversed

LAWS OF TRINIDAD AND TOBAGO

146

Chap. 48:50

Motor Vehicles and Road Traffic

[Subsidiary]

Motor Vehicles and Road Traffic Regulations

and is incapable of being disconnected from any of the driving wheels except by the sustained effort of the driver;

- (v) every part of every braking system and of the means of operation thereof fitted to a motor vehicle or trailer, shall at all times, while the motor vehicle or trailer is used on a road, be maintained in good and efficient working order and shall be properly adjusted;

Trailers.

- (g) every trailer other than an agricultural trailer shall have an efficient braking system, approved by the Licensing Authority, the brakes of which are capable, when a trailer is being drawn, of being applied to at least two wheels. This paragraph shall not apply in the case of a pole trailer unladen or carrying an indivisible load;

Weight shown in certain cases.

- (h) every goods vehicle, motor omnibus or trailer shall have its tare and M.G.W. painted in white figures and letters not less than sixty-five millimetres in height upon a black ground on a conspicuous place on the right or off side of such vehicle to be specified by the Transport Officer. Such weights shall be expressed in kilogrammes;

Condition of vehicle.

- (i) the motor vehicle or trailer and all the fittings thereof shall be in such a condition as not to cause, or to be likely to cause, danger to any person on the motor vehicle or trailer or on any public road;

Silencers.

- (j) all motor vehicles shall be fitted with silencers to the satisfaction of the Licensing Authority.

Cut-outs.

The use of cut-outs is forbidden throughout Trinidad and Tobago;

Unauthorised lights.

- (k) there shall not be affixed to the front of a motor vehicle any lighted lamp other than the headlights and side lights except with the approval in writing of the Licensing Authority, nor to the rear of a

motor vehicle or trailer any lighted lamp other than the red light prescribed by these Regulations except as permitted by paragraph (m)(iii) of this regulation;

- (l) there shall not be painted or otherwise affixed to the front or rear of a motor vehicle any combination of letters or figures resembling, or likely to obscure, or likely to be confused with, the letters and figures on the identification plate prescribed by these Regulations, and no letters or figures other than those on the identification plate shall be painted or affixed within five hundred millimetres of the identification plate;
- (m) (i) every motor vehicle shall be equipped with a minimum of two lamps at the front of the vehicle, one on each side to the satisfaction of the Licensing Authority. When a motor vehicle is in motion on a road at night, the lamps at the front of the vehicle shall be lighted, and the rays from the lamps shall be of a type approved by the Licensing Authority and, if the vehicle is capable of proceeding at a speed greater than thirty kilometres per hour, of such intensity as to illuminate the road ahead for a distance of at least ninety-five metres or such greater distance as is sufficient to ensure the safety of the vehicle and the persons carried on the vehicle, and to indicate clearly the presence of the vehicle to approaching traffic. However, a motorcycle shall show one such lamp as aforesaid, but if a side-car is attached to the motorcycle, there shall be shown on that side of the side-car not adjacent to the motorcycle, an additional light of sufficient intensity to indicate the presence of the side-car from a reasonable distance to approaching traffic;
- (ii) save as is contained in regulation 92, when stationary on a road at night every motor

Unauthorised
letters and
figures.

Lights.

vehicle and every trailer not attached to a motor vehicle shall show two lights in front, one at each side, of sufficient intensity to indicate the presence of the motor vehicle or trailer from a reasonable distance to approaching traffic; but a motorcycle not attached to a side-car shall show one such light as aforesaid;

- (iii) save as provided elsewhere in these Regulations, every motor vehicle or trailer when on a road at night, whether in motion or stationary shall carry at least two lamps each showing a red light to the rear, of such intensity as to indicate clearly within a reasonable distance its presence on the road to traffic approaching from behind. There shall also be fitted lamps of such construction showing an uncoloured light of such intensity as to clearly illuminate the figures and numbers on the rear identification plate. Except as aforesaid, no other lamp shall be carried to the rear of the vehicle without the special written permission of the Licensing Authority. Where a trailer is attached to a tractor it will be sufficient if one such lamp as aforesaid is carried at the rear of the trailer only;
- (iv) no spot lights or other similar swivelling lamps shall be carried on any motor vehicle without the authority of the Licensing Authority, who may authorise such lights at his discretion and subject to such conditions as he may impose;
- (v) in addition to the foregoing provisions as to lamps to be carried, motor omnibuses shall also carry a lighted lamp on the inside top of the hood showing a white light visible within a reasonable distance in all directions;
- (vi) in the case of motor omnibuses and goods vehicles, when either of the lamps referred to

in subparagraph (i) hereof is placed in such a position that the distance of the centre of the lamp from the extreme outside point of the vehicle on its appropriate side exceeds three hundred millimetres, two additional lamps shall be fitted at the front of the said vehicle one on each side so that its centre shall not exceed the aforesaid distance of three hundred millimetres, and so as clearly to indicate the width of the vehicle to approaching traffic; the said lamps shall be focussed below the horizontal and shall exhibit a light of sufficient power only to indicate the width of the vehicle;

- (n) the exhaust pipe of a motor vehicle shall not be fixed in such a position that oil or any vaporisable or inflammable material is likely to be dropped upon it; the outlet thereof shall be placed far enough to the rear of the vehicle to prevent, as far as practicable, fumes from entering the vehicle.

29. Notwithstanding the provisions of regulation 28(m) (ii) and (iii), a motor vehicle when stationary at night within the boundaries of the City of Port-of-Spain, or the City of San Fernando, or the Boroughs of Arima, Chaguanas and Point Fortin need not show two lights in front and at least two lamps at the back if all the following conditions are complied with:

Stationary motor vehicle.
[197/1999].

- (a) if such vehicle is drawn up as close as possible to its left or near side of the road;
- (b) if there is affixed or painted on the rear of the vehicle a reflective material or substance that is easily visible to approaching traffic.

30. (1) Every motor vehicle or trailer manufactured after 1960 shall be fitted with directional indicators on either side of the front and rear of such vehicle, and every indicator shall be so designed and fitted that—

Direction indicators.
[197/1999].

- (a) it emits an amber light to the front and red or amber light to the rear;

LAWS OF TRINIDAD AND TOBAGO

150

Chap. 48:50

Motor Vehicles and Road Traffic

[Subsidiary]

Motor Vehicles and Road Traffic Regulations

- (b) it flashes at sixty to one hundred and twenty times a minute;
- (c) it shall not be more than one hundred and fifty-five millimetres measured horizontally from the outermost point of the side of the body immediately behind the driver's seat.

(2) Additional direction indicators may be fitted at the sides of the motor vehicle.

31. (1) (*Repealed by LN 197/1999*).

Left-hand driven vehicles.
[197/1999].

(2) All motor vehicles with left-hand steering shall have a notice, affixed in a conspicuous position on the rear of the vehicle, bearing the words, in letters of not less than fifty millimetres in height, "Left-Hand Drive".

PART VI

INSPECTION OF VEHICLES OTHER THAN MOTOR VEHICLES

Definition.
[177/1956].

32. In this Part—

"carriage" includes any vehicle drawn by a horse or other animal and used or intended to be used for the conveyance of passengers;

"cart" means any hand cart, dray, van, wagon, truck, car, sledge, barrow or any other vehicle or machine howsoever drawn or propelled, and used or intended to be used for the carrying or conveyance of any goods, wares or other burden whatsoever, but does not include a motor vehicle.

Bells, etc.
[177/1956
39/1957].

33. (1) Every cycle and every carriage on a road shall carry attached thereto a bell or other instrument approved by the Licensing Authority, capable of giving audible and sufficient warning of its approach or position.

(2) No person riding a cycle or driving a carriage on a road shall sound any bell or other instrument except for the purpose

of giving reasonable and necessary warning of the approach or position of such cycle or carriage.

34. (1) At night—

- (a) the person in charge of a carriage on a road shall carry attached thereto a lamp on each side of the carriage showing to the front a white light visible from a reasonable distance and a lamp on the right or off side of the carriage showing to the rear a red light visible from a reasonable distance;
- (b) the person in charge of a cart on a road shall carry attached thereto on the right or off side and above the level thereof and of the load (if any) carried therein, a lamp showing a white light visible from a reasonable distance in all directions, and on the off rear end an unobscured and efficient reflector of a type approved by the Licensing Authority;
- (c) the person in charge of a cycle on a road shall carry attached thereto a lamp showing to the front a white light visible from a reasonable distance, and either—
 - (i) a lighted lamp showing to the rear a red light, visible from a reasonable distance; or
 - (ii) an unobscured and efficient red reflector and in addition thereto an unobscured white surface which complies in all respects with the provisions of subregulation (2).

Lights on vehicles other than motor vehicles. [177/1956].

(2) Every white surface required to be exhibited under subregulation (1)(c) shall have an area of not less than five hundred and forty square millimetres, shall be kept clean and unobscured, and shall be so fixed that—

- (a) not less than half the area lies on the off-side of the centre line of the vehicle; and
- (b) not less than half the area is over two hundred and fifty-five millimetres above the ground.

LAWS OF TRINIDAD AND TOBAGO

152

Chap. 48:50 *Motor Vehicles and Road Traffic*

[Subsidiary]

Motor Vehicles and Road Traffic Regulations

For the purposes of this subregulation “white” includes the colour of polished aluminium or of chromium plating, or of a white reflective material.

Cycle brakes.
[177/1956].

35. (1) No person shall ride, or cause, or permit any cycle to be ridden on any road unless he complies with the provisions of this regulation.

(2) Every cycle having any wheel of which the outside diameter (including any tyre when fully inflated) exceeds four hundred and fifty-five millimetres shall —

- (a) if it is so constructed that one or more of the wheels is incapable of rotating independently of the pedals, be equipped with a braking system operating on the front wheel or both front wheels, if it has two front wheels;
- (b) if it is not so constructed as aforesaid, be equipped with two independent braking systems, one of which operates on the front wheel, or both the front wheels, if it has two front wheels, and the other of which operates on the rear wheel, or one of the rear wheels, if it has two rear wheels:

Provided that in the case of a tricycle not constructed or adapted for the carriage of goods it shall be a sufficient compliance with this subregulation if the tricycle is equipped with two independent braking systems operating on the front wheel if it has two rear wheels, or on the rear wheel if it has two front wheels.

(3) Every cycle other than is specified in subregulation (2) shall be equipped with at least one braking system.

(4) All braking systems required by this regulation shall be efficient and shall be kept in proper working order.

(5) For the purposes of subregulation (4), a braking system shall be deemed not to be efficient if the brake operates directly on the tyre of any wheel.

36. Any constable in uniform is hereby empowered and shall be permitted by the owner or other person in charge of any cycle to test and inspect the brakes of the cycle, either on a road or on any premises where the cycle is. Such a test and inspection shall not be carried out on any premises where the cycle is, unless—

Constable may test cycle brakes. [177/1956].

- (a) the cycle has been involved in an accident;
- (b) the test and inspection are carried out within 48 hours of the accident; and
- (c) the owner of the premises consents thereto.

37. No parent, guardian or any other person having legal custody of a child or young person below the age of 16 years shall knowingly permit such child or young person to ride on a road a cycle which does not comply with any of the provisions of this Part.

Liability of parents and guardians. [177/1956].

PART VII

USE OF MOTOR VEHICLES

38. Every driver of a motor vehicle shall comply with the following rules:

Rules to be observed by drivers. [177/1956 39/1957 197/1999 34/2003].

Rule

1. He shall not cause the motor vehicle to travel backwards for a greater distance or time than may be requisite for the safety or convenience of the occupants of the motor vehicle and of the passengers and other traffic on the road.

Travelling backwards.

In the City of Port-of-Spain or the City of San Fernando or the Boroughs of Arima, Chaguanas and Point Fortin he shall not cause the motor vehicle to travel backwards at the junction of any roads or round a corner.

2. He shall not, when on the motor vehicle, be in such a position that he cannot have full control over the same, or that he cannot obtain a full view of the road and traffic ahead of the motor vehicle.

Full control and view to be maintained.

LAWS OF TRINIDAD AND TOBAGO

154

Chap. 48:50

Motor Vehicles and Road Traffic

[Subsidiary]

Motor Vehicles and Road Traffic Regulations

Brakes to be applied and engine stopped on quitting motor vehicle.

3. He shall before quitting the motor vehicle stop the engine and apply the brakes.

Restrictions as to sitting by driver.

4. In the case of goods vehicles and public service vehicles, not more than one person shall sit by the side of the driver unless such vehicle has been certified by a Transport Officer to have been constructed for the purpose of accommodating more than one person beside the driver.

No person shall sit on the right-hand side of the driver of any motor vehicle unless such motor vehicle has been constructed with a left-hand drive.

To keep to the left. [197/1999].

5. (1) He shall keep the motor vehicle on the left of the road unless prevented by some sufficient cause save where the road is wide enough to accommodate three motor vehicles abreast and is marked off by the competent authority with a centre line, allowing vehicles occupying the centre to turn right.

To keep on the left on meeting other traffic.

(2) When meeting other vehicles he shall keep as close as possible to the left or near side of the road.

Overtaking.

(3) When overtaking other vehicles he shall keep to the right or off side of such other vehicles.

Being overtaken.

(4) When being overtaken by other vehicles he shall drive as close to the side of the road as possible so as to allow such other vehicles to pass, and in all cases he shall drive so as to give as much space as possible for the passing of other traffic and shall not speed abreast any vehicle when such vehicle is overtaking him.

Cutting in.

(5) He shall not drive so as to overtake other traffic unless he has a clear and unobstructed view of the road ahead and he shall not overtake such other traffic unless he sees that the road ahead is clear for a sufficient distance to enable him to overtake and get back to his proper side before meeting any traffic coming from the opposite direction.

LAWS OF TRINIDAD AND TOBAGO

Motor Vehicles and Road Traffic

Chap. 48:50

155

Motor Vehicles and Road Traffic Regulations

[Subsidiary]

(6) He shall not overtake other traffic when rounding a corner or when roads intersect or fork or where the road passes over the brow of a hill or over a humpbacked bridge or in any other circumstances where the driver cannot see sufficiently far ahead to overtake with safety.

Corners.

(7) He shall not cross a road or turn in a road or proceed from one road into another road, or drive from a place which is not a road into a road, or from a road into a place which is not a road unless he can do so without obstructing any other traffic on the road, and for this purpose he shall be held to be obstructing other traffic if he causes risk of accident thereto.

Crossings.

(8) When turning from one road into another road to the left he shall keep as close as possible to the left side of each road.

Turning to left.

(9) When turning from one road into another road to the right he shall drive round the point of intersection of the two roads, and shall keep as close as possible to the left side of each road.

Turning to right.

(10) He shall not park his motor vehicle within a distance of nine metres from any corner or road intersection or nearer thereto than the distance indicated by the appropriate traffic sign, if any.

Stopping at corners.

(11) He shall not draw up the motor vehicle alongside any other motor vehicle nor shall he back the motor vehicle to the kerb stone of any foot-path or to the side of any road except for the purpose of turning.

Drawing up alongside other motor vehicles.

(12) He shall not draw up his motor vehicle on any road or leave his motor vehicle standing on any road, within three metres of a fire hydrant.

Drawing up and standing alongside of fire hydrant.

(13) He shall not draw up his motor vehicle or permit it to remain on either side of any road, within three metres of the frontage of any Fire Brigade Station.

6. He shall not negligently or wilfully prevent, hinder or interrupt the free passage of any vehicle, person or animal,

Obstruction.

LAWS OF TRINIDAD AND TOBAGO

156

Chap. 48:50

Motor Vehicles and Road Traffic

[Subsidiary]

Motor Vehicles and Road Traffic Regulations

and shall not allow such motor vehicle and any trailer drawn thereby to stand in such road so as to cause any unnecessary obstruction thereto.

Turnings and crossroads.

7. (1) He shall, when approaching turnings and cross roads or coming from any private road or place to any public road, slow down and make the appropriate traffic signal.

(2) He shall, when turning across traffic or turning to the right, slow down and make the appropriate traffic signal.

(3) He shall, when about to stop or slow down the vehicle on any public road, do so gradually and make the appropriate traffic signal.

(4) He shall, when quitting any place at which his vehicle has been stationary, make the appropriate signal.

Traffic signals.

8. He shall, when using a motor vehicle on any road, make the following traffic signals:

- (a) when about to slow down or stop, he shall extend the right arm and hand horizontally with the palm of the hand turned downwards and shall move the arm slowly and repeatedly downwards and upwards keeping it below the level of the shoulder;
- (b) when about to turn across traffic or to turn to the right he shall extend the right hand and arm horizontally, palm turned to the front or if the motor vehicle is fitted with direction indicators the driver shall signal with the indicators fitted on the offside of the vehicle;
- (c) when acknowledging a signal indicating that the driver of a vehicle proceeding in the same direction wishes to pass he shall extend the right arm and hand below the level of the shoulder and move them backwards and forwards;
- (d) when about to turn to the left he shall extend the right arm and rotate it from

the shoulder in an anti-clockwise direction, or if the motor vehicle is fitted with direction indicators the driver shall signal with the indicator on the near side of the vehicle.

In no case shall the required traffic signal be given by the driver of a motor omnibus by means of a dummy arm unless the construction of the motor omnibus and the position of the driver's seat are such as to render it impossible for the driver to make such signal with his arm.

Further, in the case of a motor vehicle with left-hand steering, he shall, when using the vehicle on any road, make the following traffic signals:

- (i) when about to slow down or stop, he shall extend the left arm and hand horizontally with the palm of the hand turned downwards and shall move the arm slowly and repeatedly downwards and upwards keeping it below the level of the shoulder;
- (ii) when about to turn across traffic or to turn to the right, he shall extend the left arm and rotate it from the shoulder in a clockwise direction or, if the motor vehicle is fitted with direction indicators, the driver shall signal with the indicator fitted to the offside of the vehicle;
- (iii) when about to turn to the left, he shall extend the left hand and arm horizontally, palm turned to the front, or if the motor vehicle is fitted with direction indicators, the driver shall signal with the indicator on the near side of the vehicle.

LAWS OF TRINIDAD AND TOBAGO

158

Chap. 48:50

Motor Vehicles and Road Traffic

[Subsidiary]

Motor Vehicles and Road Traffic Regulations

Traffic directions.

9. He shall conform to the rules of the road in regard to all kinds of traffic and shall comply with the lawful directions of any constable or Transport Officer charged with the regulation of traffic. He shall give the following signals for the purpose of indicating the direction in which he wishes to proceed:

- (a) when it is proposed to go straight ahead, raise the hand towards the shoulder, and move the forearm well forwards and then back in a vertical plane, making the movement sufficiently pronounced to be easily seen by the constable;
- (b) when about to turn to the left he shall extend the right arm and rotate it from the shoulder in an anti-clockwise direction;
- (c) when it is proposed to turn to the right, extend the right arm and hand with the palm turned to the front, and hold them rigid in a horizontal position straight out from the off side of the vehicle. (This signal may be used in any circumstances when it may be necessary to convey the warning to traffic following behind that it is dangerous to overtake).

In the case of a motor vehicle with left-hand steering which is not fitted with direction indicators, he shall—

- (i) when about to turn to the left, extend the left arm and hand with the palm turned to the front and hold them rigid in a horizontal position straight out from the near side of the vehicle;
- (ii) when it is proposed to turn to the right, extend the left arm and rotate it from the shoulder in a clockwise direction.

Slow moving traffic.

10. Slow moving traffic shall keep as much to the left as possible at all times, and unladen vehicles shall give way to laden vehicles.

11. He shall, when about to stop the motor vehicle on any road, draw up as close as possible to the side of the road so as to allow a clear roadway for passing traffic; and shall remove the motor vehicle at the request of any constable when it is placed in such a position as to cause or be likely to cause obstruction on any road. He shall not draw up a vehicle or animal on a road in such manner as to obstruct a vehicular entrance to any premises. He shall not draw up the motor vehicle on a road in such a manner as to prevent or hinder the drivers of other vehicles complying with the directions of any traffic sign. He shall not leave the motor vehicle drawn up on any public road for an undue length of time having regard to all the circumstances of the case, including the amount of traffic which is at the time, or which might reasonably be expected to be, on the road.

Drawing up at side of road.

12. (1) He shall carry attached to the motor vehicle a horn or other instrument capable of giving audible and sufficient warning of its approach or position and he shall not himself sound or allow any other person to sound such horn or other instrument except for the purpose of giving reasonable and necessary warning of the approach or position of the motor vehicle.

Horns, etc.

(2) He shall not himself sound or allow any other person to sound such horn or other instrument between the hours of 9.00 p.m. and 5.30 a.m. in any Municipal area, and also in any other area in Trinidad and Tobago in respect of which the Licensing Authority shall issue a prohibition notice to that effect in the *Gazette*.

(3) The Licensing Authority shall have power at any time to prohibit the use of any horn or instrument, the use of which for the purpose authorised in this regulation is likely to cause annoyance to the general public.

(4) Every horn or other instrument used for the purposes authorised shall either be of a kind which has been approved by the Licensing Authority generally as proper to

LAWS OF TRINIDAD AND TOBAGO

160

Chap. 48:50

Motor Vehicles and Road Traffic

[Subsidiary]

Motor Vehicles and Road Traffic Regulations

be used on motor vehicles or which has been approved by him in a special case on the application of the owner of the motor vehicle.

(5) Any horn or other instrument which has been approved by the Licensing Authority for use on motor vehicles shall not be used on any other class of vehicles.

Sparks, smoke, vapour, lubricating oil.

13. He shall not permit sparks, smoke or visible vapour of any avoidable nature which would cause annoyance or danger to the public to come from any motor vehicle in his charge on or near any public road and shall take proper precautions to prevent the unnecessary discharge of lubricating oil on any road.

Stopping of motor vehicle at request of constable, or person in charge of horse. [197/1999].

14. He shall, on the request of any constable in uniform, or of any person having charge of a horse or any other animal, or if any such constable or Transport Officer or person shall put up his hand as a signal for that purpose, cause the motor vehicle to stop and to remain stationary so long as may be reasonably necessary.

Projections. [197/1999].

15. He shall not carry on the motor vehicle or trailer, or being the owner of any motor vehicle or trailer shall not suffer or permit to be carried thereon, any tree, timber or iron beam or any lumber or other matter or thing projecting on either side of such motor vehicle or trailer more than three hundred millimetres beyond the plane of the wheels of such motor vehicle or trailer, or projecting more than one and a half metres in front or behind, or in such a manner as to obstruct, endanger or interfere with traffic, nor any load in such manner that the width of such load together with the overall width of the vehicle shall exceed two and a half metres. First Division Police Officers in charge of divisions may grant permits for the transport over any road, within stated hours, by a stated route and under stated conditions, of articles the transport of which would otherwise infringe the provisions of this regulation. Such permits shall be carried on the motor vehicle and shall be produced by the driver at the request of any Police Officer or Transport Officer. Any motor vehicle operating

LAWS OF TRINIDAD AND TOBAGO

Motor Vehicles and Road Traffic

Chap. 48:50

161

Motor Vehicles and Road Traffic Regulations

[Subsidiary]

under the authority of any such permit shall carry by day a white flag and by night a red lamp affixed at the extreme rear end of the load.

16. He shall not allow the motor vehicle to be overcrowded with persons.

17. He shall not allow any person to stand in or on a goods vehicle, agricultural trailer or trailer or on the tray or platform thereof whilst the vehicle is in motion, or to be carried in such a position that danger is caused or likely to be caused to such person or any other person, notwithstanding any permission granted by the Licensing Authority for the conveyance of persons.

18. He shall not leave or permit to be left on any public road any motor vehicle which has broken down without taking the requisite steps to indicate its presence and position by lighting or otherwise to other persons using the road, and shall take immediate steps to have it removed as near to the left of the road as possible.

19. He shall on the approach of any engine or other apparatus of the Fire Services proceeding to and from a fire or suspected fire, or Police vehicles, Defence Force vehicles, Ambulances on emergency calls sounding their sirens or other warning instrument approved by the Licensing Authority, draw up close to the left-hand side of the road and stop, leaving the centre of the road for the passage of such vehicles, and he shall not stand abreast of any other vehicle.

20. He shall not, without the written permission of the Licensing Authority, tow anything except another motor vehicle in case of necessity, or a single registered trailer, except that in the case of an agricultural tractor he may tow not more than two trailers.

21. No motor vehicle shall tow any other vehicle unless the tow rope, chain or draw bar be so adjusted that the distance separating the nearest two points of the two vehicles shall not, except in the case of a pole trailer, exceed five metres, and the tow rope, chain or draw bar is easily distinguishable by other users of the road.

LAWS OF TRINIDAD AND TOBAGO

162

Chap. 48:50

Motor Vehicles and Road Traffic

[Subsidiary]

Motor Vehicles and Road Traffic Regulations

Filling petrol into motor vehicles.

39. Any person who fills petrol into any receptacle on or adjacent to any motor vehicle or into the tank of a motor vehicle while the engine is running, or while any light, other than an electric light, is alight on the vehicle, and any person who smokes or lights a match or exposes a naked light in close proximity while petrol is being so filled is guilty of an offence.

Reflecting mirror. [197/1999].

40. Every motor vehicle or trailer, other than a motorcycle, shall be equipped with the following:

- (a) a reflecting mirror, so constructed and fitted to the motor vehicle as to enable the driver of such motor vehicle to be or become aware of the presence in the rear thereof of any other vehicle, the driver of which is desirous of passing such motor vehicle;
- (b) a side mirror fitted on either side of the vehicle.

Fittings and equipment to be properly adjusted.

41. No part of the fittings, accessories or other equipment of any motor vehicle shall be so arranged or fixed as to be capable of being displaced by the motion of travel in a manner which causes the permitted dimensions of such vehicle to be exceeded.

Load to be properly secured.

42. In the case of goods vehicles the load shall be properly secured in such a manner as effectively to prevent the displacement of any portion thereof by the motion of travel. Any tarpaulin or other covering used for the protection of the load shall be adjusted so as to fit closely to the load or vehicle and shall be properly secured by ropes or other fastenings so as to prevent flapping or other displacement of such covering while the vehicle is in motion.

Noisy motor vehicles.

43. Any person driving or in charge of a motor vehicle which causes a loud noise to the annoyance or disturbance of any person is guilty of an offence under these Regulations.

Tyres.

44. (1) All tyres of a motor vehicle or trailer shall at all times be maintained in such condition as to be free from any defect which might in any way cause damage to the surface of the road, or danger to persons in or on the vehicle or to any persons using the road. A

LAWS OF TRINIDAD AND TOBAGO

Motor Vehicles and Road Traffic

Chap. 48:50

163

Motor Vehicles and Road Traffic Regulations

[Subsidiary]

person shall not be convicted under this regulation if he proves to the satisfaction of the Court that he could not by reasonable diligence have become aware of the defect.

(2) Any constable may require the driver of a motor vehicle, any of the tyres of which appears to the constable to be defective, to proceed to the nearest Police Station for examination and if the driver refuses to do so the motor vehicle may, at the expense and risk of the owner, be detained and taken to the said station or to a place for safe keeping until such request is complied with.

45. The glass windshield of any motor vehicle imported into Trinidad and Tobago after 31st December 1937 shall be made of safety glass.

Safety glass windshield.

46. An effective wiper shall be provided on the glass windshield of a motor vehicle.

Windshield wiper.

47. No person, other than the driver, whilst travelling in a motor vehicle shall make any traffic signal.

Traffic signal.

48. Whenever any constable or Transport Officer on point duty gives a traffic control signal to enable any vehicle to proceed in an indicated direction, no cyclist or pedestrian shall proceed across the current of traffic consequent upon such signal, or loiter in the roadway, or otherwise impede any vehicle from proceeding in the direction indicated.

Cyclists and pedestrians to comply with traffic control signal. [197/1999].

49. No musical instrument shall be played, no noisy instrument shall be played or operated in any motor vehicle, whilst in motion, except on the written permission of the Licensing Authority; and any person who plays or operates any such instrument in contravention of this regulation and the driver of the vehicle who permits such instrument to be played or operated is each guilty of an offence against this regulation.

Prohibition on playing of musical or noisy instruments in a motor vehicle.

PART VIII

USE OF VEHICLES OTHER THAN
MOTOR VEHICLES AND OF ANIMALS

Application of certain provisions of Part VII to drivers and riders of vehicles other than motor vehicles, and of animals. [177/1956].

50. (1) The following provisions of Part VII of these Regulations shall apply in respect of the persons specified below in this regulation as they apply in respect of the drivers of motor vehicles, that is to say:

- (a) regulation 38 rule 5(1), (2), (5) to (9), and rules 6, 9, 11, 12, 15 and 20 shall apply in respect of any person driving, riding, drawing or propelling any vehicle other than a motor vehicle, and in respect of any person riding any animal on any road;
- (b) regulation 38 rule 1, rule 5(10) and (13), rule 17 and regulation 47 shall apply in respect of any person driving any vehicle drawn by an animal on any road;
- (c) regulation 38 rule 5(11) shall apply in respect of any person driving any vehicle drawn by an animal, in respect of any person drawing or propelling a cart, and in respect of any person riding an animal on any road;
- (d) regulation 38 rule 2 and rule 7(1) to (4) shall apply in respect of any person driving any vehicle drawn by an animal, and in respect of any person riding a cycle or an animal on any road;
- (e) regulation 38 rules 14 and 19, and regulations 42, 43 and 49 shall apply in respect of any person driving any vehicle drawn by an animal, and in respect of any person drawing or propelling a cart on any road;
- (f) regulation 44 shall apply in respect of any person riding a cycle on any road,

and references in those provisions to motor vehicles, drivers and driving shall be construed accordingly.

(2) In this regulation “cart” means any hand cart, dray, van, wagon, truck, car, sledge, barrow and any other vehicle drawn or propelled by hand and used or intended to be used for the carrying of or conveyance of any goods, wares or other burden whatsoever, but does not include a motor vehicle.

51. The driver of any vehicle drawn by an animal and the rider of any cycle or animal on any road shall make the following traffic signals for the information of traffic or of any constable charged with the regulation of traffic:

Traffic signals.
[177/1956].

- (a) when about to slow down or stop, he shall extend the right arm and hand horizontally with the palm of the hand turned downwards and shall move the arm slowly and repeatedly downwards and upwards keeping it below the level of the shoulder;
- (b) when about to turn across traffic or to turn to the right he shall extend the right hand and arm horizontally, palm turned to the front;
- (c) when acknowledging a signal indicating that the driver or rider of a vehicle or the rider of an animal proceeding in the same direction wishes to pass, he shall extend the right arm and hand below the level of the shoulder and move them backwards and forwards;
- (d) when about to turn to the left he shall extend the right arm and rotate it from the shoulder in an anti-clockwise direction;
- (e) when he proposes to go straight ahead, he shall raise the right hand towards the shoulder, and move the forearm well forwards and then back in a vertical plane, making the movement sufficiently pronounced to be easily seen.

52. No person shall drive, ride, draw or propel a vehicle other than a motor vehicle (in respect of which similar provision is made in section 71 of the Act) or ride any animal on any road recklessly,

Reckless driving.
[177/1956
39/1957].

LAWS OF TRINIDAD AND TOBAGO

166

Chap. 48:50

Motor Vehicles and Road Traffic

[Subsidiary]

Motor Vehicles and Road Traffic Regulations

or at a speed or in a manner which is dangerous to the public, having regard to all the circumstances of the case, including the nature, condition and use of the road, and the amount of traffic which is actually at the time, or which might reasonably be expected to be on the road.

Careless driving.
[177/1956
39/1957].

53. No person shall drive, ride, draw or propel a vehicle other than a motor vehicle (in respect of which similar provision is made in section 71 of the Act) or ride any animal on any road without due care and attention or without reasonable consideration for other persons using the road.

Driving or riding while under influence of drink.
[177/1956].

54. No person shall ride a cycle or drive a vehicle drawn by an animal on any road while he is under the influence of drink or a drug to such an extent as to be incapable of having proper control of the cycle or vehicle, as the case may be.

Control of animal drawing vehicle.
[177/1956].

55. No person driving or in charge of any vehicle drawn by an animal on any road shall ride on any part of the vehicle or on the shafts thereof, or on the animal, without having and holding the reins, nor be at such distance from such vehicle as not to have complete control over the animal drawing the same.

Control of cattle.
[177/1956].

56. (1) No person shall drive any cattle furiously on any road.

(2) No person shall load or unload or attempt to load or unload any cattle in or upon any road from any vehicle without sufficient assistance to prevent any of such cattle from breaking loose or from doing mischief.

(3) No person shall allow any cattle to break loose on any road.

(4) No person, not being a person employed by the owner thereof to drive the same, shall run after any animal on any road, or by shouting or making a noise or in any other manner frighten any cattle which may have broken loose on any road.

LAWS OF TRINIDAD AND TOBAGO

Motor Vehicles and Road Traffic

Chap. 48:50

167

Motor Vehicles and Road Traffic Regulations

[Subsidiary]

(5) No person shall by negligence or ill-usage in driving any cattle on any road cause injury to be done by such cattle.

(6) No person shall allow any cattle to wander, stray or be tethered on any road.

(7) In this regulation “cattle” includes sheep, goats and swine.

57. No person shall wilfully drive, ride, draw or propel a vehicle or ride an animal upon any footpath or pavement by the side of any road made or set apart for the use or accommodation of pedestrians.

Driving or riding on the footpath. [177/1956 39/1957].

PART IX

**PUBLIC SERVICE VEHICLES—
CONSTRUCTION AND MAINTENANCE**

MOTOR OMNIBUSES

58. All bodies of motor omnibuses shall be of first-class workmanship and be securely bolted and braced. Where it is necessary to extend the chassis frame the extension shall be inspected by a Transport Officer before the body is finally bolted and braced to the frame.

Body and chassis. [197/1999].

59. In the case of motor omnibuses, all curtains, or screens, or other devices for the protection of passengers from the weather shall be properly secured by straps or other fastenings so as to prevent flapping or other displacement of such curtains, or screens, or other devices while the vehicle is in motion.

Curtains, screens, etc., to be properly fastened.

60. Motor omnibuses shall be so constructed that the height of the main floor measured at a certain point shall not exceed seven hundred and sixty millimetres measured vertically from the surface of the road when the vehicle is fully loaded. The Inspecting Engineer shall be empowered to pass vehicles as motor omnibuses with a greater height of flooring (but not exceeding the floor height passed by the Ministry of Transport) if he is satisfied as to the stability and safety of the vehicle.

Flooring. [197/1999].

LAWS OF TRINIDAD AND TOBAGO

168

Chap. 48:50

Motor Vehicles and Road Traffic

[Subsidiary]

Motor Vehicles and Road Traffic Regulations

Fittings for motor omnibuses.

Every motor omnibus shall be fitted with—

- (a) a device by which a passenger may signal to the driver or conductor when required;
- (b) a speedometer;
- (c) a fire extinguisher.

All such fittings shall be subject to the approval of the Transport Officer, and shall be kept in working order.

Seats, corridor and safety exits.

61. (1) *Seats*—The width between the backs of seats when the seats are placed lengthwise shall be not less than one and a half metres. When the seats are placed behind each other, the space between the seats shall be unobstructed, and the distance between the backs of two seats so placed shall be not less than seven hundred millimetres, and when seats are placed crosswise facing each other the unimpeded space between them shall be not less than six hundred and fifty millimetres and the depth of each seat shall be not less than three hundred and fifty-five millimetres. At least four hundred millimetres of unimpeded space shall be allowed for each passenger measured along each seat. The supports of all seats shall be firmly fixed in position.

(2) *Corridors*—Every motor omnibus registered after 31st December 1935, with seating accommodation for more than ten passengers, shall have an internal corridor of not less than four hundred millimetres in width, so arranged as to admit of easy access from within the vehicle to all seats; and no person shall stand on or move along the footboard outside any such vehicle whilst it is in motion.

(3) *Emergency Exit*—Every motor omnibus, the sides of which are enclosed, shall be fitted at the rear of the vehicle with an emergency door opening outwards, or other sufficient exit which shall be readily accessible from all seats; such door or exit shall be kept secured against use by any passenger, except in the case of an emergency.

Steps, etc.

62. No steps, footboard or running-board shall be allowed on the right or off side of any motor omnibus. Horizontal metal rails

LAWS OF TRINIDAD AND TOBAGO

Motor Vehicles and Road Traffic

Chap. 48:50

169

Motor Vehicles and Road Traffic Regulations

[Subsidiary]

spaced not more than two hundred and thirty millimetres apart shall run from end to end and from floor level to six hundred millimetres above the level of the seats. Such rails shall not be moveable.

63. Where running boards, steps or footboards are fitted to the left or near side of the omnibus these must be fitted with a toeguard at least one hundred millimetres above the running board, step or footboard and securely fastened to same. The length of this toeguard not to be less than one hundred and fifty millimetres longer than the outside diameter of the rear tyre and to be fitted equidistant from the centre of the rear wheel.

Toeguards.

64. The driver's seat shall not be less than six hundred millimetres wide, and shall be so constructed that there is a space of at least three hundred millimetres on each side of the steering column, the space between the rear lower part of the steering wheel and the top of the driver's seat (inclusive of any cushion) shall not be less than one hundred and eighty millimetres. This seat shall slope backwards with a rake of one hundred and twenty-five millimetres per metre measured horizontally, the distance between the back part of the steering wheel and the back of the driver's seat shall not be less than three hundred and thirty millimetres. The driver's seat shall be divided off from that of the person sitting beside him on his left by a wooden partition not less than seven hundred and sixty millimetres high measured from the floor, and extending from the front of the front seat to the dashboard. In any case this partition is to have a clearance of not less than fifty millimetres to the left of the extreme left lever controlled by the driver.

Driver's seat.

65. A fixed seat shall be provided for the conductor in every motor omnibus which shall not in any way interfere with the driver or passenger seating accommodation.

Conductor's seat.

66. Every motor omnibus with seating accommodation for more than ten passengers when in use on any road shall at all times carry a conductor in addition to a driver.

Motor omnibus to carry conductor.

LAWS OF TRINIDAD AND TOBAGO

170

Chap. 48:50

Motor Vehicles and Road Traffic

[Subsidiary]

Motor Vehicles and Road Traffic Regulations

The owner and driver shall both be liable if the motor omnibus is used in contravention of this regulation.

Front protection. **67.** Where passengers are carried on the left or near side of the driver's side, provision shall be made for a suitable guard, barrier or rail to be fitted so that, in the event of the omnibus stopping suddenly, the passenger or passengers cannot be thrown forward and out of the omnibus.

Internal height. **68.** The internal height measured in the centre line of a motor omnibus from floor to lower edge of hoop sticks or other projections on the ceiling shall not be less than one and a half metres.

Driver's uniform and badge. **69.** Every driver of a motor omnibus on a public road shall at all times—

- (a) wear his badge conspicuously and in such a manner that the whole of the writing thereon is distinctly legible;
- (b) be suitably attired and wear boots or shoes and a distinguishing cap and uniform to consist of a forage cap and a khaki or blue serge suit.

Special regulations for motor bus conductors. [9 of 1997]. **70.** Every conductor of a motor omnibus on a public road shall comply with the following regulations:

- (a) he shall not smoke after objection made by any passenger;
- (b) he shall not make use of any abusive language or insulting gestures;
- (c) he shall not call out to or otherwise importune any person to travel by any such omnibus;
- (d) he shall not ride otherwise than inside such omnibus except when collecting a fare;
- (e) he shall not permit more passengers than such omnibus is registered for to be carried in such omnibus. If there are passengers in excess, the conductor, or the driver when there is no conductor, shall at the request of any constable

in uniform eject the passengers being carried in excess, and on his refusal so to do the constable may arrest the conductor or the driver, as the case may be, and take such steps as may be necessary to prevent the vehicle from proceeding on its journey with such excess passengers. Three children, if they are each under the age of fifteen years, shall be counted as two passengers for the purposes of this paragraph;

- (f) he shall not permit luggage other than personal luggage to be carried on such omnibus, "Personal Luggage" means wearing apparel and such other personal requisities as are usually carried by a traveller for his comfort and convenience, and includes the receptacle in which such articles are being conveyed;
- (g) he shall not be under the influence of drink or drugs during his employment;
- (h) he shall at all times wear his badge conspicuously in such a manner that the whole of the writing thereon is distinctly legible;
- (i) he shall at all times be suitably attired and wear boots or shoes and a distinguishing cap and uniform, to consist of a forage cap and a khaki or blue serge suit.

71. Every person driving a motor omnibus on a road shall after quitting any stand or garage with passengers proceed direct to the place or places included in the route of such omnibus, and shall not delay in so doing, and shall not return to the place of departure after leaving it, except on the return journey.

Motor bus to proceed direct to destination.

72. The driver or conductor of a motor omnibus on any road shall not permit passengers to enter or leave such omnibus otherwise than by the rear or by the left or near side thereof.

Entering or leaving bus.

LAWS OF TRINIDAD AND TOBAGO

172

Chap. 48:50

Motor Vehicles and Road Traffic

[Subsidiary]

Motor Vehicles and Road Traffic Regulations

Licensing Authority may delegate his powers.

73. All acts and things required by this Part to be done by the Licensing Authority may be done by any person or persons to whom he may from time to time delegate all or any of his powers.

Motor omnibuses registered prior to 1st January 1935.

74. The Licensing Authority in his discretion need not enforce any or all of these Regulations in respect of motor omnibuses that were registered as such prior to 1st January 1935.

Saving as to motor omnibus. [104/1982].

75. The Licensing Authority may in his discretion exempt motor omnibuses from any of the provisions of these Regulations having regard to—

- (a) the number of passengers or amount of load to be carried by such omnibuses;
- (b) the particular route on which or the type of service in which these omnibuses are to be used;
- (c) the safety and convenience of the public,

and in particular any such exemption may relate to the attendance of conductors.

PUBLIC SERVICE VEHICLES

Special regulations for drivers of public service vehicles. [197/1999].

76. The driver of a public service vehicle shall comply with the following regulations:

- (a) he shall not use a horn or other instrument for the purpose of calling passengers;
- (b) he shall not smoke after objection made by any passenger;
- (c) he shall not make use to any passenger of any abusive language or insulting gestures;
- (d) he shall not call out to or otherwise importune any person to travel by such public service vehicle;
- (e) he shall not loiter for the purpose of procuring passengers or otherwise;
- (f) he shall not, while waiting to pick up passengers, race his engine or make any loud or unnecessary noise with his engine;

- (g) he shall at the request of any passenger immediately stop in order to enable such passenger to alight; and when he is driving a motor omnibus in any area where stopping places are designated he shall not stop the motor omnibus to pick up or set down passengers elsewhere than at a stopping place marked as such by signboard or other device, nor shall he stop at any such stopping place unless passengers are waiting to be picked up or desire to alight; and when stopping to pick up or set down passengers he shall not cause any obstruction to the ordinary traffic on the road;
- (h) he shall not in the City of Port-of-Spain, the City of San Fernando and the Boroughs of Arima, Chaguanas and Point Fortin and in Princes Town draw up his omnibus on a road other than at a public stand appointed under the Act, except for the purpose of taking on or discharging passengers;
- (i) he shall maintain the public service vehicle in a clean and sanitary condition;
- (j) he shall carry at least one spare inflated tyre fixed to the rim, spare wheel or other device, capable of being fitted to a wheel or axle.

77. The driver of a public service vehicle and the conductor of a motor omnibus wherein any property is left shall within twenty-four hours deposit such property, if not sooner claimed, at the police station nearest to his residence. Lost property.

78. No owner, driver or conductor of a public service vehicle plying for hire or any other person shall speak, make any noise or sound any instrument in order to attract the attention of the public or of a possible passenger; or by troublesome and frequent demands or by persistent following hold out the vehicle for hire to the public in such a manner as to constitute a nuisance, or act in any way so as to cause annoyance or inconvenience to any person. Touting.

LAWS OF TRINIDAD AND TOBAGO

174

Chap. 48:50

Motor Vehicles and Road Traffic

[Subsidiary]

Motor Vehicles and Road Traffic Regulations

Attire of taxi driver.

79. Every driver of a taxi on a public road shall be suitably attired.

Advertisement.

80. No owner or driver of a taxi shall place or suffer to be placed any printed, written or other matter by way of advertisement on any side window of the taxi.

Refusal to hire motor vehicle. [9 of 1997].

81. (1) The driver of a taxi shall not without reasonable excuse—

- (a) refuse to be hired when the taxi is standing on a public stand; or
- (b) refuse or neglect to drive the taxi to any accessible place indicated by the hirer: Provided that the whole journey, out and return, does not exceed thirty-five kilometres; or
- (c) refuse or neglect to carry such number of passengers, not exceeding the number specified in the motor vehicle registration, as he may be required to carry by the hirer; or
- (d) refuse or neglect to accept with a hirer, a reasonable amount of luggage.

(2) Where a taxi is at the head of a rank at a public stand, the driver thereof shall, except for good and substantial cause, the proof whereof shall lie on him, remain standing by, or seated in, the taxi.

82. (*Repealed by LN 197/1999*).

83. (*Deleted by LN 34/2003*).

Right to demand fare.

84. (1) The driver or conductor of any public service vehicle shall have the right to demand his fare of any person employing him or intending to travel in such vehicle, upon such person entering the vehicle or ordering him to wait or to drive further, and may refuse to convey any such person who does not comply with such demand, and may require any constable to remove from the vehicle any person so refusing to pay his fare.

(2) Every driver or conductor of a public service vehicle who demands more than his legal fare, and every person who refuses or omits to pay his legal fare, and every person who resists or obstructs a constable in the performance of his duty under this regulation is liable on summary conviction to a penalty not exceeding one hundred and fifty dollars.

PART X

*RESTRICTIONS RELATING TO MOTOR OMNIBUSES

85. (1) A motor omnibus shall be permitted to ply for hire or reward only on the route or routes specified in the licence issued in respect thereof and shall not be permitted to ply for hire or reward on any route not specified therein without a special permit from a Transport Officer.

Omnibus routes. [197/1999].

(2) If the driver of a motor omnibus uses any route other than that specified in the licence or permit for the purpose of plying for hire or reward, or of conveying any passenger, he shall be guilty of an offence.

86. Every licence for a motor omnibus shall specify the route or routes and the limits thereof on or along which the vehicle is permitted to ply for hire or reward.

Routes to be specified on licence.

87. A Transport Officer may in his discretion issue occasional special permits to enable any motor omnibus to operate on special occasions on a route other than that for which the motor omnibus is licensed upon payment of a fee of twenty-five cents. Such permit shall be valid for the period therein stated but not exceeding seven days. The driver of the motor omnibus shall retain the permit in his possession and produce the same for inspection to any police officer on demand.

Special permits. [197/1999].

88. }
to } (*Repealed by LN 197/1999*).
90. }

*See Note on Application at page 3.

LAWS OF TRINIDAD AND TOBAGO

176

Chap. 48:50

Motor Vehicles and Road Traffic

[Subsidiary]

Motor Vehicles and Road Traffic Regulations

Reconsideration of Licensing Authority's decision. [197/1999].

91. Any person aggrieved by any decision of the Licensing Authority or of a Transport Officer shall have the right to submit his application by way of appeal to the Trinidad Transport Board for further consideration.

PART XI

RULES FOR PARKING OF VEHICLES

No lighted lamps on motor vehicles required when in parking places and public stands. Third Schedule.

92. Any motor vehicle while waiting at the Parking Places specified in the Third Schedule shall be parked in the prescribed manner only, and at night when so parked shall not be required to carry any lighted lamps.

Rules for parking of taxis.

93. The taxis shall stand in line commencing five metres from the near kerb of any intersecting road unless otherwise provided and not less than one metre nor more than one and a half metres apart from each other; but where taxis are required or permitted to stand alongside each other they shall so stand not less than three hundred millimetres apart, and not less than one metre between the lines.

Taxis leaving stands.

94. (1) Taxis standing for hire in stands shall leave such stands for the purpose of answering calls according to their priority of position in such stands and not otherwise.

(2) On the departure of any taxi standing for hire in any such stands the taxi next in rear thereto shall move forward and occupy the vacant place, and in like manner other taxis in rear shall move forward in the line and occupy the vacant spaces immediately in front of them.

Parking of taxis.

95. No vehicles other than taxis may park in Public Stands appointed for taxis.

Alignment of omnibuses.

96. Motor omnibuses shall stand in line not less than one metre nor more than one and a half metres apart from each other.

Omnibuses leaving stands.

97. On the departure of any motor omnibus standing for hire in any such stands the motor omnibus next in rear thereto

shall move forward and occupy the vacant place and in like manner other motor omnibuses in rear shall move forward in line and occupy the vacant spaces immediately in front of them.

98. (1) No vehicles other than motor omnibuses may park in Public Stands appointed for motor omnibuses. Parking. [233/1951].

(2) No vehicle may park at any time on the Golden Grove Road, Arouca, within four hundred and sixty metres of any part of the Golden Grove Prison.

99. }
100. } (*Repealed by LN 197/1999*).

PART XII

TRAFFIC LIGHT SIGNALS

101. The Minister may erect and maintain light signals for the control of vehicular traffic subject to the following provisions: Licensing Authority to erect and maintain light signals. [83/1952 177/1956 197/1999].

- (a) at least three lights shall be used facing the stream of traffic which the signal is intended to control, one red, one amber and one green;
- (b) the lamps showing the coloured lights aforesaid shall be arranged vertically, the lamp showing a red light being the uppermost and that showing a green light the lowermost;
- (c) each lamp shall be separately illuminated and the effective diameter of the lens thereof shall not be less than two hundred millimetres;
- (d) the height of the centre of the green lens from the carriageway shall be not less than one and a half metres;
- (e) the edges of the lenses shall not be more than three hundred and sixty millimetres apart;

(f) }
(g) } (*Deleted by LN 197/1999*).

LAWS OF TRINIDAD AND TOBAGO

178

Chap. 48:50

Motor Vehicles and Road Traffic

[Subsidiary]

Motor Vehicles and Road Traffic Regulations

Significance of
light signals.
[83/1952
177/1956
197/1999].

102. The significance of the light signals shall be as follows:

- (a) the red signal shall be taken as prohibiting vehicular traffic to proceed beyond the stop line on the carriageway provided in conjunction with the signals;
- (b) the amber signal in combination with the red signal shall be taken to denote an impending change in the indications given by the signal from red to green but shall not be taken to alter the prohibitory significance of the red signal;
- (c) the full green signal shall be taken to indicate that vehicular traffic may pass the signal and proceed with due regard to the safety of other users of the road and subject to the directions of any police constable or other duly authorised person who may be engaged in the regulation of traffic;
- (d) the full amber signal shown alone shall be taken as prohibiting vehicular traffic from proceeding beyond the stop line except in the case of any vehicle which when the signal first appears is so close to the said line that it cannot safely be stopped before passing the line;
- (e) the green arrow signal shall be taken to indicate that vehicular traffic may pass the signal and proceed with due regard to the safety of other users of the road in the direction indicated by the signal;
- (f) the combination of the red signal and the green arrow signal shall be taken to indicate that vehicular traffic is prohibited from proceeding beyond the stop sign on the carriageway provided in conjunction with the signal except in the case of the vehicles proceeding in the direction indicated by the green arrow signal;
- (g) the combination of the red signal and the amber arrow shall be taken to indicate that vehicular traffic is prohibited from proceeding beyond the

stop sign on the carriageway provided in conjunction with the signals except when proceeding in the direction indicated by the arrow and that vehicles so proceeding shall give way to vehicles proceeding across their path;

- (h) the flashing red signal shall be taken to indicate that vehicular traffic may proceed with extreme caution beyond the stop line on the carriageway save that vehicles so proceeding shall give way to vehicles proceeding in pursuance of the flashing amber signal referred to in paragraph (i);
- (i) the flashing amber signal shall be taken to indicate that vehicular traffic may proceed with extreme caution beyond the stop line on the carriageway and such vehicles shall have the right of way over vehicular traffic proceeding in pursuance of the flashing red signal referred to at paragraph (h).

103. (Repealed by LN 197/1999).

104. (1) Light symbols may be used for the purpose of indicating to pedestrians the period during which it is desirable that they should or should not cross the carriageway.

“Cross” and
“Don’t Cross”
signals.
[83/1952
197/1999].

(2) Such light symbols shall be used in conjunction with those light symbols used for the control of vehicular traffic.

(3) Where such symbols are used in accordance with subregulations (1) and (2), they shall consist of—

- (a) a red standing man or red palm or the words “DON’T WALK” illuminated in red that shall be taken as indicating to pedestrians the period during which they should not cross the carriageway;
- (b) a flashing red standing man or the flashing words “DON’T WALK” illuminated in red that shall be taken as indicating to pedestrians that they should not begin to cross the carriageway;

LAWS OF TRINIDAD AND TOBAGO

180

Chap. 48:50

Motor Vehicles and Road Traffic

[Subsidiary]

Motor Vehicles and Road Traffic Regulations

(c) a lunar and white walking man or the word “WALK” illuminated in lunar white that shall be taken to indicate to pedestrians the period during which they should cross the carriageway.

(4) *(Deleted by LN 197/1999).*

Inoperative traffic lights. [197/1999]

104A. Where traffic light signals under this Part are rendered inoperative or cease to function in the proper manner, motorists at any affected carriageway or intersection shall stop at the stop line and proceed only when safe to do so, exercising extreme caution at all times.

PART XIII

SPECIAL TRAFFIC DIRECTIONS

Traffic at dual carriageways. [39/1957 197/1999].

105. Wherever dual carriageways are provided along a public road all vehicles shall proceed along or keep to the left hand carriageway and shall keep to the left side of the left hand carriageway except when overtaking. Any vehicle entering such road from a side road or intersecting road will bear to the left and if desiring to cross the road or to pass on to the further carriageway it will keep to the left of the traffic island situated opposite to the junction from which it has emerged and forming part of the central strip dividing the dual carriageway.

Traffic at roundabouts. [39/1957].

106. At any place where a traffic roundabout has been constructed and where such roundabout is indicated by traffic signs all vehicles will proceed in a clockwise direction only.

Traffic at crossroads. [177/1956 39/1957].

107. Any person who is driving a motor vehicle or who is driving or is in control of any other vehicle shall slow down when coming from any private road or place to any public road or when approaching any crossroads or road junction, and if on his near side of the road along which he is proceeding there is erected a traffic sign bearing the legend “Stop at Major Road Ahead” or “Stop—Major Road Ahead”, he shall stop his vehicle before reaching, and as near as possible to, the stop line and shall not move his vehicle or cause his vehicle to move to the crossroads or

road junction next ahead until he has satisfied himself that it is safe to do so and he shall then proceed slowly and give way to any traffic which may be on such crossroads or road junction.

108. *(Repealed by LN 197/1999).*

109. No person shall drive a lorry on High Street, in the City of San Fernando, between Cuenca Street and the Library Corner except for the purpose of delivering or removing goods within that area.

Restricting lorries on part of High Street.

110. No cart or handcart shall be allowed to be backed into any pavement within the City of San Fernando. All such carts shall be drawn up parallel to the pavements for the purpose of loading or unloading any goods, articles or things, such loading to be done by means of skids. This regulation shall not apply to that part of High Street between Pointe-a-Pierre Road and Penitence Street.

Parking of vehicles in San Fernando. [26/1957].

PART XIV

TAXIS

111. (1) No person shall drive on any road a taxi registered as such unless he is the holder of a taxi driver's licence issued to him by the Licensing Authority under these Regulations.

Taxi Drivers' licences. [4/1985 197/1999].

(2) Every application for a taxi driver's licence shall be in the form set out in the Fourth Schedule and shall be signed by the applicant. Duplicate photographs of the applicant of passport size, a Police Certificate of Character and his driving permit issued under the Act shall accompany each application.

Fourth Schedule.

(3) The Licensing Authority may refuse a taxi driver's licence to any applicant who fails to satisfy him that he is a fit and proper person to hold such a licence. Before refusing a licence the Licensing Authority shall inform the applicant of the grounds for the proposed refusal and shall consider any representations made in writing in support of his application within seven days thereafter. If the applicant notifies the Licensing Authority that he wishes to make oral representations and/or adduce witnesses in support of

LAWS OF TRINIDAD AND TOBAGO

182

Chap. 48:50

Motor Vehicles and Road Traffic

[Subsidiary]

Motor Vehicles and Road Traffic Regulations

his application the Licensing Authority shall hear such representations and/or witnesses or shall direct his Deputy or such other officer as he may appoint to hear and determine the matter in dispute. A taxi driver's licence may be refused notwithstanding that the applicant is the holder of a driving permit under the Act, but shall in no case be issued to an applicant who is not the holder of such a permit. The fee for a taxi driver's licence shall be ten dollars and shall be paid to the Licensing Authority before the licence is issued. The licence shall be in the form set out in the Fifth Schedule. A taxi driver's licence shall not be valid during any period in which the holder is not the holder of a driving permit under the Act, and is renewable every three years.

Fifth Schedule.

(4) On the grant of a taxi driver's licence there shall be issued to the holder thereof a badge on which is embossed the number of the licence and a photograph of the holder if the Licensing Authority provides such badge and/or photograph. Such badge shall be displayed therein at all times when any taxi of which such holder is the driver is standing, plying or being driven for hire, in such a manner as to be plainly and distinctly visible.

(5) An application for the grant or renewal of a taxi driver's licence and badge may be dealt with at any time within one month before the date on which the renewal of the taxi driver's licence and badge is to take effect.

Duplicate licences.

112. If the holder of a taxi driver's licence shall satisfy the Licensing Authority that the licence issued to him has been lost, destroyed or defaced and that he has not wilfully effected or been a party to such loss, destruction or defacement, it shall be lawful for the Licensing Authority to issue a duplicate licence. If the former licence has been defaced it shall be surrendered to the Licensing Authority prior to the issue of a duplicate licence. The provisions of regulation 111(3) shall apply in relation to duplicate licences and every such duplicate licence shall be endorsed as such by the Licensing Authority. The Licensing Authority shall not refuse to issue a duplicate licence on the ground that the applicant is not a fit and proper person to hold a licence except on facts which have come to his knowledge since the original licence was issued.

113. (1) The Licensing Authority may cancel any taxi driver's licence (which expression when hereinafter used shall include a duplicate licence) if the holder thereof is convicted of any offence against any of the regulations contained in this Part or if the Licensing Authority is satisfied that it was obtained by any false representation, or that the holder has ceased to be a fit and proper person to hold a taxi driver's licence. The Licensing Authority shall inform him of the substance of what is alleged against him and shall consider any explanations or representations made by him in writing in connection with such proposed cancellation within seven days thereafter. If the holder of the taxi driver's licence notifies the Licensing Authority that he wishes to make oral representation and/or adduce witnesses in connection with such proposed cancellation, the Licensing Authority shall hear such representations and/or witnesses or shall direct his Deputy or such other officer as he may appoint to hear and determine the matter in dispute. Cancellation of a taxi driver's licence may be effected by notice to the holder, and on such cancellation the holder shall forthwith surrender his licence and badge to the Licensing Authority. When the driving permit of any person has been cancelled under the Act it shall be in the discretion of the Licensing Authority to refuse any further taxi driver's licence to that person.

Cancellation of
Taxi Drivers'
licences.

(2) The holder of a taxi driver's licence shall surrender such licence and the badge issued therewith forthwith to the Licensing Authority on ceasing to be the holder of a driving permit issued under the Act.

(3) Whenever a taxi driver's licence and badge are surrendered for any reason by the holder thereof, the Licensing Authority shall refund to such holder the sum of eighty cents.

114. It shall be the duty of the holder of a taxi driver's licence to notify the officer in charge of the police station nearest his residence of any change in the particulars set out in his licence and to produce such licence to such officer. If required to do so by the officer, he shall sign a statement containing full

Changes in
particulars set
out in taxi
drivers' licences
to be notified.

LAWS OF TRINIDAD AND TOBAGO

184

Chap. 48:50 *Motor Vehicles and Road Traffic*

[Subsidiary]

Motor Vehicles and Road Traffic Regulations

particulars of the information given and the officer shall forward the licence and the particulars to the Licensing Authority who may make any necessary correction on the licence and return the same to the holder.

Production and inspection of taxi drivers' licences. [197/1999].

115. It shall be the duty of every taxi-driver to take all proper steps to preserve his licence and badge against loss, destruction or defacement, and to produce the same on demand for inspection by any member of a police service or any Transport Officer constituted by law in Trinidad and Tobago or by any passenger in any taxi of which he may be the driver.

Only *bona fide* passengers to be in taxis plying for or on hire in taxi stands.

116. (1) Whenever any taxi is on a taxi stand, or is plying for hire or is under hire, no person (other than the driver) shall be in the taxi unless he is a *bona fide* passenger.

(2) In this regulation, the expression "*bona fide* passenger" means a person (hereinafter referred to as "the hirer") who, on his own account or jointly with others, has hired the taxi for reward and any other person who has entered the taxi with the permission of the hirer.

(3) If the preceding provisions of this regulation are contravened, the driver of the taxi and the persons who were in the taxi in contravention of those provisions shall be deemed to have contravened these Regulations; and in any prosecution for any such contravention any person (other than the driver) proved to have been in the taxi who cannot give a good account of himself shall be deemed not to be a *bona fide* passenger.

No person to loiter on or about a taxi stand.

(4) If any person shall loiter on or about any taxi stand (whether in a vehicle or otherwise) and shall fail to give a good account of himself, he shall be deemed to have contravened these Regulations.

Taxi not to be used for indecent or immoral purpose.

117. A driver of a taxi shall not himself use, or knowingly permit the taxi to be used by any other person for any indecent or immoral purpose.

LAWS OF TRINIDAD AND TOBAGO

Motor Vehicles and Road Traffic

Chap. 48:50

185

Motor Vehicles and Road Traffic Regulations

[Subsidiary]

118. (*Repealed by LN 197/1999*).

119. The provisions of regulation 111(1) and of regulation 116 shall not apply in relation to any taxi when it is on a road or is being driven on a road for the purpose of test by any garage keeper or any employee of any garage keeper and is not being used for hire or reward. Exemption.

120. No person shall cause or permit a rented car to ply for hire on any road. Rented cars not to be used as taxis.

PART XV

MISCELLANEOUS

121. (1) No person shall drive or cause or permit any person employed by him or subject to his orders to drive any hiring car or motor omnibus, or any goods vehicle, continuously for more than five-and-a-half hours without at least a half hour intervening during which the driver can obtain rest and refreshment, nor for an aggregate of more than ten hours in any twenty-four-hour period, nor for more than fifty-six hours in any one week, and provided that the driver shall have at least ten consecutive hours for rest during such twenty-four-hour period and shall not be employed in any capacity by his employer for more than eleven hours during such twenty-four-hour period. Limitation of drivers' working hours.

(2) For the purposes of this regulation, a twenty-four-hour period shall be the period of time commencing from the hour at which the driver first took up work on any day to the corresponding hour on the following day.

122. The Licensing Authority, in his discretion, need not enforce any or all of the provisions contained in regulations 58 to 65, 67 and 68 of these Regulations, and the provisions of regulation 70(e) and (f) of these Regulations shall have effect in relation to any motor omnibus subject to any modification approved by the Licensing Authority and endorsed on the licence relating to such vehicle by such Authority or on his behalf. Discretionary powers of Licensing Authority.

LAWS OF TRINIDAD AND TOBAGO

186

Chap. 48:50 *Motor Vehicles and Road Traffic*

[Subsidiary]

Motor Vehicles and Road Traffic Regulations

Eastern Main
Road
Regulations.
[200/1951].

123. (1) No person shall, except for the purpose of taking up or setting down passengers, allow a vehicle to remain stationary at any time between the hours of 7.30 a.m. and 9.00 a.m. or between the hours of 4.00 p.m. and 5.30 p.m. on any day at any place on the following sections of road:

- (a) that portion of South Quay and the Eastern Main Road which lies between Piccadilly Street in the City of Port-of-Spain and Bushe Street at San Juan; and
- (b) that portion of the Eastern Main Road which lies between St. John's Road and Freeling Street at Tunapuna.

(2) No goods shall be loaded or unloaded from any vehicle at any place on the aforesaid sections of road at any time between the aforesaid hours; and the driver or person in charge of any vehicle on or from which any goods are loaded or unloaded in contravention of this regulation and any person assisting in such loading or unloading shall each be guilty of an offence against this regulation.

(3) No person shall drive an animal-drawn cart in an easterly direction along that section of the Eastern Main Road which lies between its junctions with the Old St. Joseph Road on the West and Leon Street on the East at any time between the aforesaid hours.

Eastern Main
Road, Demerara
Road, Aripo and
Heights of
Guanapo Roads.

124. No person shall, except for the purpose of taking up or setting down passengers, allow a vehicle, other than a vehicle belonging to the Government of the United States, to remain stationary at any time at any place on the following sections of roads:

- (a) that portion of the Eastern Main Road which lies between the thirty kilometres and the thirty-five kilometres marks;
- (b) the whole of Demerara Road;
- (c) that portion of the Aripo Road which lies between the zero and three-kilometre marks;

LAWS OF TRINIDAD AND TOBAGO

Motor Vehicles and Road Traffic

Chap. 48:50

187

Motor Vehicles and Road Traffic Regulations

[Subsidiary]

(d) that portion of the Heights of Guanapo Road which lies between the zero and four-kilometre marks.

125. (1) Between the hours of 7.00 a.m. and 9.00 a.m. and 4.00 p.m. and 6.00 p.m. daily no vehicle shall be drawn up and parked on the north side of the Western Main Road between Mucurapo Road on the East and the Diego Martin Road on the West.

Western Main Road.

(2) Between the aforesaid hours waiting will be permitted on the south side of the Western Main Road only.

126. No person shall, except for the purpose of taking up or setting down passengers, allow a vehicle to remain stationary at any time on that portion of the Chaguanas Road, between Endeavour Road on the East and the Caroni-Savannah Road on the West.

Chaguanas Road.
[43/1958].

127. Unless otherwise specifically provided, no person shall use or cause or permit to be used on any road a vehicle or trailer which does not comply with the Regulations—

Liability for contravention or failure to comply with Regulations.
[177/1956].

- (a) applicable to the class or description of vehicles to which the vehicle belongs as to the construction, weight and equipment thereof; or
- (b) as to the use or maintenance of any such vehicle or trailer or part thereof in a specified condition.

LAWS OF TRINIDAD AND TOBAGO

188

Chap. 48:50

Motor Vehicles and Road Traffic

[Subsidiary]

Motor Vehicles and Road Traffic Regulations

[11 of 1963
61/1979].

FIRST SCHEDULE

REPUBLIC OF TRINIDAD AND TOBAGO

(Regulation 4).

FORM 1

**FORM OF PARTICULARS TO BE GIVEN BY APPLICANT
FOR REGISTRATION OF A MOTOR VEHICLE**

No.

Motor Vehicles and Road Traffic Act, Ch. 48:50

1. Full Name of Owner 	
2. Postal Address of residence of Owner...	
3. Description or type of Vehicle 	
4. Type and Colour of Body and Seating Accommodation 	
5. Make of Car and year of Manufacture...	
6. Chassis Number... 	
7. Name of Company with which insured...	
8. Weight for Licensing Purposes 	
9. Whether intended for use as— (a) Private motor car; (b) Hiring car or taxi; (c) Motor omnibus or freight and passenger vehicle; (d) Motor lorry; (e) Goods vehicle; (f) Trailer; (g) Motorcycle.	
10. Particulars as to the position on the car in which it is proposed to place the plates forming the identification mark 	

.....
Date of Application

.....
Signature of Owner

N.B.—It is an offence under the Act to give any particulars which are not correct and you will be liable to prosecution if you do so.

LAWS OF TRINIDAD AND TOBAGO

Motor Vehicles and Road Traffic

Chap. 48:50

189

Motor Vehicles and Road Traffic Regulations

[Subsidiary]

FORM 2

(Regulation 13).

APPLICATION FOR LICENCE FOR A MOTOR VEHICLE

Motor Vehicles and Road Traffic Act, Ch. 48:50

PARTICULARS

Full Name of Owner (Type or block letters)

Residential Address (Type or block letters)

Registered Letter, Identification mark and number

Make and Model of Vehicle

Whether intended for use as—

- (a) Private motor car
(b) Hiring car or taxi
(c) Motor omnibus or freight and passenger vehicle
(d) Motor lorry
(e) Goods vehicle
(f) Trailer
(g) Motorcycle

Weight for Licensing Purposes

Regular Omnibus Route

Motor Vehicles Inspector's Certificate No. Date

Insured with

Address

Number of Policy

Date Policy Expires

..... Signature of Owner

Date

N.B.—It is an offence under the Act to give any particulars which are false or in any respect misleading and you will be liable to prosecution if you do so.

LAWS OF TRINIDAD AND TOBAGO

190

Chap. 48:50

Motor Vehicles and Road Traffic

[Subsidiary]

Motor Vehicles and Road Traffic Regulations

(Regulation 13).

FORM 3

LICENCE FOR MOTOR VEHICLE

Motor Vehicles and Road Traffic Act, Ch. 48:50

FRONT

GOVERNMENT OF TRINIDAD AND TOBAGO

Licence No.

Reg. No.

Amount paid \$

Weight kilograms

No. of passengers

20.....*

Year*

BACK

Name of owner:

.....

Address:

.....

.....

.....

LAWS OF TRINIDAD AND TOBAGO

Motor Vehicles and Road Traffic

Chap. 48:50

191

Motor Vehicles and Road Traffic Regulations

[Subsidiary]

FORM 4

(Regulation 18).

MOTOR VEHICLES AND ROAD TRAFFIC REGULATIONS

APPLICATION FOR DRIVING PERMIT(S)/
ENDORSEMENT(S)

N.B.—It is an offence under the Act to give any particulars which are false or in any material respect misleading and you will be liable to prosecution if you do so. Answers *must* be typed or written in ink in block letters.

1. Type of permit(s)/endorsement(s) applied for—

(i) Transaction

First Issue Renewal Duplicate Provisional Endorsement

(ii) Classification

Motorcycle Light Motor Vehicle Heavy Motor Vehicle
 Extra Heavy Motor Vehicle Omnibus Tractor Wheel/Track
 Other

(iii) Use

Hiring Car/Taxi Commercial Private

2. Full name of applicant

Surname First Name Middle Name Maiden Name (if any)

3. Sex <input type="checkbox"/> Male <input type="checkbox"/> Female		4. Place of Birth	5. Date of Birth Day Month Year			
6. Nationality	7. Residential Address in Trinidad and Tobago		8. Postal Address if Different from (7)			
9. (i) Are you the holder of a driving permit issued in Trinidad and Tobago? <input type="checkbox"/> Yes <input type="checkbox"/> No			10. Give below particulars of any driving permits/licences held elsewhere than in Trinidad and and Tobago			
(ii) Have you previously been the holder of a Driving Permit issued in Trinidad and Tobago? <input type="checkbox"/> Yes <input type="checkbox"/> No						
(iii) If “yes” to (i) or (ii) state number and date of Issue below Number Date Month Year.....						
(iv) Class of vehicle authorised to drive						
			(a) Country	1	2	3
			(b) District			
			(c) Number			
			(d) Date issued			
			(e) Expiry Date			
11. Give particulars of any endorsement(s) on any driving permit/licence which you held or now hold.....						

LAWS OF TRINIDAD AND TOBAGO

192

Chap. 48:50 Motor Vehicles and Road Traffic

[Subsidiary]

Motor Vehicles and Road Traffic Regulations

12. Have you at any time been disqualified from obtaining a driving permit?
[] Yes [] No. If "yes" give particulars

13. Are your physique, hearing and bodily and mental fitness such as to qualify you for the issue of a driving permit?
[] Yes [] No

14.

Date Signature of Applicant

15.

DECLARATION IN RESPECT OF APPLICATION FOR DUPLICATE DRIVER'S PERMIT, TAXI DRIVER'S LICENCE/BADGE, MOTOR VEHICLE LICENCE, CONDUCTOR'S PERMIT

I, of in the Republic of Trinidad and Tobago do solemnly and sincerely declare as follows:

- 1. I am the holder of... No. which was issued/renewed for the year 20
2. The said ... No. was lost or stolen, on or about the ... day of ..., 20 ..., and although I have made a diligent search for the said ... I have been unable to find same.
3. The said ... No. was destroyed on or about the ... day of ..., 20 ...

And I make this declaration conscientiously believing the same to be true and according to the Statutory Declarations Act Ch. 7:04 and I am aware that if there is any statement in this declaration which is false in fact, which I know or believe to be false or do not believe to be true I am liable to fine and imprisonment.

Declared at this day of 20

Before me.

Commissioner of Affidavits

16. For Official Use

INSTRUCTIONS TO APPLICANTS

1. All applicants must complete questions 1–14.
2. Applicants applying for a “DUPLICATE” Permit must complete questions 1–15.
3. Tick boxes where applicable.
4. Question 1
 - (i) (a) “First Issue”—application for the first time for a permit for a particular class of vehicle.
 - (b) “Provisional”—application for a permit to learn to drive a vehicle of a particular class. Such permit is valid for one year only.
 - (ii) (a) “Motor Vehicle/Light”—includes any motor vehicle (e.g., motor car, station wagon, pick-up van, etc.) whose tare weight does not exceed 2,270 kilogrammes or whose m.g. does not exceed 2,950 kilogrammes.
 - (b) “Motor Vehicle/Heavy”—includes any motor vehicle whose m.g.w. exceeds 2,950 kilogrammes but does not exceed 15,240 kilogrammes.
 - (c) “Motor Vehicle/Extra Heavy”—includes any motor vehicle whose m.g.w. exceeds 15,240 kilogrammes.
 - (d) “Other”—includes application for a permit for a vehicle not listed at 1(ii) e.g., road roller, cranes, etc.
 - (iii) (a) “Private use”— includes use of a rented vehicle or use of any other vehicle for non-commercial purposes.
 - (b) “Commercial use”— means use of a vehicle primarily for industrial or trade purposes.

LAWS OF TRINIDAD AND TOBAGO

194

Chap. 48:50

Motor Vehicles and Road Traffic

[Subsidiary]

Motor Vehicles and Road Traffic Regulations

(Regulation 19).

FORM 5A

(Front)

<i>Photograph</i>			
	REPUBLIC OF TRINIDAD AND TOBAGO DRIVER'S PERMIT		
	Name and Address		
	Issue Date	Expiry Date	TR
	Birth Date	Sex	Class
Permit Number		Date of Payment	
<i>Signature of Holder</i>		<i>Signature of Licensing Officer</i>	

(Back)

Reminder Notice

This permit is valid for three years only from the date of First Issue or Anniversary Date of Renewal.

Restriction

Nil

Class

- (1) Motorcycles
- (2) Wheel tractors
- (3) Light motor vehicles
- (4) Heavy motor vehicles
- (5) Extra heavy motor vehicles
- (6) Omnibuses
- (7) Others

Transaction Code

- A.—First Issue
- B.—Renewal
- C.—Duplicate
- D.—Endorsement.

LAWS OF TRINIDAD AND TOBAGO

Motor Vehicles and Road Traffic

Chap. 48:50

195

Motor Vehicles and Road Traffic Regulations

[Subsidiary]

(Back)

Reminder Notice

This permit is valid for three years only from the date of First Issue or Anniversary Date of Renewal.

Restriction

Holder must wear corrective lenses Yes No
 Valid to drive automatic transmission only Yes No

Class

- (1) Motorcycles
- (2) Wheel tractors
- (3) Light motor vehicles
- (4) Heavy motor vehicles
- (5) Extra heavy motor vehicles
- (6) Omnibuses
- (7) Others

Transaction Code

- A.—First Issue
- B.—Renewal
- C.—Duplicate
- D.—Endorsement.

(Back)

Reminder Notice

This permit is valid for one year only from the date of First Issue or Anniversary Date of Renewal.

Restriction

Holder must wear corrective lenses Yes No
 Valid to drive automatic transmission only Yes No

Class

- (1) Motorcycles
- (2) Wheel tractors
- (3) Light motor vehicles
- (4) Heavy motor vehicles
- (5) Extra heavy motor vehicles
- (6) Omnibuses
- (7) Others

Transaction Code

- A.—First Issue
- B.—Renewal
- C.—Duplicate
- D.—Endorsement.

(Back)

Reminder Notice

This permit is valid for one year only from the date of First Issue or Anniversary Date of Renewal.

Restriction

Invalid or disabled driver valid while driving private motor car Registration No. only.

Class

- (1) Motorcycles
- (2) Wheel tractors
- (3) Light motor vehicles
- (4) Heavy motor vehicles
- (5) Extra heavy motor vehicles
- (6) Omnibuses
- (7) Others

Transaction Code

- A.—First Issue
- B.—Renewal
- C.—Duplicate
- D.—Endorsement.

LAWS OF TRINIDAD AND TOBAGO

196

Chap. 48:50

Motor Vehicles and Road Traffic

[Subsidiary]

Motor Vehicles and Road Traffic Regulations

(Regulation 19).

FORM 5B

(Front)

<i>Photograph</i>	 REPUBLIC OF TRINIDAD AND TOBAGO PROVISIONAL PERMIT			
	Name and Address			
	Issue Date		Expiry Date	
	Birth Date	Sex	Class	TR
	Permit Number		Date of Payment	
<i>Signature of Holder</i>		<i>Signature of Licensing Officer</i>		

(Back)

Reminder Notice

This permit is valid for one year only from the date of First Issue.

Restriction

A learner shall drive on such roads between the hours and days stipulated by the Commissioner of Transport.

Class

- (1) Motorcycles
- (2) Wheel tractors
- (3) Light motor vehicles
- (4) Heavy motor vehicles
- (5) Extra heavy motor vehicles
- (6) Omnibuses
- (7) Others

Transaction Code

- A.—First Issue
- B.—Renewal
- C.—Duplicate
- D.—Endorsement.

LAWS OF TRINIDAD AND TOBAGO

Motor Vehicles and Road Traffic

Chap. 48:50

197

Motor Vehicles and Road Traffic Regulations

[Subsidiary]

FORM 6

[Regulation 21(2)].

PARTICULARS TO BE GIVEN BY APPLICANT FOR CONDUCTOR'S PERMIT

Motor Vehicles and Road Traffic Act, Ch. 48:50

1. Full Name of Applicant	
2. Postal Address of Residence of Applicant ...	
3. State Date of Birth of Applicant	
4. Are you the holder of a Conductor's Permit, or have you at any time previously been the holder of a Conductor's Permit, if so, state number and date of issue	
5. State particulars of any endorsement on any Conductor's or Driver's Permit which you hold or have previously held	
6. Have you at any time been disqualified from obtaining a Conductor's or Driver's Permit. If so, give particulars as to the Court by whom, the date on which and the period for which the disqualification was imposed	

Signature of Applicant

Date of Application

LAWS OF TRINIDAD AND TOBAGO

198

Chap. 48:50

Motor Vehicles and Road Traffic

[Subsidiary]

Motor Vehicles and Road Traffic Regulations

(Regulation 27).

FORM 7

MOTOR VEHICLES INSPECTOR'S CERTIFICATE

Motor Vehicles and Road Traffic Act, Ch. 48:50

No.

I hereby certify that:

(1) I have personally made a thorough examination of, and have driven and tested the—

- Hiring Car or Taxi No. H. ... Lorry No. T ...
Omnibus No. H. ... Van No. T ...
Light Omnibus No. H. ... Trailer No. T ...
Freight Passenger Vehicle No. H. ... Goods Vehicle using fuel other than Petrol No. T ...
Petrol No. H. ...

Owned by

of ... which is described below—

- (a) Chassis manufactured by ...
(b) Model ... W.B for G-V or M.O ...
(c) Year manufactured ...
(d) Engine No. ... No. of Cylinders ...
(e) Make ... Fuel ...
(f) Factory number of chassis ...
(g) Maker's maximum gross weight in kilogrammes when new ...
(h) Type of body ...
(i) Tare in kilogrammes ...

and found the condition of its several parts to be—

- Chassis ...
Engine ...
Body ...
Tyres ...
Brakes ...
Mechanism ...

and have allowed a—

- Longitudinal Overhang of ...
Lateral Overhang of ... R Wheels Dual or Single Tyres ...

(2) The said vehicle ... conforms to the Regulations for the time being in force under the Motor Vehicles and Road Traffic Act Ch. 48:50 and is in good and proper condition to carry ... passengers. Be licensed for a Maximum Gross Weight of ... kilogrammes. Licence duty to be paid \$...

LAWS OF TRINIDAD AND TOBAGO

Motor Vehicles and Road Traffic

Chap. 48:50

199

Motor Vehicles and Road Traffic Regulations

[Subsidiary]

- (3) That not more than persons may sit on the left/right of the driver.
- (4) Inspection Receipt bearing No. dated 20, for the Inspection Fee has been produced and seen by me.
- (5) And that the said may be duly licensed for the year

.....
Motor Vehicles Inspector

Date of certificate, 20

[Regulation 27(3)].

FORM 8

REGISTER TO BE KEPT BY MOTOR VEHICLES INSPECTORS

1	2	3	4	5	6	7	8	9	10	11
Number of Certificate issued	Date of first inspection	Date of Certificate issued	Registered Number of Vehicle	Name of Owner	Address of Owner	Type of Vehicle	Number of Passengers to be carried	Tare in kilogrammes	M.G.W. in kilogrammes	Remarks

LAWS OF TRINIDAD AND TOBAGO

Motor Vehicles and Road Traffic

Chap. 48:50

201

Motor Vehicles and Road Traffic Regulations

[Subsidiary]

FORM 9

(Section 34 of Act).

FORM OF APPLICATION FOR DEALER'S GENERAL LICENCE

Motor Vehicles and Road Traffic Act, Ch. 48:50

- 1. Full name of Applicant
2. Place of business
3. Nature of business (Dealer, manufacturer or repairer)
4. Number of general identification marks required
5. Insured with
6. Terms of Policy
7. Number of Policy
8. Date Policy expires

Signature of Owner. Date

N.B.—Vide ss. 34–40 of the Act and regulation 11.

FORM 10

(Section 35 of Act).

Licence No.

FORM OF DEALER'S GENERAL LICENCE

Motor Vehicles and Road Traffic Act, Ch. 48:50

- 1. A dealer's general licence is hereby granted to ... of ... under section 35 of the Act as a dealer/manufacturer/repairer of motor vehicles, subject to the provisions of the Act and Regulations.
2. The following general identification marks are assigned under this licence
3. This licence expires on 31st December

Date Licensing Authority.

N.B.—Motor vehicles used under the authority of this licence must be the property of the licence holder and may only be used for the purposes defined in section 35 of the Act and subject to the provisions of regulation 11.

LAWS OF TRINIDAD AND TOBAGO

202

Chap. 48:50

Motor Vehicles and Road Traffic

[Subsidiary]

Motor Vehicles and Road Traffic Regulations

(Section 36 of Act).

FORM 11

FORM OF REGISTER OF DEALERS' GENERAL LICENCES TO BE KEPT BY THE TRANSPORT OFFICER

Motor Vehicles and Road Traffic Act, Ch. 48:50

No. of licence issued and date of issue	Name of licensee and place of business	Whether licensed as dealer, manufacturer or repairer	Insurance Company, terms of policy. No. of policy	Date of expiration of policy	Numbers of identification marks assigned

LAWS OF TRINIDAD AND TOBAGO

Motor Vehicles and Road Traffic

Chap. 48:50

203

Motor Vehicles and Road Traffic Regulations

[Subsidiary]

FORM 12

(Regulation 26).

MOTOR VEHICLES AND ROAD TRAFFIC REGULATIONS

MEDICAL TEST FOR DRIVING PERMIT

FORM OF MEDICAL CERTIFICATE FOR AN APPLICANT FOR A LICENCE TO DRIVE MOTOR VEHICLES

In the case of suspected medical unfitness it is important that the Licensing Authority be satisfied on the following points before the grant of a driving permit:

Reply to be given in this column

- 1. Is the applicant, to the best of your judgment, subject to epilepsy, vertigo or any mental ailment likely to affect his efficiency?
2. Does the applicant suffer from any heart or lung disorder which might interfere with the performance of his duties as a driver?
3. What is the Blood pressure reading? (Both systolic and diastolic readings should be given).
4. (a) Is there any defect of vision? (See Note I). (b) If a defect of vision is revealed on examination, give acuity of vision by Shellen's Test. (c) Do you consider that the applicant should wear glasses when driving? (d) Is there any defect of hearing?
5. Has the applicant any deformity or loss of members? If so, would it interfere with the efficient performance of his duties as a driver? (See Note II).
6. Is he sufficiently active for the performance of his duties?
7. Does he show any evidence of being addicted to the excessive use of alcohol, tobacco or drugs?
8. Is he, in your opinion, generally fit as regards— (a) bodily health and (b) temperament for the duties of a motor car driver?

LAWS OF TRINIDAD AND TOBAGO

204

Chap. 48:50

Motor Vehicles and Road Traffic

[Subsidiary]

Motor Vehicles and Road Traffic Regulations

Notes: I—Special attention should be directed to distant vision.

II—Special attention is directed to the condition of the arms, hands, legs and joints of the upper and lower extremities.

The applicant is responsible for the payment of any fee in connection with the examination and is NOT a charge on Public funds.

The Certificate is for the confidential use of the Licensing Authority and its contents are not divulged to anybody other than the applicant.

It is an offence under section 94 of the Motor Vehicles and Road Traffic Act, Ch. 48:50, for any person to “make any statement which to his knowledge is false, or in any material respect misleading”, and the penalty on conviction is \$240 or six months hard labour or to both such fine and imprisonment.

It is suggested the applicant might be so warned before the examination is made.

TO THE LICENSING AUTHORITY FOR TRINIDAD AND TOBAGO

I certify I have this day examined the applicant

The answers to the foregoing questions are correct to the best of my knowledge and belief and I consider him fit/unfit to act as driver of motor cars.

Signature, etc. of

Qualified and Registered

Medical Practitioner

Address

Date

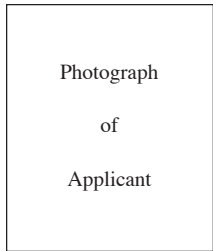

SECOND SCHEDULE

(Regulation 7).

Alternative Diagram No. 1



Alternative Diagram No. 2



The alternative diagrams above are specimen plates drawn approximately to a scale of one-third. The actual size of the plate will, however, differ according to the number of letters and figures required.

LAWS OF TRINIDAD AND TOBAGO

206

Chap. 48:50

Motor Vehicles and Road Traffic

[Subsidiary]

Motor Vehicles and Road Traffic Regulations

(Regulation 92).

***THIRD SCHEDULE**

PARKING PLACES

PORT-OF-SPAIN

1. *DeLuxe Theatre and Victoria Institute*.—Keate Street, North side, facing East between Frederick Street and Chancery Lane.
2. *Vistarama Theatre*—
 - (i) St. Vincent Street, facing South, between Park and Gordon Streets;
 - (ii) Oxford Street, South side facing West, between St. Vincent and Abercromby Streets and between Abercromby and Pembroke Streets; and North side, facing West, between St. Vincent and Edward Streets.
3. *Globe Theatre*—
 - (i) Park Street, North side, facing West between St. Vincent and Edward Streets;
 - (ii) Edward Street, facing North, between Park Street and Tragarete Road;
 - (iii) Edward Street, facing North, between Park and Duke Streets.
4. *Astor Theatre*—French Street, between Ariapita Avenue and the Eastern entrance to the Theatre.
5. *Olympic Theatre*—Pelham Street, between Erthig Road and Jerningham Avenue.
6. *Roxy Theatre*—Damian Street, South of the Road Sign on the road surface.
7. *Royal Theatre*—Charlotte Street, between Oxford Street and Observatory Street at a point seventy metres North of Park Street.
8. *Clydesdale Club*—Stanmore Avenue, East side facing South, between Queen's Park West and Albion Street.

*This Schedule was amended by the following GNs: 148/1958, 32/1964, 73/1966, 206/1979, 207/1979, 208/1979 and 211/1979.

LAWS OF TRINIDAD AND TOBAGO

9. *Cosmos Club*—New Street, North side, facing East, between St. Vincent and Edward Streets.

10. *Portuguese Association*—Richmond Street, facing South between Duke and Park Streets.

11. *Portuguese Club, Shamrock Club and the Overseas Forces Club*—Queen’s Park East, West side, facing North, between Park Avenue and Belmont Circular Road.

12. *Casuals Club*—Queen’s Park West, North side facing East, between Picton Street and a point three metres West of the Club entrance.

13. *Union Club*—Independence Square South, both sides; facing West, between Chacon and Abercromby Streets.

14. *Queen’s Park Cricket Club*—Elizabeth Street, West side, facing North, between St. Clair Avenue and Tragarete Road.

15. *Queen’s Park Hotel*—

- (i) Queen’s Park West, North side, facing East, between Cipriani Boulevard and a point three metres West of the central entrance to the Hotel;
- (ii) Victoria Avenue, East side, facing South, between Tragarete Road and Queen’s Park West.

16. *Botanic Gardens*—Circular Road, South side, facing West, between Lady Chancellor Road and a point eight metres West of the main Entrance to President’s House.

17. *Town Hall and Public Library*—Knox Street, South side, facing East between Frederick and Pembroke Streets.

18. *Trinidad Dairies*—Phillips Street, West side, facing North, between Tragarete Road and Kew Place.

19. *Masonic Temple*—Alexandra Street, East side, facing North, between Tragarete Road and Sweet Briar Road.

20. *St. Ann’s Hall*—Oxford Street, South side facing West, from Charlotte Street to Observatory Street.

LAWS OF TRINIDAD AND TOBAGO

208

Chap. 48:50

Motor Vehicles and Road Traffic

[Subsidiary]

Motor Vehicles and Road Traffic Regulations

PARKING PLACES—*Continued*

21. *Independence Square Tennis Club*—George Street, facing North from Independence Square South to South Quay.

22. *India Club*—Cipriani Boulevard between Queen's Park West and Tranquillity Street, East side facing South.

23. *Hankow Restaurant*—Charlotte Street between Queen Street and Independence Square North.

LAWS OF TRINIDAD AND TOBAGO

Motor Vehicles and Road Traffic

Chap. 48:50

209

Notice of Exemption from Requirement to hold a Driver's Permit issued in a Foreign Country

[Subsidiary]

FOURTH SCHEDULE

(Regulation 111).

REPUBLIC OF TRINIDAD AND TOBAGO

FORM OF APPLICATION FOR TAXI DRIVER'S LICENCE

- 1. Full name of applicant (Surname first, in block letters)
2. Postal address of residence of applicant
3. State number of Driver's Permit (Motor Vehicles and Road Traffic Act) and date of issue
4. State date and place of birth
Signature of Applicant
Date of Application

FIFTH SCHEDULE

(Regulation 111).

REPUBLIC OF TRINIDAD AND TOBAGO

TAXI DRIVER'S LICENCE

Photograph of Holder } Licence No. To Drive a Taxi Driver's Permit No.

..... of, is hereby licensed to drive a taxi.

Dated this day of, 20

Signature of holder

..... Licensing Authority

FEE \$10.00

SIXTH SCHEDULE

**RESPONSIBILITIES OF A VEHICLE TESTING STATION
PROPRIETOR/EXAMINER**

1. This document outlines the responsibilities of the Proprietor of premises at which road safety inspection checks are to be performed as well as those of the Examiner, the person who actually performs the inspection checks.

2. For the purposes of this document the following terms would have the meaning defined:

“Act” means the Motor Vehicles and Road Traffic Act (Ch. 48:50);

“Authority” means the Licensing Authority;

“Examiner” means a person certified by the Authority as possessing the standard of qualifications, skills and experience to perform the inspection checks necessary for determining the road worthiness of private motor vehicles and motorcycles. It also means that the person has also attended the Authority’s training/orientation programme and has met the standards determined for certification. A Proprietor may be certified as a Tester if he possesses the necessary combination of qualifications, experience and training;

“Proprietor” means individual partnership or company whose premises has met the standards determined by the Authority upon application for the performance of road safety inspection checks on private cars and motorcycles;

“Vehicle Testing Station” refers to premises approved by the Authority in accordance with section 26 of the Act.

GUIDELINES FOR PROPRIETORS

3. The Proprietor shall be issued with a Designation (Appendix I) duly signed and dated by the Authority authorising and identifying the premises to be used as a Vehicle Testing Station.

4. (1) The Proprietor shall—

- (a) submit the name(s) of any of his employees possessing appropriate technical qualifications, skills and experience as an auto mechanic for assessment by the Authority for selection. Such persons are to attend an approved training/orientation course developed for persons wishing to perform the duties of an examiner. Persons not possessing the full qualifications,

but who have submitted evidence of a suitable working experience of at least five (5) years as an auto mechanic shall be subjected to an examination prepared by the Authority for determining their suitability for certification to perform the duties as examiners;

- (b) ***(Deleted by LN 34/2003);***
- (c) notify the Authority of any change in their Testing Staff, clearly stating the reason(s) for such change;
- (d) ensure that—
 - (i) suitable accommodation for customers and staff is provided, kept in a tidy condition and a good state of repair (*See Appendix II for details of accommodation*);
 - (ii) customers are able to witness the inspection check from a safe and comfortable position;
- (e) have available in good working order all equipment and facilities as listed in Appendix II;
- (f) ensure that an adequate supply of the various documents to be used in the inspection process is always available. Documents shall include such other form(s) that the Authority may prescribe from time to time. Requisitions for these documents shall be made on the form provided at Appendix XI;
- (g) ensure that all stamps, seals and documents are kept in a safe place and under the control of the Proprietor;
- (h) ensure that a monthly return is made to the Authority on the prescribed form of all vehicles that have undergone an inspection check at the Testing Station within seven (7) days from the end of each month;
- (i) retain a copy of Monthly Returns, Inspection Checklists, and Certificate of Inspection for at least twenty-four (24) months so that Duplicate Inspection Certificates/Stickers can be prepared as needed;
- (j) deliver to the Authority all official documents on request by the Authority on suspension/cessation of Vehicle Testing Station operations;
- (k) ensure that a notice indicating opening and closing hours should be on display in a conspicuous place outside the premises;
- (l) display in a conspicuous place on his premises the prescribed “Vehicle Testing Station” sign clearly showing the V.T.S. No. assigned;
- (m) display in the waiting room of the premises in a conspicuous manner the certificate of authorisation for the operations of the Vehicle Testing Station as in Appendix III and the certification of the Tester(s) as in Appendix IV;

- (n) display in a conspicuous place a notice that informs customers of the right to lodge complaint(s) on the appropriate form to the Authority about any grievance in relation to the inspection proceedings or otherwise;
- (o) make the premises and records available for examination by officers authorised by the Authority;
- (p) inform the Authority of any changes affecting the ownership, control, layout and operations of the Testing Station;
- (q) ensure that the Testing Station complies with any guidelines set out by the Town and Country Planning Division, Local Health Authority, Fire Services and other Regulatory Agencies;
- (r) ensure that the premises are covered by adequate liability insurance for any injury, loss or damage that may occur on the premises and for which it is liable;
- (s) ensure that the day-to-day operations of the Testing Station are organised so as to avoid undue congestion on the premises;
- (t) ensure that vehicles registered in the name of the Proprietor are not inspected at the Testing Station belonging to the Proprietor;
- (u) allow facilities to be used by authorised personnel from the Authority to carry out tests on vehicles of applicants who have appealed decisions made at their respective Testing Stations.

(2) A person who fails to submit a return in accordance with subparagraph (1)(h) is required to pay a fine of one thousand dollars.

GUIDELINES FOR EXAMINERS

5. Having completed the approved training/orientation course issued by the Authority and on application of the examiner (Appendix V) a certificate shall be issued duly signed and dated by the Authority authorising the examiner to perform inspection checks on privately registered motor vehicles (not exceeding 2,270 kg.) and motorcycles.

6. The examiner shall ensure that—

- (a) tests are carried out and completed as far as possible without interruption;
- (b) inspections of vehicles are carried out in accordance with the Act and these Guidelines as well as any instructions or supplementary directives that may be issued from time to time by the Authority;
- (c) that all documents are signed and dated accurately;

- (d) when the inspection check has been completed but the vehicle has failed to meet the statutory requirements, the original copy of the Inspection Checklist, signed and dated by the examiner and detailing all defects discovered, must be issued to the person who brought in the vehicle;
- (e) when the inspection check is completed and the vehicle is found to meet statutory requirements, a certificate of inspection (Appendix VII) signed and dated by the Tester is then issued in the name of the registered owner of the vehicle;
- (f) an official sticker (Appendix VIII) supplied by the Authority is then affixed to the lower left-hand corner of the front windshield of the vehicle. In the case of a motorcycle the sticker should be affixed to a conspicuous place at the front;
- (g) where it is the opinion of the Examiner that there has been tampering with the chassis/engine number an immediate report should be lodged with the nearest office of the Authority. The make, model, number of the vehicle, together with the name and address of the registered owner should be noted and forwarded. The examiner has no power to impound the vehicle;
- (h) while on duty the examiner is required to wear an official Examiner's Identification showing that he/she is a certified Examiner working at the Testing Station (Appendix IX).

GENERAL

7. The various fees and charges in respect of the Testing Station operations may be reviewed annually, but for the time being consist of the following:

Fees—

- (a) testing stations shall be subjected to the payment of a Registration Fee (of \$1,000.00) payable to the Authority;
- (b) an annual renewal fee of (\$500.00) shall be paid to the Authority;
- (c) an Examiner is liable to a certification fee of \$300.00 payable to the Authority for a period to two (2) years. Certification would be renewable at the same cost from the date of issue on a biannual basis;
- (d) (i) Proprietors are to purchase the inspection documents from the Authority;
- (ii) the inspection fee payable for the time being shall be made up as follows:

Inspection	\$ 100.00
Vat	\$ 15.00
Reimbursement for inspection documents	\$ 50.00

Authorised Testing Stations must be VAT registered—

- (e) a vehicle that has failed the road safety inspection check is entitled to a free inspection if it is brought back to the same Testing Station at any time for inspection within six (6) weeks of the date of the first inspection;
- (f) a vehicle that is inspected after six (6) weeks of the date of the first inspection would be subjected to a complete inspection for which an additional inspection fee of one hundred dollars (\$100.00) would be paid by the vehicle's owner.

Registers—

- (g) the Authority shall keep a register of all premises authorised to function as Testing Stations;
- (h) the Authority shall keep a register of all persons certified as Examiners and the respective Testing Stations at which they are to function.

FORMS

8. The official forms which are used in connection with the Vehicle Testing Programme are listed below together with notes on their use—

- (a) Designation Instrument (Appendix I);
- (b) Accommodation, Equipment and Inspection Pit (Appendix II);
- (c) Testing Station Authorisation (Appendix III);
- (d) Examiner Certificate (Appendix IV);
- (e) Application Form Certification for a Vehicle Examiner (Appendix V);
- (f) Inspector Checklist (Appendix VI);
- (g) Inspector/Test Certificate (Appendix VII);
- (h) Inspector Sticker (Appendix VIII);
- (i) Examiner's Identification (Appendix IX);
- (j) Application for premises to be used as a Vehicle Testing Station compound (Appendix X);

Any false statement may put the application or any authorisation resulting from it, at risk. The form must be signed by the Proprietor, or by a partner in the case of a partnership. In the case of a company, it should be signed by a director or any other authorised by the director.

- (k) Application for inspection documents (Appendix XI);
- (l) Monthly returns (Appendix XII);

An authorised Proprietor is required to record in this Return particulars of all tests carried out at the Testing Station. The record must indicate whether the vehicle satisfies the

requirement of an inspector, or otherwise. The register must be kept at the Testing Station for at least twenty-four (24) months and a copy of the register must be forwarded to the Licensing Authority within seven (7) days after the end of the month to which it refers. It must be accompanied with the duplicate copies of certificates of inspection for the period.

(m) **Complaint/Grievance Notice (Appendix XIII).**

*This form is to be used by anyone who wishes to record a complaint or grievance, and must be sent to the Licensing Authority within seven (7) days of the incident. The forms must be held at the Testing Station and a poster (**Appendix XIV**) detailing the appeal procedure must be displayed where it can be read by members of the public.*

Certificates of Inspection

9. (a) Certificates of Inspection Book(s) shall be issued only on receipt of a requisition together with the appropriate fee.

(b) A certificate of inspection must be completed in triplicate on the same day of the test. The certificate must always be signed by the person who carried out the test **and embossed with the Testing Station Seal**. The duplicate copy must accompany the Monthly Return.

(c) The month of issue and expiry must always be stated first followed by the day and year. No space must be left in which figures can be inserted. The last two figures of the year must also be entered in words to prevent alteration.

Example: Date of issue June 24, 1991 (ninety-one)
Date of expiry June 23, 1992 (ninety-two).

(d) **The name and number of the issuing Testing Station must be embossed** in the space marked "Signature of Inspector/Tester". Rubber stamps are not acceptable.

(e) The "date of issue" will always be the date on which the certificate is completed. It is effective for twenty-four (24) months from the date of issue. However, if there is a current certificate of inspection for the vehicle, the date of expiry on the new certificate shall be twenty-four months from the date of expiry shown on the current certificate. Examiners must always enquire of the owner for a current certificate and if applicable, its serial number must be **recorded on the new certificate in the space provided**. The certificate shall not be altered if the current certificate is produced at a later date. This advice should also be given if the "date of expiry" entered by the tester is disputed.

LAWS OF TRINIDAD AND TOBAGO

216

Chap. 48:50

Motor Vehicles and Road Traffic

[Subsidiary]

Motor Vehicles and Road Traffic Regulations

**Example: Date of issue of previous certificate 12th May, 1991;
Date of expiry of previous certificate 11th May, 1993;
Date of issue of new certificate 28th May, 1993;
Date of expiry to be entered on new certificate
10th May 1995.**

(f) An inspection check cannot be performed more than one (1) month before the expiry date of the current certificate of inspection.

10. Official documents (Inspection Checklist, Certificates of Inspection and Monthly Return, etc.) must be completed in indelible ink or ballpoint pen and a clear carbon copy must be taken. Entries must be written clearly and firmly to ensure that any subsequent attempt to alter them will be obvious.

APPENDIX I

REPUBLIC OF TRINIDAD AND TOBAGO

DESIGNATION AS AUTHORISED PREMISES
AS A VEHICLE TESTING STATION

The following premises, namely: _____

as owned and operated by _____

_____, authorised Proprietor(s) is hereby designated as a Vehicle Testing Station for the purposes of the inspection of motor vehicles under the provisions of the Motor Vehicles and Road Traffic Act, (Ch. 48:50).

Dated thisday of, 20.....

.....
Transport Commissioner

APPENDIX II

SUITABLE ACCOMMODATION, EQUIPMENT AND INSPECTION PIT

1. ACCOMMODATION

- a. Staff Office
- b. Public Waiting Room
- c. Brake Testing Area
- d. Parking Facilities
- e. Entry and Exit Point

2. EQUIPMENT

- a. Hydraulic Jack (3-ton and 6 tons)
- b. Head Lamp Spot and Alignment Tester
- c. *Brake Efficiency Tester
- d. Tyre Tread Depth Tester
- e. Cro-Bars
- f. *Emission Tester
- g. *Smoke Meter
- h. 1/4 lb Engineer's Hammer

3. INSPECTION PIT

- a. Width 2' 7"
- b. Length 25' to 33'
- c. Depth 5' 6"
- d. Extension Light

and/or

4. RAMP

and/or

5. HOST

SPECIAL NOTE * Within one (1) year the intention is for all Testing Stations to be equipped with Brake Testing and Emission Control Machines. Proprietors are to note that this can be a precondition for the renewal of the Licence to operate a Testing Station.

APPENDIX III

TRANSPORT DIVISION
TESTING STATION AUTHORISATION

I certify that of this day of, 20.....

.....

has been approved as a **Vehicle Testing Station**. You are duly authorised to perform roadworthy checks on all Motorcycles and

Private Cars **not exceeding a Tare Weight of 2,270 kg.**

Valid until the day of, 20.....

.....

Date

.....

Transport Commissioner

APPENDIX IV

TRANSPORT DIVISION

VEHICLE EXAMINER'S CERTIFICATE

This is to certify that of this day of, 20.....

Mr./Ms.

has been duly certified as an authorised Examiner of all Motorcycles and Private Cars **not exceeding a Tare Weight of 2,270 kg.**

Testing Station #.....

Valid until the day of, 20.....

.....
Date
.....
Transport Commissioner

LAWS OF TRINIDAD AND TOBAGO

220

Chap. 48:50

Motor Vehicles and Road Traffic

[Subsidiary]

Motor Vehicles and Road Traffic Regulations

APPENDIX V

MINISTRY OF WORKS AND TRANSPORT

APPLICATION FOR CERTIFICATION AS A VEHICLE EXAMINER

NAME (Block Letters)

ADDRESS (Block Letters)

NAME OF TESTING STATION (Block Letters)
(if Applicable)

VEHICLE TESTING STATION No.:

PASSPORT/ID No.

DRIVER'S PERMIT No.

.....
Date

.....
Signature

For Official Use

LAWS OF TRINIDAD AND TOBAGO

Motor Vehicles and Road Traffic

Chap. 48:50

221

Motor Vehicles and Road Traffic Regulations

[Subsidiary]

APPENDIX VI

TRANSPORT DIVISION

For Official Use

MOTOR VEHICLE INSPECTION CHECKLIST

No.

Name/Address of Inspector/Testing Site Testing Centre No.

Date Inspection No.

Vehicle Registration No. Registered Owner

1. Required Documentation:		Good	Defective	4. Electrical:		Good	Defective
(a) Inspection Receipt	<input type="checkbox"/>	<input type="checkbox"/>	<input type="checkbox"/>	(a) Head lamps including focus	<input type="checkbox"/>	<input type="checkbox"/>	<input type="checkbox"/>
(b) Certificate of Ownership	<input type="checkbox"/>	<input type="checkbox"/>	<input type="checkbox"/>	(b) Park lamps	<input type="checkbox"/>	<input type="checkbox"/>	<input type="checkbox"/>
(c) Vehicle/Trailer Insurance	<input type="checkbox"/>	<input type="checkbox"/>	<input type="checkbox"/>	(c) Tail Lamps	<input type="checkbox"/>	<input type="checkbox"/>	<input type="checkbox"/>
2. Identification of Vehicle/trailer				(d) Rear Registration Plate Light	<input type="checkbox"/>	<input type="checkbox"/>	<input type="checkbox"/>
Verify:	Good	Defective		(e) Indicators	<input type="checkbox"/>	<input type="checkbox"/>	<input type="checkbox"/>
(a) Vehicle painted according to law	<input type="checkbox"/>	<input type="checkbox"/>		(f) Horn (Note: It must be non-musical)	<input type="checkbox"/>	<input type="checkbox"/>	<input type="checkbox"/>
(b) VIN/Chassis No.				(g) Wipers	<input type="checkbox"/>	<input type="checkbox"/>	<input type="checkbox"/>
(c) Body number (if applicable)				(h) Passenger Stop Buzzer (Maxi-Taxi)	<input type="checkbox"/>	<input type="checkbox"/>	<input type="checkbox"/>
(d) Engine Number				(i) Taxi Sign Lamp (Maxi-Taxi)	<input type="checkbox"/>	<input type="checkbox"/>	<input type="checkbox"/>
(e) Weight				(j) Loose Wires, Switches, etc.	<input type="checkbox"/>	<input type="checkbox"/>	<input type="checkbox"/>
(f) Description of Vehicle:				5. Body/door/fenders/panels/glasses/seats			
(i) Colour				(a) Operation of:	Good	Defective	
(ii) Year manufactured				(i) Hinges, locks, winders, etc.	<input type="checkbox"/>	<input type="checkbox"/>	
(iii) Model				(ii) Doors, Bonnet, Trunk in fair condition	<input type="checkbox"/>	<input type="checkbox"/>	
(iv) Seating				(iii) Entrance/exit door (Maxi-Taxi)	<input type="checkbox"/>	<input type="checkbox"/>	
(v) Type				(iv) Emergency door (Maxi-Taxi)	<input type="checkbox"/>	<input type="checkbox"/>	
(vi) Horse Power				(b) Condition of Fender/Panels (i.e., not excessively corroded)	<input type="checkbox"/>	<input type="checkbox"/>	
(vii) Engine Size				(c) Seats secured	<input type="checkbox"/>	<input type="checkbox"/>	
3. Engine:				(d) Seat Belt	<input type="checkbox"/>	<input type="checkbox"/>	
(a) Oil and Fuel Leaks	<input type="checkbox"/>	<input type="checkbox"/>		(e) Seat Upholstered	<input type="checkbox"/>	<input type="checkbox"/>	
(b) Water/Coolant Leaks	<input type="checkbox"/>	<input type="checkbox"/>		(f) Glasses (Windscreens included)	<input type="checkbox"/>	<input type="checkbox"/>	
(c) Operation of cut-off switch (Diesel Trucks)	<input type="checkbox"/>	<input type="checkbox"/>		(g) Tint of Glasses	<input type="checkbox"/>	<input type="checkbox"/>	
(d) Starter Mechanism	<input type="checkbox"/>	<input type="checkbox"/>		(h) Outside mirror	<input type="checkbox"/>	<input type="checkbox"/>	
(e) Engine properly washed	<input type="checkbox"/>	<input type="checkbox"/>		(i) Length, Width and overhangs	<input type="checkbox"/>	<input type="checkbox"/>	
(f) Battery properly secured	<input type="checkbox"/>	<input type="checkbox"/>		(j) Bumpers secured	<input type="checkbox"/>	<input type="checkbox"/>	
(g) Tuned properly	<input type="checkbox"/>	<input type="checkbox"/>					
(h) Visible Vapour/Sparks, etc.	<input type="checkbox"/>	<input type="checkbox"/>					

LAWS OF TRINIDAD AND TOBAGO

222

Chap. 48:50

Motor Vehicles and Road Traffic

[Subsidiary]

Motor Vehicles and Road Traffic Regulations

APPENDIX VI—Continued

<p>6. Markings:</p> <table border="0"> <thead> <tr> <th></th> <th>Good</th> <th>Defective</th> </tr> </thead> <tbody> <tr> <td>(a) Letter (S) painted on all special Vehicles</td> <td><input type="checkbox"/></td> <td><input type="checkbox"/></td> </tr> <tr> <td>(b) M.G.W., Tare and Licence Weight clearly marked and are to Regulation's size and colour</td> <td><input type="checkbox"/></td> <td><input type="checkbox"/></td> </tr> <tr> <td>(c) "LEFT-HAND DRIVE" painted at the Rear of Left-Hand Drive Vehicles</td> <td><input type="checkbox"/></td> <td><input type="checkbox"/></td> </tr> <tr> <td>(d) Correct number of passengers' sign on all Taxis and Maxi-Taxis</td> <td><input type="checkbox"/></td> <td><input type="checkbox"/></td> </tr> <tr> <td>(e) Number Plates are of Regulation size and colour</td> <td><input type="checkbox"/></td> <td><input type="checkbox"/></td> </tr> </tbody> </table>		Good	Defective	(a) Letter (S) painted on all special Vehicles	<input type="checkbox"/>	<input type="checkbox"/>	(b) M.G.W., Tare and Licence Weight clearly marked and are to Regulation's size and colour	<input type="checkbox"/>	<input type="checkbox"/>	(c) "LEFT-HAND DRIVE" painted at the Rear of Left-Hand Drive Vehicles	<input type="checkbox"/>	<input type="checkbox"/>	(d) Correct number of passengers' sign on all Taxis and Maxi-Taxis	<input type="checkbox"/>	<input type="checkbox"/>	(e) Number Plates are of Regulation size and colour	<input type="checkbox"/>	<input type="checkbox"/>	<p>10. Under Carriage</p> <table border="0"> <thead> <tr> <th>Check for:</th> <th>Good</th> <th>Defective</th> </tr> </thead> <tbody> <tr> <td>(a) Washed under carriage</td> <td><input type="checkbox"/></td> <td><input type="checkbox"/></td> </tr> <tr> <td>(b) Exhaust System:</td> <td></td> <td></td> </tr> <tr> <td> (i) Noise</td> <td><input type="checkbox"/></td> <td><input type="checkbox"/></td> </tr> <tr> <td> (ii) Corrosion</td> <td><input type="checkbox"/></td> <td><input type="checkbox"/></td> </tr> <tr> <td> (iii) Length</td> <td><input type="checkbox"/></td> <td><input type="checkbox"/></td> </tr> <tr> <td>(c) Drive Shaft, Universal Joint and Centre Bearing</td> <td><input type="checkbox"/></td> <td><input type="checkbox"/></td> </tr> <tr> <td>(d) Front and Rear spring "U" Clamps Bolts</td> <td><input type="checkbox"/></td> <td><input type="checkbox"/></td> </tr> <tr> <td>(e) For Loose Body to Chassis Frame Bolts</td> <td><input type="checkbox"/></td> <td><input type="checkbox"/></td> </tr> </tbody> </table>	Check for:	Good	Defective	(a) Washed under carriage	<input type="checkbox"/>	<input type="checkbox"/>	(b) Exhaust System:			(i) Noise	<input type="checkbox"/>	<input type="checkbox"/>	(ii) Corrosion	<input type="checkbox"/>	<input type="checkbox"/>	(iii) Length	<input type="checkbox"/>	<input type="checkbox"/>	(c) Drive Shaft, Universal Joint and Centre Bearing	<input type="checkbox"/>	<input type="checkbox"/>	(d) Front and Rear spring "U" Clamps Bolts	<input type="checkbox"/>	<input type="checkbox"/>	(e) For Loose Body to Chassis Frame Bolts	<input type="checkbox"/>	<input type="checkbox"/>
	Good	Defective																																												
(a) Letter (S) painted on all special Vehicles	<input type="checkbox"/>	<input type="checkbox"/>																																												
(b) M.G.W., Tare and Licence Weight clearly marked and are to Regulation's size and colour	<input type="checkbox"/>	<input type="checkbox"/>																																												
(c) "LEFT-HAND DRIVE" painted at the Rear of Left-Hand Drive Vehicles	<input type="checkbox"/>	<input type="checkbox"/>																																												
(d) Correct number of passengers' sign on all Taxis and Maxi-Taxis	<input type="checkbox"/>	<input type="checkbox"/>																																												
(e) Number Plates are of Regulation size and colour	<input type="checkbox"/>	<input type="checkbox"/>																																												
Check for:	Good	Defective																																												
(a) Washed under carriage	<input type="checkbox"/>	<input type="checkbox"/>																																												
(b) Exhaust System:																																														
(i) Noise	<input type="checkbox"/>	<input type="checkbox"/>																																												
(ii) Corrosion	<input type="checkbox"/>	<input type="checkbox"/>																																												
(iii) Length	<input type="checkbox"/>	<input type="checkbox"/>																																												
(c) Drive Shaft, Universal Joint and Centre Bearing	<input type="checkbox"/>	<input type="checkbox"/>																																												
(d) Front and Rear spring "U" Clamps Bolts	<input type="checkbox"/>	<input type="checkbox"/>																																												
(e) For Loose Body to Chassis Frame Bolts	<input type="checkbox"/>	<input type="checkbox"/>																																												
<p>7. Body/chassis frame</p> <table border="0"> <thead> <tr> <th>Check for:</th> <th>Good</th> <th>Defective</th> </tr> </thead> <tbody> <tr> <td>(a) Severe body/chassis frame damage including corrosion</td> <td><input type="checkbox"/></td> <td><input type="checkbox"/></td> </tr> <tr> <td>(b) Cut and Joined bodies and chassis</td> <td><input type="checkbox"/></td> <td><input type="checkbox"/></td> </tr> </tbody> </table>	Check for:	Good	Defective	(a) Severe body/chassis frame damage including corrosion	<input type="checkbox"/>	<input type="checkbox"/>	(b) Cut and Joined bodies and chassis	<input type="checkbox"/>	<input type="checkbox"/>	<p>11. Brakes</p> <table border="0"> <thead> <tr> <th>Condition of:</th> <th>Good</th> <th>Defective</th> </tr> </thead> <tbody> <tr> <td>(a) Brake Shoe Lining</td> <td><input type="checkbox"/></td> <td><input type="checkbox"/></td> </tr> <tr> <td>(b) Hub/Wheel Bearing Seals (Any oil leaks)</td> <td><input type="checkbox"/></td> <td><input type="checkbox"/></td> </tr> <tr> <td>(c) Fluid and Air Leaks</td> <td><input type="checkbox"/></td> <td><input type="checkbox"/></td> </tr> <tr> <td>(d) Brake hoses, Pipes, Joints, Cables and Linkages</td> <td><input type="checkbox"/></td> <td><input type="checkbox"/></td> </tr> <tr> <td>(e) Foot Brake Warning Device (Heavy Vehicles)</td> <td><input type="checkbox"/></td> <td><input type="checkbox"/></td> </tr> <tr> <td>(f) Spring Brake (Heavy Vehicles)</td> <td><input type="checkbox"/></td> <td><input type="checkbox"/></td> </tr> <tr> <td>(g) Foot Brakes (Pedal Pressure)</td> <td><input type="checkbox"/></td> <td><input type="checkbox"/></td> </tr> <tr> <td>(h) Hand Brakes (Test)</td> <td><input type="checkbox"/></td> <td><input type="checkbox"/></td> </tr> </tbody> </table>	Condition of:	Good	Defective	(a) Brake Shoe Lining	<input type="checkbox"/>	<input type="checkbox"/>	(b) Hub/Wheel Bearing Seals (Any oil leaks)	<input type="checkbox"/>	<input type="checkbox"/>	(c) Fluid and Air Leaks	<input type="checkbox"/>	<input type="checkbox"/>	(d) Brake hoses, Pipes, Joints, Cables and Linkages	<input type="checkbox"/>	<input type="checkbox"/>	(e) Foot Brake Warning Device (Heavy Vehicles)	<input type="checkbox"/>	<input type="checkbox"/>	(f) Spring Brake (Heavy Vehicles)	<input type="checkbox"/>	<input type="checkbox"/>	(g) Foot Brakes (Pedal Pressure)	<input type="checkbox"/>	<input type="checkbox"/>	(h) Hand Brakes (Test)	<input type="checkbox"/>	<input type="checkbox"/>									
Check for:	Good	Defective																																												
(a) Severe body/chassis frame damage including corrosion	<input type="checkbox"/>	<input type="checkbox"/>																																												
(b) Cut and Joined bodies and chassis	<input type="checkbox"/>	<input type="checkbox"/>																																												
Condition of:	Good	Defective																																												
(a) Brake Shoe Lining	<input type="checkbox"/>	<input type="checkbox"/>																																												
(b) Hub/Wheel Bearing Seals (Any oil leaks)	<input type="checkbox"/>	<input type="checkbox"/>																																												
(c) Fluid and Air Leaks	<input type="checkbox"/>	<input type="checkbox"/>																																												
(d) Brake hoses, Pipes, Joints, Cables and Linkages	<input type="checkbox"/>	<input type="checkbox"/>																																												
(e) Foot Brake Warning Device (Heavy Vehicles)	<input type="checkbox"/>	<input type="checkbox"/>																																												
(f) Spring Brake (Heavy Vehicles)	<input type="checkbox"/>	<input type="checkbox"/>																																												
(g) Foot Brakes (Pedal Pressure)	<input type="checkbox"/>	<input type="checkbox"/>																																												
(h) Hand Brakes (Test)	<input type="checkbox"/>	<input type="checkbox"/>																																												
<p>8. Tyres/wheels</p> <table border="0"> <thead> <tr> <th>Condition of:</th> <th>Good</th> <th>Defective</th> </tr> </thead> <tbody> <tr> <td>(a) Tyres</td> <td><input type="checkbox"/></td> <td><input type="checkbox"/></td> </tr> <tr> <td>(b) Rims</td> <td><input type="checkbox"/></td> <td><input type="checkbox"/></td> </tr> <tr> <td>(c) Wheel Studs and Nuts</td> <td><input type="checkbox"/></td> <td><input type="checkbox"/></td> </tr> <tr> <td>(d) Tyre Inflated Pressure</td> <td><input type="checkbox"/></td> <td><input type="checkbox"/></td> </tr> <tr> <td>(e) Tyre Application</td> <td><input type="checkbox"/></td> <td><input type="checkbox"/></td> </tr> <tr> <td>(f) Wheel Alignment</td> <td><input type="checkbox"/></td> <td><input type="checkbox"/></td> </tr> </tbody> </table>	Condition of:	Good	Defective	(a) Tyres	<input type="checkbox"/>	<input type="checkbox"/>	(b) Rims	<input type="checkbox"/>	<input type="checkbox"/>	(c) Wheel Studs and Nuts	<input type="checkbox"/>	<input type="checkbox"/>	(d) Tyre Inflated Pressure	<input type="checkbox"/>	<input type="checkbox"/>	(e) Tyre Application	<input type="checkbox"/>	<input type="checkbox"/>	(f) Wheel Alignment	<input type="checkbox"/>	<input type="checkbox"/>																									
Condition of:	Good	Defective																																												
(a) Tyres	<input type="checkbox"/>	<input type="checkbox"/>																																												
(b) Rims	<input type="checkbox"/>	<input type="checkbox"/>																																												
(c) Wheel Studs and Nuts	<input type="checkbox"/>	<input type="checkbox"/>																																												
(d) Tyre Inflated Pressure	<input type="checkbox"/>	<input type="checkbox"/>																																												
(e) Tyre Application	<input type="checkbox"/>	<input type="checkbox"/>																																												
(f) Wheel Alignment	<input type="checkbox"/>	<input type="checkbox"/>																																												
<p>9. Suspension/Steering</p> <table border="0"> <thead> <tr> <th>Condition of:</th> <th>Good</th> <th>Defective</th> </tr> </thead> <tbody> <tr> <td>(a) Steering Ends and Linkages</td> <td><input type="checkbox"/></td> <td><input type="checkbox"/></td> </tr> <tr> <td>(b) Steering Box/Rack</td> <td><input type="checkbox"/></td> <td><input type="checkbox"/></td> </tr> <tr> <td>(c) Fluid Leak from Steering Box/Rack Power Hoses, etc.</td> <td><input type="checkbox"/></td> <td><input type="checkbox"/></td> </tr> <tr> <td>(d) Shackle Pin and Bushings</td> <td><input type="checkbox"/></td> <td><input type="checkbox"/></td> </tr> <tr> <td>(e) Suspension Rubber and Bushings</td> <td><input type="checkbox"/></td> <td><input type="checkbox"/></td> </tr> <tr> <td>(f) Stabilizer/Torsion Bars</td> <td><input type="checkbox"/></td> <td><input type="checkbox"/></td> </tr> </tbody> </table>	Condition of:	Good	Defective	(a) Steering Ends and Linkages	<input type="checkbox"/>	<input type="checkbox"/>	(b) Steering Box/Rack	<input type="checkbox"/>	<input type="checkbox"/>	(c) Fluid Leak from Steering Box/Rack Power Hoses, etc.	<input type="checkbox"/>	<input type="checkbox"/>	(d) Shackle Pin and Bushings	<input type="checkbox"/>	<input type="checkbox"/>	(e) Suspension Rubber and Bushings	<input type="checkbox"/>	<input type="checkbox"/>	(f) Stabilizer/Torsion Bars	<input type="checkbox"/>	<input type="checkbox"/>																									
Condition of:	Good	Defective																																												
(a) Steering Ends and Linkages	<input type="checkbox"/>	<input type="checkbox"/>																																												
(b) Steering Box/Rack	<input type="checkbox"/>	<input type="checkbox"/>																																												
(c) Fluid Leak from Steering Box/Rack Power Hoses, etc.	<input type="checkbox"/>	<input type="checkbox"/>																																												
(d) Shackle Pin and Bushings	<input type="checkbox"/>	<input type="checkbox"/>																																												
(e) Suspension Rubber and Bushings	<input type="checkbox"/>	<input type="checkbox"/>																																												
(f) Stabilizer/Torsion Bars	<input type="checkbox"/>	<input type="checkbox"/>																																												

LAWS OF TRINIDAD AND TOBAGO

Motor Vehicles and Road Traffic

Chap. 48:50

223

Motor Vehicles and Road Traffic Regulations

[Subsidiary]

APPENDIX VII

ORIGINAL

INSPECTOR'S TEST CERTIFICATE

Testing Centre No.
Name and Address of Inspector/Testing Site
Inspection No.

I HEREBY CERTIFY THAT—

- (1) I have personally made a thorough examination of, and have driven and tested
Motor Vehicle Reg. No. categorised as vehicle
Owner's Name
Owner's Address

Vehicle Particulars:

- (a) Chassis manufactured by Model
(b) Make and year manufactured VIN/Chassis No.
(c) Engine No. No. of Cylinders
(d) Fuel Horse Power Colour
(e) Tare kg M.G.W kg Tyre Size

and found the condition of its several parts to be:

Chassis
Engine
Body
Tyres
Brakes
Mechanism
Fittings

and have allowed a:

Longitudinal overhang of
Lateral overhang of
Rear Axle: Dual [] Dual Single []

- (2) The said vehicle/trailer conforms to the
Regulations for the time being in force under the Motor Vehicle and Road Traffic
Act, Ch. 48:50 and is in good and proper condition to carry
.....passengers.

LAWS OF TRINIDAD AND TOBAGO

224

Chap. 48:50

Motor Vehicles and Road Traffic

[Subsidiary]

Motor Vehicles and Road Traffic Regulations

APPENDIX VII—Continued

- (3) No more than persons may sit on the left/right of the driver and the vehicle may carry a maximum of passengers.
- (4) Inspection Receipt bearing No. dated, 20..... for the Inspection Fee paid at has been produced and seen by me.
- (5) And that the said vehicle Registration No. may be operated on the public roadways of Trinidad and Tobago for the period to

Date of Certificate, 20

.....
Signature of Officer/Examiner

LAWS OF TRINIDAD AND TOBAGO

Motor Vehicles and Road Traffic

Chap. 48:50

225

Motor Vehicles and Road Traffic Regulations

[Subsidiary]

APPENDIX VIII

INSPECTION STICKER

INSPECTION PASSED

MINISTRY OF WORKS AND TRANSPORT
TRANSPORT DIVISION

Jan		Jul
Feb		Aug
Mar		Sep
Apr		Oct
May		Nov
Jun		Dec

TRINIDAD & TOBAGO

Registration No.

Inspected

LAWS OF TRINIDAD AND TOBAGO

226

Chap. 48:50

Motor Vehicles and Road Traffic

[Subsidiary]

Motor Vehicles and Road Traffic Regulations

APPENDIX IX

EXAMINER'S ID

(FRONT)

TRANSPORT DIVISION

Approved Motor Vehicle Examiner

Name:

Expiry Date:

PHOTO

Badge No:

Certified by:

.....
Transport Commissioner

(BACK)

VEHICLE INSPECTION CLASSES:

CLASS 1 — Motorcycles

CLASS 3 — Private Motor Vehicles

(Not exceeding 2,270 kg)

This card is the property of the Transport Division, Ministry of Works and Transport. Duplication or modification of this card, or use by anyone rather than the Certified Examiner identified on this card, is a violation of the Motor Vehicle and Road Traffic Act, Ch. 48:50.

.....

LAWS OF TRINIDAD AND TOBAGO

Motor Vehicles and Road Traffic

Chap. 48:50

227

Motor Vehicles and Road Traffic Regulations

[Subsidiary]

APPENDIX X

**MINISTRY OF WORKS AND TRANSPORT
(TRANSPORT DIVISION)**

**APPLICATION FOR PREMISES TO BE USED AS A
VEHICLE TESTING OR INSPECTION COMPOUND**

(In Accordance with the Motor Vehicles and Road Traffic Act, Ch. 48:50 of the Laws of
Trinidad and Tobago)

INSTRUCTIONS:

- (a) Complete form accurately in capital letters or bold type.
- (b) Tick appropriate boxes to indicate area(s) of Interest.
- (c) Only persons owning twelve (12) vehicles and over would be considered as Fleet Owners.
- (d) Applications for Vehicle Testing Centres must be accompanied by a police certificate of character.
- (e) Persons wishing to offer their premises for use as a Testing Centre/Compound are required to carefully read the attached document "RESPONSIBILITIES OF AN AUTHORISED TESTER".
- (f) Approved premises for Testing would be subject to an annual fee.
- (g) Operators/Owners of approved Testing Centre/Compound would not be allowed to test their own vehicles at their Compound.

A. TYPE OF APPLICATION: Fleet Owner Compound Inspection
 Vehicle Testing Private Car Motorcycle

B. BUSINESS PARTICULARS:

- (a) Title/Name _____
- (b) Company Registration No. (c) VAT Registration No. (d)(i) Telephone No. ____
_____ (ii) Fax No. _____
- (e) Business Address _____
- (f) Compound Address _____
[If different from (a) above] _____

C. (FLEET OWNERS ONLY — Inspection would be conducted by Transport Division's Personnel)

- (a) No. of Vehicles _____
- (b) Registration Class (i) No. Motorcycle ____ (v) No. Extra Heavy Motor Vehicle ____
(MGW over 15240 kg)
(ii) No. Wheel Tractor ____ (vi) No. Omnibus _____
(iii) No. Light Motor Vehicle _____ (vii) No. Trailer:
(MGW 2940 kg and over) _____
(iv) No. Heavy Motor Vehicle ____ (viii) No. of Other Vehicle ____
Agriculture _____ Industrial _____

LAWS OF TRINIDAD AND TOBAGO

228

Chap. 48:50

Motor Vehicles and Road Traffic

[Subsidiary]

Motor Vehicles and Road Traffic Regulations

- (c) Have you applied for Fleet Owner Compound Inspection previously?
 Yes No
- (d) Have you been granted Fleet Owner Compound Inspection approval previously?
 Yes No
- (e) If answer to (d) is "Yes" state period(s) _____

D. (VEHICLE TESTING ONLY—Testing to be conducted by Private Garage Personnel on Private Cars and Motorcycles)

- (a) List all work/functions presently performed at Testing Compound _____

- (b) State Mechanical Qualifications/Training/Experience of Owner Tester(s)

E. COMPOUND FACILITIES

- (a) Accommodation: (i) Staff Yes No (iii) Parking Yes No
 (ii) Brake Test Area Yes No (iv) Wash Rooms
 Yes No
- (b) Equipment _____

- (c) Inspection Pit: Dimension (i) Width _____ (iii) Depth _____
 (ii) Length _____ (iv) Height _____
- (d) Ramp/Other _____

F. SIGNATURE _____ **DATE** _____

FOR OFFICIAL USE

Date Received _____ Date Referred To Assessment Committee _____

Committee's Recommendation: Approved Not Approved Date Referred to
Transport
Commissioner _____

TRANSPORT COMMISSIONER'S DECISION APPROVED NOT APPROVED

Signature of Transport Commissioner

Date

LAWS OF TRINIDAD AND TOBAGO

Motor Vehicles and Road Traffic

Chap. 48:50

229

Motor Vehicles and Road Traffic Regulations

[Subsidiary]

APPENDIX XI

APPLICATION FOR INSPECTION DOCUMENTS

- 1. NAME OF VEHICLE TESTING STATION:
2. ADDRESS:
3. NAME OF OWNER:
4. ADDRESS (IF DIFFERENT FROM ABOVE):
5. VEHICLE TESTING STATION NO.:
[] Inspection Checklist
[] Certificate of Inspection
[] Inspection Sticker
[] Monthly Return
[] Grievance/Complaint Notice

I hereby apply for the issue of the above Inspection documents for use at the Vehicle Testing Station named above.

Signature of Owner/Proprietor

Date

For Official Use Only

Cashier,

Please accept the sum of ... for the purchase of ...
Document details: Inspection Checklist Nos. ... to ...
Certificate of Inspection Nos. ... to ...
Inspection Sticker Nos. ... to ...
Monthly Return Nos. ... to ...

For Transport Commissioner

LAWS OF TRINIDAD AND TOBAGO

Motor Vehicles and Road Traffic

Chap. 48:50

231

Motor Vehicles and Road Traffic Regulations

[Subsidiary]

APPENDIX XIII

MINISTRY OF WORKS AND TRANSPORT

COMPLAINT/GRIEVANCE NOTICE

NAME

ADDRESS

.....

Phone No.

Complaint/Grievance (Give outline and essential facts below)

.....
.....
.....
.....
.....

Date

Signature

LAWS OF TRINIDAD AND TOBAGO

232

Chap. 48:50

Motor Vehicles and Road Traffic

[Subsidiary]

Motor Vehicles and Road Traffic Regulations

(Regulation
27C).

SEVENTH SCHEDULE

PART I

PRIVATE GARAGE SIGN:

“MINISTRY OF WORKS AND TRANSPORT

TRANSPORT DIVISION

APPROVED MOTOR VEHICLE TESTING STATION

NO.”.

The sign shall be 48" x 52"; the colour shall be white lettering on a black background; and the material shall be Scotch Lite Reflecting Sheeting. The sign shall be mounted on a round steel post.

PART II

CONDITIONS AS TO ERECTION OF PRIVATE GARAGE SIGN

1. The sign shall be securely fixed against a wall of the vehicle testing station.
2. The sign shall be so exhibited that no part thereof is above the fascia level of the vehicle testing station or above fifteen feet from the ground, whichever is the lower.
3. Not more than one sign shall be displayed on each road frontage.

SAFETY HELMETS NOTIFICATION

137/1978.

made under section 43(3)

The Minister hereby prescribes [as helmets capable of affording the head of the wearer protection from injury in the event of an accident, within the meaning of section 43(3) of the Act] safety helmets which, in design, construction and other quality, comply and carry the appropriate mark of compliance with any of the following standards:

American National Standard ...	290.1-1971	Specifications for protective headgear for vehicle users.
Australian Standard ...	AS 1698-1974	Protective Helmets for vehicle users.
British Standard ...	BS 2001	Protective Helmets for motor cyclists.
British Standard ...	BS 2495-1977	Protective Helmets for vehicle users (high protection).
British Standard ...	BS 5361-1976	Protective Helmets for vehicle users.
Canadian Standard ...	CSA D230-1970	Safety Helmets for motorcycle riders.
Emergency Indian Standard ...	IS:4151E-1968	Safety Helmets for road users.
International Standards Organisation ...	ISO/R1511-1970	Protective Helmets for road users.
Swedish Standard ...	SIS 88 24 11-1976	Protective Helmets for road users. Requirements.

LAWS OF TRINIDAD AND TOBAGO

234 **Chap. 48:50** *Motor Vehicles and Road Traffic*

[Subsidiary]

210/1979.

SPECIAL SPEED LIMITS ORDER

made under section 62(2)

Citation.

1. This Order may be cited as the Special Speed Limits Order.

Speed limits.

2. The special speed limits specified in the fourth column of the Schedule are hereby imposed with respect to the roads specified in the first column of the said Schedule in relation to the classes or descriptions of motor vehicles specified in the second column and during the periods specified in the third column of the said Schedule.

SCHEDULE

	Road	Class or Description of Motor Vehicle	Time	Special Speed Limit kilometres per hour
1	The Priority Bus Route	All classes of authorised vehicles	at all times	65
2	<i>Lady Young Road</i> in the County of St. George from a point of intersection with the Eastern Main Road to the 3-kilometre post, <i>Lady Young Road</i> from the 6-kilometre post to the junction of the St. Ann's Road	All motor vehicles except a tractor, and in this provision tractor does not include a goods vehicle or private motor car with or without trailer	at all times	50
3	That part of the Eastern Main Road situated in the County of St. George West which starts from a point 45 metres West of Sixth Avenue and continuing to a point 45 metres East of the said avenue	All motor vehicles except a tractor, and in this provision tractor does not include a goods vehicle or private motor car with or without trailer	from 6.00 a.m. to 6.00 p.m. daily	25

LAWS OF TRINIDAD AND TOBAGO

Motor Vehicles and Road Traffic

Chap. 48:50

235

Special Speed Limits Order

[Subsidiary]

	Road	Class or Description of Motor Vehicle	Time	Special Speed Limit kilometres per hour
4	That part of the Paria Main Road situated in the County of St. George, which passes through Maracas Bay, commencing with the 130-kilometre mark and running in a more or less westerly direction for a distance of 755 metres to the junction of the said road with the North Coast Road	Motor vehicles generally	at all times	25
5	That part of the Manzanilla - Mayaro Road situated in the Ward of Turure in the County of St. Andrew, which passes through the Cocal Estate Compound, commencing with the 70-kilometre mark and running in a more or less southerly direction for a distance of 400 metres to the 70-kilometre mark on the said road	(a) Tractor (except a goods vehicle or private motor car with or without a trailer)	at all times	15
		(b) Any other motor vehicle	at all times	25
6	Mayaro Beach in the County of Mayaro and Manzanilla Beach in the Counties of St. Andrew and St. David	Motor vehicles generally	at all times	25

[Subsidiary]

209/1979.

SPEED LIMITS (BUILT-UP AREAS) ORDER

made under section 62(2)

Citation. **1.** This Order may be cited as the Speed Limits (Built-up Areas) Order.

Built-up areas. **2.** The roads or portions of roads specified in the Schedule are hereby declared to be built-up areas for the purposes of section 62 of the Act.

SCHEDULE

1. All roads in that area bounded as follows:
 - (a) North—by a line running due East and West of the two-kilometre post on the Saddle Road;
 - (b) South—by the Churchill-Roosevelt Highway from its intersection with the Eastern Main Road and thence by its northern boundary eastward;
 - (c) East—by the Mausica Road;
 - (d) West—by the western boundary of the City of Port-of-Spain.
2. All roads in that area bounded as follows:
 - (a) North—from the Bridge on the Maraval River at the north-eastern end of Jamaica Boulevard thence in a westerly direction to a drain running along the southern boundary of Ellerslie Park and continuing due West along the said drain through lands leased to the entrance to Civil Service Association Club;
 - (b) South—thence in an easterly direction along the said drain to Jamaica Boulevard and running South along the western side of Jamaica Boulevard to the Maraval River;
 - (c) East—continuing in a northerly direction along the Maraval River to the point of commencement;
 - (d) West—continuing in a southerly direction along Long Circular Road to Barbados Road and eastwards along the southern side of Barbados Road to and along a drain running along the eastern boundary of the St. James Barracks to another drain at the north-western boundary of St. Mary's College Grounds.
3. Western Main Road from the junction of the Diego Martin Main Road, Cocorite to the western end of Scotland Bay.

LAWS OF TRINIDAD AND TOBAGO

Motor Vehicles and Road Traffic

Chap. 48:50

237

Speed Limits (Built-Up Areas) Order

[Subsidiary]

4. Long Circular Road.
5. Saddle Road.
6. Diego Martin Main Road.
7. Beetham Highway from the one and a half-kilometre mark to the two-kilometre mark.
8. St. Ann's Road—from its intersection with the Lady Young Road to the Simon Valley Road.
9. Coblantz Avenue—from its intersection with St. Ann's Road to its intersection with Cascade Road.
10. Cascade Road—from its intersection with St. Ann's Road to Knightsbridge.
11. Eastern Main Road—from its intersection with the boundary of the City of Port-of-Spain to the thirty-kilometre post on the Eastern Main Road.
12. North Coast Road.
13. Morne Coco Road.
14. All roads in St. Joseph bounded as follows:
 - North and East—by the St. Joseph River.
 - South—by the Eastern Main Road.
 - West—by a straight line running from the culvert on the Eastern Main Road near the entrance to the old Railway Station in a northerly direction to the ford of the St. Joseph River on the road to Maracas nearest to the Town of St. Joseph.
15. All roads in Tunapuna bounded as follows:
 - North—Northern boundary of Chinab's land and a line running due East and West from that line.
 - South—Railway line.
 - East—Back Street (East) and a line running due North and South from that street.
 - West—The boundary of the area formerly known as St. Joseph's Ward.
16. Arima-Blanchisseuse Road.
17. The Eastern Main Road from Guaico to Sangre Grande (i.e., from the forty-five-kilometre mark to the fifty-kilometre mark).

18. All roads in Sangre Grande bounded as follows:

North—A line drawn from the north-eastern boundary of block of six hectares of land, the property of the heirs of C. F. Sellier, crossing the Warner or Cuare Road and running in a westerly direction along the northern boundary of the said block and the northern boundary of lands of Rampersad, Jeebodh and Sookaie to the Picton Trace.

South—The Cunapo River.

East—A line drawn from the Cunapo River along the eastern boundary of a four hectares block of land formerly the property of A. Brooks, now of the heirs of C. F. Sellier crossing the Sangre Grande-Oropouche Road and along the eastern boundary of a two and a half hectares block of land formerly the property of P. Ojoe, now of the heirs of C. F. Sellier and thence in a northerly direction to the northern boundary of the lands of J. Ojoe now F. Cumberbatch, thence in a westerly direction to the southeastern corner of a one and a half hectares block of land the property of the heirs of C. F. Sellier, thence running North along the eastern boundary of the said one and a half hectares block of land and lands of M. Warner now of Philip Acham and lands of heirs of C. F. Sellier (six hectares) to the north-eastern boundary of the said block of land.

West—A line drawn along the Picton Trace to the Eastern Main Road, and thence in a straight line running South to the Cunapo River.

19. The portion of the Paria Main Road between Toco and Matelot.

20. The portion of the Toco Main Road, in the County of St. David commencing at the four-kilometre post and ending at the six-kilometre post.

21. Manzanilla Beach Road.

22. Manzanilla-Mayaro Road from the Eastern Main Road to the southern side of the Nariva Bridge.

23. That portion of the Manzanilla-Mayaro Road commencing at the eighty-five-kilometre mark and ending at the eighty-five-kilometre mark on the said Manzanilla-Mayaro Road.

24. Cunapo Southern Road—

(a) in the County of St. Andrew, between the four-kilometre mark and the ten-kilometre mark; and

(b) in the County of Nariva, between the twenty-five-kilometre mark and the thirty-five-kilometre mark.

25. Caroni South Bank Road, Kelly Village, County of Caroni between the two-kilometre mark and St. Helena Junction.

LAWS OF TRINIDAD AND TOBAGO

26. Caroni Savannah Road from Chaguanas to its junction with the South Trunk Road, Charlieville.

27. All roads lying within the radius of two kilometres of the Magistrate's Court, Chaguanas.

28. Southern Main Road, County of Caroni, between the nine-kilometre mark and the fifteen-kilometre mark.

29. Chaguanas Main Road in the County of Caroni.

30. Cacandee Road, Chaguanas in the County of Caroni.

31. Southern Main Road, one hundred and eighty-five metres East of Calcutta Road No. 3 (Deonarine Junction) in the County of Caroni.

32. Southern Main Road, four hundred and seventy-five metres West of Calcutta Road No. 3 (Deonarine Junction) in the County of Caroni.

33. Southern Main Road, one hundred and eighty-five metres East of St. Marys' Junction, Freeport in the County of Caroni.

34. Southern Main Road, one hundred and eighty-five metres West of St. Marys' Junction, Freeport in the County of Caroni.

35. Southern Main Road—from the thirty-five-kilometre mark to the forty-kilometre mark (i.e., that portion of the Southern Main Road which passes through California Village).

36. Southern Main Road—

- (a) from its junction with the Churchill-Roosevelt Highway to the ten-kilometre post or mark;
- (b) from its junction with the Princess Margaret Highway to the twenty-five-kilometre post or mark;
- (c) from the forty-five-kilometre post or mark to the boundary of the Borough of San Fernando.

37. Couva bounded as follows:

North—By a line parallel to the Couva Main Road running from the Waterloo Road to the north-western corner of the Anglican Church Lands, then running along the northern boundary of the Anglican Church Lands to the north-eastern corner of the said lands, thence in a straight line to the north-western corner of the Glebe Lands, three hectares, thence in an easterly direction along the northern boundary of the Glebe Lands crossing Carlos Street to a point on

LAWS OF TRINIDAD AND TOBAGO

240

Chap. 48:50

Motor Vehicles and Road Traffic

[Subsidiary]

Speed Limits (Built-Up Areas) Order

the eastern boundary of an estate trace; thence in a northerly direction along the eastern boundary of the said trace to a point at its intersection with the southern boundary of the so-called Perseverance Exchange Road, thence easterly along the southern boundary of the said road to the junction of Exchange Road, thence in a general southerly direction along the western boundary of the said road to the north-eastern corner of the parcel of land now or formerly owned by H. L. Jobitt; thence in a due East direction crossing the Exchange Road and the Trinidad Government Railway line to a point on the western boundary of the Southern Main Road.

South—By a due West line running from the southern extremity of the eastern boundary on the Couva River to a point lying due South of the junction of the Couva River and Waterloo Roads.

East—By the Southern Main Road, Isaac Street and a due South line from the southern end of Isaac Street to the Couva River.

West—By the Waterloo Road and by a line running due South from the junction of this road with the Couva River Road to the western end of the southern boundary.

38. That portion of the Southern Main Road, commencing at its intersection with the boundary of the Borough of San Fernando on its southern side, and thence running in a southerly direction and ending at the sixty-kilometre mark.

39. The San Fernando-Siparia-Erin Road at its intersection with Ramsamooj Trace, and thence running in a southerly direction and ending at the Mohess Road Junction.

40. That portion of the San Fernando-Siparia-Erin Road between the five-kilometre mark in the County of Victoria and the forty-kilometre mark in the County of St. Patrick.

41. Guaracara-Tabaquite Road from the junction with the Southern Main Road, Marabella, to a point one hundred and fifty-five metres east of the Harmony Hall Road.

42. From the intersection of Bonne Aventure Road and Charles Street to a point East adjacent to the four-kilometre post on Bonne Aventure Road.

43. The entire length of Harmony Hall Road from the intersection of the Guaracara-Tabaquite Road to the Bonne Aventure Road.

44. Princes Town bounded as follows:

North—by the southern boundary of the Malgretoute Estate from the point where it leaves the eastern boundary of the Cedar Hill Estate to the old Cipro Tramline, thence along the old Cipro Tramline to the Glenroy Estate

boundary on the Naparima-Mayaro Road, thence along the southern boundary of the Glenroy Estate to the north-western corner of the Birken Hill Estate which now forms part of Buen Intento Estate.

South—by the northern boundary of the Lothians Estate from the south-eastern corner of the Navette public burial ground to the south-eastern corner of the Cedar Hill Estate.

East—by the western boundary of the said Birken Hill Estate to the north-western corner of the Knolly's Recreation Ground, thence along the northern and eastern boundaries of Knolly's Recreation Ground and the southern boundary of the said Birken Hill Estate to the western boundary of the Craignish Estate and along the western boundary of the said Craignish Estate to the Naparima-Mayaro Road and along that road in a south-westerly direction to the western boundary of the Brommage Estate and along that boundary to where it meets the eastern boundary of the Lothians Estate, thence in a straight line running in a more or less south-westerly direction to the south-eastern corner of the Navette public burial ground.

West—by the eastern boundary of the Cedar Hill Estate from its south-eastern corner to the point where it meets the southern boundary of the Malgretoute Estate.

45. Manahambre Road commencing at the three-kilometre mark of the Naparima-Mayaro Road and thence running in a south-easterly direction for a distance of four kilometres to the junction with St. Charles Road and thence continuing in a north-easterly direction ending at its junction at the twelve-kilometre mark of the Naparima-Mayaro Road in the County of Victoria.

46. Naparima-Mayaro Road from the twenty-five-kilometre post or mark to the thirty-kilometre post or mark.

47. All roads lying within a radius of two kilometres of the Police Station, Oropouche.

48. All roads lying within a radius of three kilometres of the junction of the Fyzabad Road with the Fyzabad-Guapo Road.

49. Clarke Road in the County of St. Patrick and all roads lying within a radius of five kilometres of the Penal Police Station.

50. All roads lying within a radius of three-kilometres of the Magistrate's Court, Siparia.

51. That portion of the Southern Main Road in the Vessigny Area commencing at the eighty-kilometre post and ending at the ninety-kilometre post.

LAWS OF TRINIDAD AND TOBAGO

242

Chap. 48:50

Motor Vehicles and Road Traffic

[Subsidiary]

Speed Limits (Built-Up Areas) Order

52. Southern Main Road, Rousillac Village, La Brea, between the seventy and the seventy-five-kilometre marks, in the County of St. Patrick.

53. All roads lying within a radius of three kilometres of the Police Station, Point Fortin.

54. All roads lying within a radius of two kilometres from the Rest House at Cedros.

55. That portion of Fullerton Road, Icacos, which lies between Columbia Road on the West and Fullerton Beach on the East.

56. Southern Main Road, Fullerton—from a point approximately one hundred and eighty-five metres West of the one hundred and twenty kilometre-mark and continuing in a westerly direction to a point one hundred and eighty-five metres West of the one hundred and twenty-kilometre mark.

57. The entire Fullerton Beach Road from the Southern Main Road to the Beach.

58. Mayaro-Guayaguayare Road—from nought to the seven-kilometre mark and from the fifteen-kilometre mark to the twenty-kilometre mark.

59. All roads in the Island Ward of Tobago.

SPECIAL SPEED LIMITS (BRIDGES) ORDER

46/1957.

made under section 62(3)

1. (1) This Order may be cited as the Special Speed Limits (Bridges) Order. Citation and commencement.

(2) This Order shall come into operation on the date of commencement of the Motor Vehicles and Road Traffic (Amendment) Ordinance 1956.

2. The special speed limits specified in the second column of the Schedule are hereby imposed in respect of the bridges over which roads pass, which bridges and roads are specified in the first column of the said Schedule, in relation to motor vehicles generally Speed limits.

SCHEDULE

<i>Bridges and Roads</i>	<i>Special Speed Limit (kilometres per hour)</i>
1. COUNTY OF ST. GEORGE	
(a) B1/2—Saddle Road	15
(b) B1/5—Maracas Royal Road	15
2. COUNTY OF CARONI	
B1/14 over Honda River—Southern Main Road	15
3. COUNTY OF ST. ANDREW	
(a) B1/37—Eastern Main Road	15
(b) Nariva Bridge—75-kilometre mark Manzanilla-Mayaro Road	10
4. COUNTY OF VICTORIA	
(a) B1/1—Harmony Hall Road	15
(b) B3/6—San Fernando-Siparia-Erin Road	10
(c) B1/41—Godineau Bridge—Southern Main Road	15
5. COUNTY OF NARIVA-MAYARO	
B3/2—Rio Claro-Guayaguayare Road	15

LAWS OF TRINIDAD AND TOBAGO

244 **Chap. 48:50** *Motor Vehicles and Road Traffic*

[Subsidiary]

206/1979*.

ROAD TRAFFIC (PROHIBITED PARKING) ORDER

made under section 65

Citation.

1. This Order may be cited as the Road Traffic (Prohibited Parking) Order.

Parking of vehicle.

2. (1) No person shall cause or permit any vehicle to be or to remain parked on any of the roads specified in the First Schedule.

(2) No person shall cause or permit any vehicle to be or to remain parked on a road described in the first column of the Second Schedule on the days and, where applicable, during the hours specified in the second column of the said Schedule.

Offence.
[47 of 1980].

3. Any person who contravenes the provisions of clause 2 is liable on summary conviction to a fine of five hundred dollars or to imprisonment for three months.

FIRST SCHEDULE

PART A

COUNTY OF CARONI

1. Chaguanas Main Road between the Southern Main Road Junction and the South-bound Overpass on the Solomon Hochoy Highway.

2. The surfaced portion of the Princess Margaret Highway from the Caroni River Bridge to the Chaguanas Overpass.

PART B

COUNTY OF MAYARO

ROAD

1. Naparima-Mayaro Road from its junction with Pierreville Village Street and extending in an easterly direction to a point 45 metres East of its junction with Manzanilla-Mayaro Road.

*This Order has been amended by the following: 220/1980; 148/1983; 117/1984; 75/1985; 114/1985; 138/1986 and 184/1986.

LAWS OF TRINIDAD AND TOBAGO

Motor Vehicles and Road Traffic

Chap. 48:50

245

Road Traffic (Prohibited Parking) Order

[Subsidiary]

2. Manzanilla-Mayaro Road from its junction with Naparima-Mayaro Road and extending in a northerly direction for a distance of 45 metres.

3. Peter Hill Trace from its junction with Naparima-Mayaro Road and extending in a northerly direction for a distance of 50 metres.

4. Guayaguayare Road from its junction with Naparima-Mayaro Road and extending in a southerly direction to a point 10 metres South of the Mayaro Post Office.

PART C

COUNTY OF NARIVA

ROAD

Rio Claro-Tabaquite Road from its junction with Naparima-Mayaro Road and extending in a northerly direction for a distance of one hundred metres.

PART D

COUNTY OF ST. ANDREW

ROAD

1. Eastern Main Road from its junction with Toco Road at the Roundabout and extending in a southerly direction for a distance of 185 metres.

2. Eastern Main Road from its junction with Ojoe Road at the Roundabout and extending in a westerly direction to the junction of Picton Road.

3. Andre Street between Cunapo Southern Road and Eastern Main Road.

4. Cunapo Southern Road between Eastern Main Road and Mary Street.

5. Mary Street between Cunapo Southern Road and George Street.

6. George Street between Eastern Main Road and Mary Street.

7. Toco Road from its junction with Eastern Main Road at the Roundabout and extending in an easterly direction to the junction of Henderson Street.

8. Brierley Street between Riverside Extension Road and Foster Local Road, between 6.00 a.m. and 6.00 p.m. daily, Sundays and Public Holidays not included.

9. Old Railway Road West, from its junction with Eastern Main Road and Riverside Extension Road.

LAWS OF TRINIDAD AND TOBAGO

246

Chap. 48:50

Motor Vehicles and Road Traffic

[Subsidiary]

Road Traffic (Prohibited Parking) Order

PART E

COUNTY OF ST. DAVID

NIL

PART F

COUNTY OF ST. GEORGE EAST

ROAD

1. Golden Grove Road from the intersection of the Churchill-Roosevelt Highway to a point sixty metres East of the exit gate of the Piarco International Airport.
2. Southern Main Road, Curepe, from its junction South of the Churchill-Roosevelt Highway to a point four hundred and sixty metres in a southerly direction.
3. Southern portion of Broadway in the Borough of Arima from a point twenty-five metres East of Queen Street.
4. Cocorite Street in the Borough of Arima between Broadway and Green Street.
5. Queen Street in the Borough of Arima from Broadway to a point sixty metres South.
- 5A. Queen Street, eastern side between Farfan Street and Devenish Street.
6. The surfaced portion of the Churchill-Roosevelt Highway.
7. The surfaced portion of the Princess Margaret Highway from its junction with the Churchill-Roosevelt Highway to the Caroni River Bridge.

PART G

COUNTY OF ST. GEORGE WEST

ROAD

1. Lady Chancellor Road in the Ward of St. Ann's between the eight hundred-metre post from its junction with Circular Road to the three-kilometre post.
2. Cascade Road, St. Ann's between Spring Bank Avenue and Walker Avenue.

LAWS OF TRINIDAD AND TOBAGO

Motor Vehicles and Road Traffic

Chap. 48:50

247

Road Traffic (Prohibited Parking) Order

[Subsidiary]

3. Nook Avenue, situate at St. Ann's.
4. La Fantasie Road in the Ward of St. Ann's.
5. Reid Lane, Belmont, in the City of Port-of-Spain between Belmont Circular Road and Norfolk Street.
6. Albion Street between Dundonald Street and Stanmore Avenue in the City of Port-of-Spain.
7. Melville Lane in the City of Port-of-Spain.
8. Gordon Street between Pembroke Street and Frederick Street in the City of Port-of-Spain.
9. Fitzgerald Lane in the City of Port-of-Spain.
10. Darbain Lane in the City of Port-of-Spain.
11. New Street between Frederick Street and Pembroke Street in the City of Port-of-Spain.
12. Frederick Street between New Street and Gordon Street in the City of Port-of-Spain.
13. Pembroke Street between Gordon Street and New Street in the City of Port-of-Spain.
14. Park Street between Piccadilly Street and Charlotte Street in the City of Port-of-Spain.
15. Charlotte Street between Observatory Street and Park Street in the City of Port-of-Spain.
16. Edward Street from a point ninety metres South of the intersection of Sackville and Edward Streets extending further South to a point one hundred metres South of the said intersection in the City of Port-of-Spain.
17. Edward Street, Port-of-Spain, from a point commencing five metres South of vehicle entrance of "Trinidad House" and continuing to a point five metres North of the said entrance.
18. Edward Street, Port-of-Spain, between Independence Square North and Independence Square South.
19. Richmond Street between Fraser Street and Park Street in the City of Port-of-Spain.

LAWS OF TRINIDAD AND TOBAGO

248

Chap. 48:50

Motor Vehicles and Road Traffic

[Subsidiary]

Road Traffic (Prohibited Parking) Order

20. Queen Street in the City of Port-of-Spain between Frederick Street and Chacon Street.

21. Harvey Street in the City of Port-of-Spain.

22. The surfaced portion of the Beetham Highway situated in the Ward of St. Ann's not including that portion appearing under Part "G" of the First Schedule to the Miscellaneous Roads (Unilateral Parking) Order.

23. Wrightson Road between Edward and St. Vincent Streets in the City of Port-of-Spain.

24. Long Circular Road in the Ward of St. Ann's between Patna Street and Dibe Road.

25. Long Circular Road, Maraval, in the City of Port-of-Spain at the entrance of Camp Ogden, from points ten metres North and South of the said entrance.

26. Tragarete Road in the City of Port-of-Spain between Damian Street and the western end of Serpentine Road.

27. Lucknow Street between Hyderabad Street and Panka Street in the City of Port-of-Spain.

28. Panka Street between Lucknow Street and Gaston-Johnston Street in the City of Port-of-Spain.

29. Delhi and Kathleen Streets, St. James.

30. Morne Coco Road ninety metres North and South of the Crystal Stream Avenue in the Ward of Diego Martin.

31. Western Main Road commencing at the twelve-kilometre post or mark and ending a distance of one and a half kilometres, measured along the said Road, West of that post or mark in Carenage.

32. Quarry-Prizgar Road between Old St. Joseph Road and a point two hundred and seventy-five metres North of Old St. Joseph Road through Prizgar Lands.

33. Jogie Road in the Ward of St. Ann's between Fifth Street, Barataria and the Eastern Main Road.

34. First Street, San Juan, in the Ward of St. Ann's between Second Street and a point one hundred and forty metres North of Second Street.

LAWS OF TRINIDAD AND TOBAGO

Motor Vehicles and Road Traffic

Chap. 48:50

249

Road Traffic (Prohibited Parking) Order

[Subsidiary]

35. Second Street, San Juan, in the Ward of St. Ann's between Saddle Road and First Avenue, not including those portions appointed as Taxi Stands.

36. Real Street, San Juan, in the Ward of St. Ann's between Saddle Road and San Juan Street.

37. Saddle Road, San Juan, in the Ward of St. Ann's between Eastern Main Road and Mission Road.

38. Saddle Road, North of the fifteen-kilometre post for a distance of one hundred and sixty-five metres in the Ward of St. Ann's.

38A. Mission Road, San Juan in the Ward of St. Ann's between Saddle Road and Rosemin Drive.

39. Mount Lambert Circular Road in the Ward of St. Ann's between the Priority Bus Route and First Avenue.

40. The surfaced portion of the Churchill-Roosevelt Highway.

41. Duke Street between Melbourne Street and Richmond Street, in the City of Port-of-Spain.

42. Production Avenue, Sea Lots, Port-of-Spain.

42A. Hayes Street, St. Clair—southern side between Elizabeth Street and Alexandra Street.

43. Sierra Leone Road between the Diego Martin Main Road and St. Lucien Road.

44. St. Lucien Road between Sierra Leone Road and Majuba Cross Road.

PART H

COUNTY OF ST. PATRICK

ROAD

Oropouche Road situated between the junction of the said road with the Delhi Settlement Road and the Fyzabad Road.

PART I

TOBAGO

ROAD

1. Carrington Street from the junction of Burnett Street to Crooks River Bridge, Scarborough.

LAWS OF TRINIDAD AND TOBAGO

250

Chap. 48:50

Motor Vehicles and Road Traffic

[Subsidiary]

Road Traffic (Prohibited Parking) Order

2. Bacolet Street from the junction of Main Street to the southern end of the New County Hall, Scarborough.

3. Bacolet Street, Tobago, from a point ninety metres East of the entrance to the Temporary Court House and Police Station extending in a westerly direction for a distance of one hundred and eighty-five metres, Scarborough.

4. North Side Road from Crooks River Bridge to the southern side of the Botanic Station, Scarborough.

5. Wilson Road between Milford and Darrel Spring Roads, Scarborough.

PART J

COUNTY OF VICTORIA

ROAD

1. Court Street between Lewis Street and Harris Street, San Fernando.

2. *(Deleted by LN 152/1981).*

3. Circular Road, from a point ninety metres East of London Street to a point ninety metres West of London Street, San Fernando.

4. Penitence Street between High Street and San Fernando Street, San Fernando.

5. Penitence Street between Court Street and Harris Promenade (North), San Fernando.

6. Lord Street between Coffee Street and Mucurapo Street, San Fernando.

7. Mon Chagrin Street between High Street and St. James Street, San Fernando.

8. Hollis Street, San Fernando.

9. Paradise Street, San Fernando.

10. Hubert Rance Street between Vistabella Road and a point one hundred and eighty-five metres North of Boodoosingh Street, San Fernando.

11. St. James Street between Penitence Street and High Street, San Fernando.

12. Ciperio Street between Coffee Street and a point thirty-five metres South of Coffee Street, San Fernando.

LAWS OF TRINIDAD AND TOBAGO

Motor Vehicles and Road Traffic

Chap. 48:50

251

Road Traffic (Prohibited Parking) Order

[Subsidiary]

13. Coffee Street between Library Corner and a point forty-five metres East of Johnstone Street, San Fernando.

14. Keate Street between Prince Alfred Street and Gransaul Street, San Fernando.

15. Chancery Lane, San Fernando.

16. Mucurapo Street between Lord Street and Library Corner, San Fernando.

17. Quenca Street between San Fernando Street and High Street, San Fernando.

18. Pointe-a-Pierre Road between High Street and Short Street, San Fernando.

19. Pointe-a-Pierre Road between a point thirty metres North of Mount Moriah Road and a point thirty metres North of Chacon Street, San Fernando.

20. Scott Street between Cipero Street and Villian Street, San Fernando.

21. La Pique Road, San Fernando.

22. Cemetery Street in the Borough of San Fernando between Harris Promenade and Lord Street.

23. Independence Avenue, San Fernando between Keate Street and Harris Promenade.

24. Southern Main Road from Cross Crossing to the Union Roundabout, San Fernando.

25. Guaracara-Tabaquite Road between Southern Main Road and a point forty-five metres eastwards, San Fernando.

26. San Fernando Bye-Pass, in the Ward of Naparima, which commences at the fifty-kilometre mark, Southern Road (the Marabella Roundabout) and ends at the fifty-five-kilometre mark on the said Southern Road (the Union Hall Roundabout), San Fernando.

LAWS OF TRINIDAD AND TOBAGO

252

Chap. 48:50

Motor Vehicles and Road Traffic

[Subsidiary]

Road Traffic (Prohibited Parking) Order

SECOND SCHEDULE

COUNTY OF ST. GEORGE WEST

- | | |
|--|---|
| 1. St. Joseph Road in the City of Port-of-Spain | Monday to Friday
between 6.00 a.m. and 9.00 a.m. |
| 2. Independence Square South in the City of Port-of-Spain | Monday to Friday
between 6.00 a.m. and 9.00 a.m. |
| 3. Church Street, St. James, between Brunton Road and Bournes Road | Monday to Friday
between 6.00 a.m. and 6.00 p.m. |

TOBAGO

- | | |
|---|---|
| 1. Piggott Street between Bacolet and Jerningham Streets, Scarborough | between 6.00 a.m. and 6.00 p.m. |
| 2. Burnett Street South of Main Street, Scarborough | between 6.00 a.m. and 6.00 p.m. |
| 3. Burnett Street from the junction of Carrington Street to Main Street, Scarborough | between 6.00 a.m. and 6.00 p.m. |
| 4. Castries Street from the junction of Carrington Street to Main Street, Scarborough | between 6.00 a.m. and 6.00 p.m. |
| 5. Mount Marie Road, Scarborough | between 6.00 a.m. and 9.00 p.m.
and
between 3.00 p.m. and 6.00 p.m. |
-

LAWS OF TRINIDAD AND TOBAGO

Motor Vehicles and Road Traffic

Chap. 48:50

253

[Subsidiary]

**MISCELLANEOUS ROADS
(UNILATERAL PARKING) ORDER**

207/1979.
[220/1980
75/1985].

made under section 65

1. This Order may be cited as Miscellaneous Roads (Unilateral Parking) Order. Citation.

2. No person shall cause or permit a vehicle to be or to remain parked on any road described in the first column of the Schedule on the side of such road and, where applicable, on the days or at the times mentioned in the second column of the said Schedule. Parking of vehicle.

3. Any person who contravenes any of the provisions of clause 2 is liable on summary conviction to a fine of five hundred dollars or to imprisonment for three months. Offence.

SCHEDULE

PART A

COUNTY OF CARONI

Nil

PART B

COUNTY OF MAYARO

Nil

PART C

COUNTY OF NARIVA

Road

Side of Road

1. Naparima-Mayaro Road from its junction with Rio Claro-Tabaquite Road and extending for a distance of 75 metres Southern

LAWS OF TRINIDAD AND TOBAGO

254

Chap. 48:50 *Motor Vehicles and Road Traffic*

[Subsidiary]

Miscellaneous Roads (Unilateral Parking) Order

COUNTY OF NARIVA—Continued

<i>Road</i>	<i>Side of Road</i>
2. Naparima-Mayaro Road from its junction with Rio Claro-Tabaquite Road and extending for a distance of 20 metres	Northern
3. Rio Claro-Tabaquite Road from a point 100 metres from its junction with Naparima-Mayaro Road and extending in a northerly direction for a distance of 150 metres	Eastern

PART D

COUNTY OF ST. ANDREW

<i>Road</i>	<i>Side of Road</i>
1. Ojoe Road from its junction with the Main Road at the Roundabout and extending in a northerly direction for a distance of 40 metres	Eastern
2. Cunapo Southern Road from its junction with Andre Street and extending in a northerly direction for a distance of 70 metres	Western
3. Foster Local Road from its junction with Toco Road and extending in a northerly direction for a distance of 75 metres	Western
4. Old Railway Station Road East (Exit).	Western

PART E

COUNTY OF ST. DAVID

Nil

PART F

COUNTY OF ST. GEORGE EAST

<i>Road</i>	<i>Side of Road</i>
1. Riverside Road between the Eastern Main Road and Gordon Street	Eastern
2. Eastern Main Road between Orange Grove Road and Dinsley Junction	Southern
3. Hollis Avenue between John Shaw Avenue and King Street, Arima	Northern

LAWS OF TRINIDAD AND TOBAGO

Motor Vehicles and Road Traffic

Chap. 48:50

255

Miscellaneous Roads (Unilateral Parking) Order

[Subsidiary]

PART G

COUNTY OF ST. GEORGE WEST

<i>Road</i>	<i>Side of Road</i>
1. St. Ann's Road between Lady Young Road and Simon Valley Road, St. Ann's	Eastern
2. Norfolk Street, Belmont in the City of Port-of-Spain between Jerningham Avenue and Erthig Road	Eastern
3. Queen's Park East, Port-of-Spain from St. Ann's Roundabout to the northern end of Charlotte Street	Eastern
4. Park Avenue, Queen's Park East in the City of Port-of-Spain	Southern
5. Queen's Park West between Queen's Park East and Frederick Street, Port-of-Spain	Southern
6. Queen's Park West from a point on that side of the road opposite to and central of Chancery Lane and continuing in a westerly direction for a distance of 30 metres in the City of Port-of-Spain	Northern
7. Keate Street between Queen's Park East and Frederick Street in the City of Port-of-Spain	Northern
8. Park Street between St. Vincent Street and Edward Street, Port-of-Spain	Southern
9. Park Street between Richmond Street and Edward Street, Port-of-Spain	Northern
10. Duke Street between Charlotte Street and George Street in the City of Port-of-Spain	Northern
11. Knox Street in the City of Port-of-Spain from Frederick Street for a distance of 20 metres	Northern
12. Prince Street between Nelson Street and Duncan Street, Port-of-Spain	Southern
13. London Street in the City of Port-of-Spain	Southern
13A. Independence Square between Wrightson Road and Edward Street	Southern
14. Independence Square North between St. Vincent Street and Frederick Street in the City of Port-of-Spain	Northern

LAWS OF TRINIDAD AND TOBAGO

256

Chap. 48:50 *Motor Vehicles and Road Traffic*

[Subsidiary]

Miscellaneous Roads (Unilateral Parking) Order

COUNTY OF ST. GEORGE WEST—Continued

<i>Road</i>	<i>Side of Road</i>
15. Independence Square North between Henry Street and George Street in the City of Port-of-Spain	Northern
16. Piccadilly Street between Prince Street and Park Street in the City of Port-of-Spain	Western
17. Nelson Street between Independence Square North and South Quay in the City of Port-of-Spain	Western
18. Charlotte Street, Port-of-Spain from the junction of Queen's Park East to the junction of New Street	Eastern
19. Frederick Street between Queen's Park West and Keate Street, Port-of-Spain	Eastern
20. Chacon Street between Independence Square South and South Quay, Port-of-Spain	Western
21. St. Vincent Street, from Electric Pole No. 23 extending South for a distance of 20 metres in the City of Port-of-Spain	Western
22. St. Vincent Street, from the exit of the Red House Driveway (Southern Exit) South to Hart Street	Eastern
23. St. Vincent Street between Treasury Street and Independence Square North in the City of Port-of-Spain	Western
24. Edward Street between Park Street and Tragarete Road in the City of Port-of-Spain	Eastern
25. Edward Street, Port-of-Spain, between Independence Square South and Wrightson Road	Western
26. Tragarete Road between Edward Street and St. Vincent Street, Port-of-Spain	Northern
27. Flament Street, Port-of-Spain, between Park Street and Wrightson Road	Western
28. Beetham Highway Southern Carriageway between the Dry River and St. Vincent Street in the City of Port-of-Spain	Southern between 6.00 a.m. and 6.00 p.m.
29. Wrightson Road between signs on the Southern Carriageway from a point 10 metres East of the Entrance to the Flour Mill in the City of Port-of-Spain	Southern

LAWS OF TRINIDAD AND TOBAGO

Motor Vehicles and Road Traffic

Chap. 48:50

257

Miscellaneous Roads (Unilateral Parking) Order

[Subsidiary]

<i>Road</i>	<i>Side of Road</i>
30. Maraval Road between Prada Street and St. Clair Avenue	Western
31. Mucurapo Road, Port-of-Spain, between Warren and Ethel Streets	Southern
31A. Rust Street	Southern
31B. Alcazar Street	Southern
31C. Marli Street	Southern
32. Gaston Johnson Street in the City of Port-of-Spain	Eastern
33. Panka Street, St. James between Nizam Street and Ethel Street	Southern
34. First Avenue, San Juan, in the Ward of St. Ann's between the Eastern Main Road and Second Street	Western
35. Colda Tinda Avenue, San Juan	Western Monday to Friday
36. First Street, San Juan, in the Ward of St. Ann's between Saddle Road and First Avenue	Southern
37. First Street, San Juan, in the Ward of St. Ann's from a point 140 metres North of Second Street to Saddle Road	Southern
38. Maracas Bay in the Ward of St. Ann's	Northern
39. Keate Street between Frederick Street and Pembroke Street, in the City of Port-of-Spain	Southern
40. Fitz Blackman Drive, in the City of Port-of-Spain	Western

PART H

COUNTY OF ST. PATRICK

<i>Road</i>	<i>Side of Road</i>
1. Penal Rock Road opposite the Taxi and Omnibus Stands for a distance of 35 metres in Penal	Eastern
2. Clarke Road, Penal, between Siparia Road and Penal Rock Road	Eastern
3. School Road, Point Fortin between Mainsfield Road and Guapo-Cap-de-Ville Road	Southern

LAWS OF TRINIDAD AND TOBAGO

258

Chap. 48:50

Motor Vehicles and Road Traffic

[Subsidiary]

Miscellaneous Roads (Unilateral Parking) Order

PART I

TOBAGO

<i>Road</i>	<i>Side of Road</i>
1. Milford Road from its junction with Wilson Road to a point 115 metres West, Scarborough	Southern between 6.00 a.m. and 6.00 p.m.
2. Milford Road from the western end of the Licensing Office to Government Farm Road, Scarborough	Northern
3. Milford Road from the junction of Orange Hill Road to Wilson Road, Scarborough	Northern
4. Ross Street from Piggott Street to Jerningham Street, Scarborough	Southern
5. Main Street from Fort Street to Castries Street, Scarborough	Southern
6. Piggott Street from Burnett Street to Jerningham Street, Scarborough	Northern
7. Piggott Street between Robinson and Bacolet Streets, Scarborough	Northern
8. Carrington Street between Castries and Exit Streets from Customs Area, Scarborough	Southern
9. Carrington Street from Wilson Road to a point 5 metres from the Truck Stand, Scarborough	Southern
10. Carrington Street from its junction with Castries Street and extending in a westerly direction to the Bailey Bridge, Scarborough	Northern
11. Jerningham Street from Ross Street to Piggott Street, Scarborough	Eastern
12. Entry Street to Customs Area, Scarborough	Eastern

PART J

COUNTY OF VICTORIA

<i>Road</i>	<i>Side of Road</i>
1. King's Wharf (Eastern side of bus terminus) from a point 10 metres South of St.Vincent Street to Queen Street, San Fernando	Eastern

LAWS OF TRINIDAD AND TOBAGO

Motor Vehicles and Road Traffic

Chap. 48:50

259

Miscellaneous Roads (Unilateral Parking) Order

[Subsidiary]

<i>Road</i>	<i>Side of Road</i>
2. Queen Street, San Fernando	Northern
3. Harris Promenade North, San Fernando	Northern
4. Harris Promenade South, San Fernando	Southern
5. Library Street, San Fernando	Southern
6. Court Street from Harris Street to Lewis Street, San Fernando	Northern
7. Mucurapo Street from Cemetery Street to Lord Street, San Fernando	Eastern
8. Prince Alfred Street from Cemetery Street to Keate Street, San Fernando	Eastern
9. Ciperio Street from Ciperio Bridge to Scott Street, San Fernando	Western
10. Park Street from Ciperio Street to Todd Street, San Fernando	Northern
11. Buen Intento Road from the northern end of the Taxi Stand to Water Lane, Princes Town	Eastern
12. Railway Road, Princes Town	Eastern
13. Tramline Street, Princes Town	Northern
14. Naparima-Mayaro Road between King Street and Aldana Street, Princes Town	Western
15. Naparima-Mayaro Road from Railway Road to Buen Intento Road, Princes Town	Northern
16. Naparima-Mayaro Road between Railway Road and Lothians Road, Princes Town	Southern

LAWS OF TRINIDAD AND TOBAGO

260 **Chap. 48:50** *Motor Vehicles and Road Traffic*

[Subsidiary]

208/1979.
[220/1980
75/1985].

**MISCELLANEOUS ROADS (UNILATERAL
ALTERNATE PARKING) ORDER**

made under section 65

Citation. **1.** This Order may be cited as the Miscellaneous Roads (Unilateral Alternate Parking) Order.

Parking of vehicle. **2.** No person shall cause or permit a vehicle to be or to remain parked on any road described in the first column of the Schedule on the side of the road mentioned in the second column of the said Schedule on the days of the week and where applicable at the times mentioned in the third column of the said Schedule.

Parking of bicycle. **3.** No person shall cause or permit any bicycle to be or to remain parked on any of the roads mentioned in the Schedule, otherwise than the opposite side of the road to that on which other vehicles are required by the provisions of this Order, and when so parked shall be in line and not less than one metre the one from the other.

Offence. **4.** Any person who contravenes any of the provisions of this Order is liable on summary conviction to a fine of five hundred dollars or to imprisonment for three months.

SCHEDULE

PART A

COUNTY OF CARONI

<i>Road</i>	<i>Side of Road</i>	<i>Day of Week and Time where Applicable</i>
1. Southern Main Road, Chaguanas between Longdenville Junction and Chaguanas Flyover	Northern	Tuesday, Thursday, Saturday
	Southern	Monday, Wednesday, Friday
2. That portion of Southern Main Road, Couva which lies between Isaac Junction and Carli Bay Road	Northern	Tuesday, Thursday, Saturday
	Southern	Sunday, Monday, Wednesday, Friday

LAWS OF TRINIDAD AND TOBAGO

Motor Vehicles and Road Traffic

Chap. 48:50

261

Miscellaneous Roads (Unilateral Alternate Parking) Order

[Subsidiary]

<i>Road</i>	<i>Side of Road</i>	<i>Day of Week and Time where Applicable</i>
3. That portion of the Southern Main Road, Couva which lies between the 35-kilometre post and Isaac Junction	Eastern	Tuesday, Thursday, Saturday
4. That portion of the Southern Main Road, Couva which lies between the Carli Bay Road and Railway Station Road, California	Western	Sunday, Monday, Wednesday, Friday

PART B

COUNTY OF MAYARO

Nil

PART C

COUNTY OF NARIVA

Nil

PART D

COUNTY OF ST. ANDREW

<i>Road</i>	<i>Side of Road</i>	<i>Day of Week and Time where Applicable</i>
1. Eastern Main Road, Sangre Grande, not including—		
(i) that portion of the Eastern Main Road from its junction with Toco Road at the Roundabout and extending in a southerly direction for a distance of 185 metres;	Northern	Sunday, Tuesday, Thursday, Saturday
(ii) that portion of the Eastern Main Road from its junction with Ojoe Road at the Roundabout and extending in a westerly direction to the junction of Picton Road.	Southern	Monday, Wednesday, Friday
2. Toco Road, Sangre Grande, not including the Western portion between Henderson Street and the Eastern Main Road.		

PART E

COUNTY OF ST. DAVID

Nil

LAWS OF TRINIDAD AND TOBAGO

262

Chap. 48:50 *Motor Vehicles and Road Traffic*

[Subsidiary]

Miscellaneous Roads (Unilateral Alternate Parking) Order

PART F

COUNTY OF ST. GEORGE EAST

<i>Road</i>	<i>Side of Road</i>	<i>Day of Week and Time where Applicable</i>
1. That portion of Abercromby Street, St. Joseph in the County of St. George which lies between the Eastern Main Road and Riverside Road	} Eastern } Western	Tuesday, Thursday, Saturday Sunday, Monday, Wednesday, Friday
2. Southern Main Road, Curepe in the Ward of St. Ann's	} Eastern } Western	Tuesday, Thursday, Saturday Monday, Wednesday, Friday
3. Tunapuna Road, Tunapuna	} Eastern } Western	Tuesday, Thursday, Saturday Sunday, Monday, Wednesday, Friday
4. That portion of Sorzano Street in the Borough of Arima which lies between Prince Street and St. Joseph Street	} Northern } Southern	Monday, Wednesday, Friday Tuesday, Thursday, Saturday
5. That portion of Broadway in the Borough of Arima which lies between Queen Street and Prince Street	} Northern } Southern	Monday, Wednesday, Friday Tuesday, Thursday, Saturday
6. That portion of Guanapo Street in the Borough of Arima which lies between Prince Street and Temple Street	} Northern } Southern	Monday, Wednesday, Friday Tuesday, Thursday, Saturday
7. That portion of Green Street in the Borough of Arima which lies between Cocorite Street and St. Joseph Street	} Northern } Southern	Monday, Wednesday, Friday Tuesday, Thursday, Saturday
8. That portion of Farfan Street in the Borough of Arima which lies between Cocorite Street and St. Joseph Street	} Northern } Southern	Monday, Wednesday, Friday Tuesday, Thursday, Saturday
9. That portion of Hollis Avenue between King Street and Pro-Queen Street	} Northern } Southern	Monday, Wednesday, Friday Tuesday, Thursday, Saturday
10. That portion of Devenish Street in the Borough of Arima which lies between Cocorite Street and Green Street	} Northern } Southern	Monday, Wednesday, Friday Tuesday, Thursday, Saturday
11. That portion of John Shaw Avenue in the Borough of Arima which lies between Providence Circular Road and Queen Mary Avenue	} Northern } Southern	Monday, Wednesday, Friday Tuesday, Thursday, Saturday

LAWS OF TRINIDAD AND TOBAGO

Motor Vehicles and Road Traffic

Chap. 48:50

263

Miscellaneous Roads (Unilateral Alternate Parking) Order

[Subsidiary]

<i>Road</i>	<i>Side of Road</i>	<i>Day of Week and Time where Applicable</i>
12. That portion of St. Joseph Street in the Borough of Arima which lies between Hollis Avenue and Sanchez Street		
13. That portion of Woodford Street in the Borough of Arima which lies between Hollis Avenue and Sorzano Street		
14. That portion of Prince Street in the Borough of Arima which lies between Broadway and Longden Street		
15. That portion of Queen Street in the Borough of Arima which lies between Sanchez Street and Hollis Avenue		
16. That portion of Pro-Queen Street in the Borough of Arima which lies between Hollis Avenue and Railway Road	Eastern	Monday, Wednesday, Friday
17. That portion of Cocorite Street in the Borough of Arima which lies between Green Street and Devenish Street	Western	Tuesday, Thursday, Saturday
18. That portion of Railway Road in the Borough of Arima which lies between Robinson Circular Road and Pro-Queen Street		
19. That portion of O'Meara Road in the Borough of Arima which lies between Trinidad Government Railway Crossing and Churchill-Roosevelt Highway		
20. That portion of Industry Lane in the Borough of Arima which lies between Hollis Avenue and Rawle Circular		
21. That portion of King Street in the Borough of Arima which lies between Hollis Avenue and Sanchez Street		

LAWS OF TRINIDAD AND TOBAGO

PART G

COUNTY OF ST. GEORGE WEST

<i>Road</i>	<i>Side of Road</i>	<i>Day of Week and Time where Applicable</i>
1. Cascade Road situated in the Ward of St. Ann's which commences at the intersection of the St. Ann's Road with the Cascade Road and continues in a north-easterly direction to a point where the said Cascade Road meets Coblenz Avenue	Northern	Tuesday, Thursday and Saturday, between 8.00 a.m. and 8.00 p.m. Public Holidays not included
	Southern	Monday, Wednesday and Friday, between 8.00 a.m. and 8.00 p.m. Public Holidays not included
2. Cascade Road, from its intersection with Coblenz Avenue to Spring Bank Avenue	Northern	Tuesday, Thursday, Saturday
	Southern	Monday, Wednesday, Friday
3. Cascade Road, from Walker Avenue to Knightsbridge	Northern	Tuesday, Thursday, Saturday
4. Coblenz Avenue between St. Ann's Road and Cascade Road	Southern	Monday, Wednesday, Friday
5. Saddle Road in the Ward of St. Ann's between the St. Clair Roundabout and its junction with Long Circular Road, Port-of-Spain	Eastern	Tuesday, Thursday and Saturday
	Western	Sunday, Monday, Wednesday and Friday
6. Prada Street, St. Clair	Northern	Tuesday, Thursday and Saturday
7. (<i>Deleted by LN 75/1985</i>)		
8. Pelham Street, Belmont	Eastern	Sunday, Monday, Wednesday and Friday
	Western	Tuesday, Thursday and Saturday
9. Braithwaite Lane, Belmont	Eastern	Tuesday, Thursday and Saturday
	Western	Sunday, Monday, Wednesday and Friday
10. Willis Street, Belmont	Northern	Tuesday, Thursday and Saturday
	Southern	Sunday, Monday, Wednesday and Friday

LAWS OF TRINIDAD AND TOBAGO

Motor Vehicles and Road Traffic

Chap. 48:50

265

Miscellaneous Roads (Unilateral Alternate Parking) Order

[Subsidiary]

<i>Road</i>	<i>Side of Road</i>	<i>Day of Week and Time where Applicable</i>
11. Winton Lane, Belmont	Eastern Western	Tuesday, Thursday and Saturday Sunday, Monday, Wednesday and Friday
12. Agard Lane, Belmont	} Northern } Southern	Tuesday, Thursday and Saturday Sunday, Monday, Wednesday and Friday
13. Altorf Street, Belmont		
14. St. Francois Valley Road, Belmont between Belmont Valley Road and Belmont Circular Road		
15. Erthig Road between Norfolk Street and Belmont Circular Road	Northern Southern	Tuesday, Thursday Saturday Monday, Wednesday, Friday
16. Jerningham Avenue between Queen's Park East and Belmont Circular Road	Northern Southern	Tuesday, Thursday, Saturday Monday, Wednesday, Friday
17. Norfolk Street commencing at the western intersection with Belmont Circular Road and ending at its northern intersection with the said Belmont Circular Road	} Eastern } Western	Sunday, Tuesday, Thursday, Saturday Monday, Wednesday, Friday
18. Belmont Circular Road between Belle Eau Road and Belmont Valley Road		
19. Belmont Circular Road between McShine Terrace and Norfolk Street		
20. Belmont Circular Road between Norfolk Street and Belle Eau Road	} Northern } Southern	Tuesday, Thursday, Saturday Monday, Wednesday, Friday
21. Belmont Circular Road between Belmont Valley Road and Queen's Park East		
22. Belmont Circular Road between Charlotte Street and McShine Terrace		
23. McShine Terrace, Belmont	Northern Southern	Tuesday, Thursday, Saturday Sunday, Monday, Wednesday, Friday
24. Observatory Street between Charlotte Street and Belmont Circular Road	Eastern Western	Sunday, Tuesday, Thursday, Saturday Monday, Wednesday, Friday

LAWS OF TRINIDAD AND TOBAGO

266

Chap. 48:50 *Motor Vehicles and Road Traffic*

[Subsidiary]

Miscellaneous Roads (Unilateral Alternate Parking) Order

COUNTY OF ST. GEORGE WEST—Continued

<i>Road</i>	<i>Side of Road</i>	<i>Day of Week and Time where Applicable</i>
25. Chancery Lane between Keate Street and Gordon Street	Eastern	Monday, Wednesday, Friday
	Western	Tuesday, Thursday, Saturday
26. Gordon Street between Charlotte and Frederick Streets	Northern	Sunday, Monday, Wednesday, Friday,
	Southern	Tuesday, Thursday, Saturday
27. Gordon Street between Pembroke Street and Dundonald Street	Northern	Monday, Wednesday, Friday
	Southern	Tuesday, Thursday, Saturday
28. New Street, Port-of-Spain between Dundonald Street and Victoria Avenue	Northern	Monday, Wednesday, Friday
	Southern	Tuesday, Thursday, Saturday
29. Park Street, Port-of-Spain between St. Vincent and Charlotte Streets	Northern	Tuesday, Thursday, Saturday
	Southern	Monday, Wednesday, Friday
30. Duke Street between George Street and Piccadilly Street	Northern	Tuesday, Thursday, Saturday
	Southern	Monday, Wednesday, Friday
31. Duke Street, Port-of-Spain— (i) between Charlotte Street and Richmond Street; (ii) between Melbourne Street and Wrightson Road.	Northern	Tuesday, Thursday, Saturday
	Southern	Monday, Wednesday, Friday
32. Prince Street between Frederick Street and Nelson Street	Northern	Tuesday, Thursday, Saturday
33. Prince Street between Duncan Street and Piccadilly Street, Port-of-Spain	Northern	Tuesday, Thursday, Saturday
	Southern	Monday, Wednesday, Friday
34. Sackville Street between St. Vincent Street and Wrightson Road	Northern	Tuesday, Thursday, Saturday
35. Queen Street between Richmond Street and Chacon Street	Northern	Tuesday, Thursday, Saturday
36. Queen Street between Frederick Street and Piccadilly Street	Northern	Tuesday, Thursday, Saturday
37. St. Joseph Road between the Eastern Main Road and Piccadilly Street	Northern	Tuesday, Thursday, Saturday
	Southern	Sunday, Monday, Wednesday, Friday
38. Old St. Joseph Road	Northern	Sunday, Monday, Wednesday, Friday
	Southern	Tuesday, Thursday, Saturday

LAWS OF TRINIDAD AND TOBAGO

Motor Vehicles and Road Traffic

Chap. 48:50

Miscellaneous Roads (Unilateral Alternate Parking) Order

[Subsidiary]

<i>Road</i>	<i>Side of Road</i>	<i>Day of Week and Time where Applicable</i>
39. Piccadilly Street in the City of Port-of-Spain between South Quay and St. Joseph Road	Eastern Western	Tuesday, Thursday, Saturday Sunday, Monday, Wednesday, Friday
40. Duncan Street between Prince Street and South Quay	Eastern Western	Sunday, Tuesday, Thursday, Saturday Monday, Wednesday, Friday
41. Nelson Street between Duke Street and South Quay		
42. George Street between Duke Street and South Quay		
43. Charlotte Street between Gordon Street and Observatory Street		
44. Charlotte Street between Park Street and South Quay		
45. Henry Street between Gordon Street and South Quay		
46. Frederick Street between Keate Street and Gordon Street	Eastern Western	Sunday, Tuesday, Thursday, Saturday Monday, Wednesday, Friday
47. Frederick Street between New Street and Independence Square North		
48. Chacon Street between Queen Street and Independence Square South		
49. Pembroke Street between Keate Street and Gordon Street		
50. Pembroke Street between New Street and Knox Street		
51. Abercromby Street between Keate Street and South Quay		
52. St. Vincent Street between Gordon Street and Treasury Street, Port-of-Spain, but not including those portions of St. Vincent Street appearing under Head G of the First Schedule to the Miscellaneous Roads (Unilateral Parking) Order		
53. St. Vincent Street between Independence Square North and Independence Square South, Port-of-Spain		

LAWS OF TRINIDAD AND TOBAGO

268

Chap. 48:50 *Motor Vehicles and Road Traffic*

[Subsidiary]

Miscellaneous Roads (Unilateral Alternate Parking) Order

COUNTY OF ST. GEORGE WEST—Continued

<i>Road</i>	<i>Side of Road</i>	<i>Day of Week and Time where Applicable</i>
54. Edward Street in the City of Port-of-Spain between Tragarete Road and Gordon Street	Eastern Western	Tuesday, Thursday, Saturday Sunday, Monday, Wednesday, Friday
55. Edward Street between Park Street and Independence Square North but not including those portions of Edward Street appearing under Head G of the First Schedule to the Road Traffic (Prohibited Parking) Order	} Eastern } Western	Sunday, Tuesday, Thursday, Saturday Monday, Wednesday, Friday
56. Dundonald Street 	Eastern Western	Tuesday, Thursday, Saturday Sunday, Monday, Wednesday, Friday
57. Richmond Street between Tragarete Road and Fraser Street	} Eastern } Western	Monday, Wednesday, Friday Sunday, Tuesday, Thursday, Saturday
58. Richmond Street between Park Street and Independence Square South		
59. Francis Street between Sackville Street and Charles Street		
60. Melbourne Street, Port-of-Spain ...	Eastern Western	Tuesday, Thursday, Saturday Monday, Wednesday, Friday
61. Charles Street, Port-of-Spain ...	Northern Southern	Tuesday, Thursday, Saturday Sunday, Monday, Wednesday, Friday
62. Borde Street between Tragarete Road and New Street	} Eastern } Western	Tuesday, Thursday, Saturday Sunday, Monday, Wednesday, Friday
63. Colville Street, from Wrightson Road to Tragarete Road		
64. Methuen Street	} Northern	Tuesday, Thursday, Saturday
65. McDonald Street	} Southern	Monday, Wednesday, Friday

LAWS OF TRINIDAD AND TOBAGO

Motor Vehicles and Road Traffic

Chap. 48:50

Miscellaneous Roads (Unilateral Alternate Parking) Order

[Subsidiary]

<i>Road</i>	<i>Side of Road</i>	<i>Day of Week and Time where Applicable</i>
66. French Street between Tragarete Road and Ariapita Avenue	Eastern	Tuesday, Thursday, Saturday
67. French Street, from Wrightson Road to Ariapita Avenue		
68. Maraval Road between Tragarete Road and Queen's Park West		
69. Cornelio Street, from Wrightson Road to Tragarete Road	Western	Sunday, Monday, Wednesday, Friday
70. Tragarete Road between Damian Street and Edward Street	Northern	Monday, Wednesday, Friday
	Southern	Sunday, Tuesday, Thursday, Saturday
71. Luis Street between Roberts Street and Ariapita Avenue	Eastern	Tuesday, Thursday, Saturday
	Western	Sunday, Monday, Wednesday, Friday
72. Pole Carew Street, Woodbrook, between Warren Street and Tragarete Road	Eastern	Monday, Wednesday, Friday
	Western	Sunday, Tuesday, Thursday, Saturday
73. That portion of Warren Street in the City of Port-of-Spain which lies between Rosalino Street and Belle-Smythe Street	Northern	Tuesday, Thursday, Saturday
74. Warner Street between Cipriani Boulevard and Maraval Road	Southern	Sunday, Monday, Wednesday, Friday
75. Picton Street between Tragarete Road and Queen's Park West	Eastern	Tuesday, Thursday, Saturday
	Western	Sunday, Monday, Wednesday, Friday
76. Ana Street between Warren Street and Wrightson Road	Eastern	Sunday, Tuesday, Thursday, Saturday
	Western	Monday, Wednesday, Friday
77. Petra Street between Warren Street and Wrightson Road	Eastern	Sunday, Tuesday, Thursday, Saturday
	Western	Monday, Wednesday, Friday
78. Damian Street in the City of Port-of-Spain between Tragarete Road and Warren Street	Eastern	Tuesday, Thursday, Saturday
	Western	Sunday, Monday, Wednesday, Friday

LAWS OF TRINIDAD AND TOBAGO

270

Chap. 48:50 *Motor Vehicles and Road Traffic*

[Subsidiary]

Miscellaneous Roads (Unilateral Alternate Parking) Order

COUNTY OF ST. GEORGE WEST—Continued

<i>Road</i>	<i>Side of Road</i>	<i>Day of Week and Time where Applicable</i>
79. Mucurapo Road between Ethel Street and Western Main Road	Northern	Sunday, Tuesday, Thursday, Saturday
	Southern	Monday, Wednesday, Friday
80. Lucknow Street between Hyderabad Street and Western Main Road in the City of Port-of-Spain	Northern	Tuesday, Thursday, Saturday
	Southern	Monday, Wednesday, Friday
81. Long Circular Road in the City of Port-of-Spain between Saddle Road and Dibe Road, Port-of-Spain	Northern	Tuesday, Thursday, Saturday
	Southern	Sunday, Monday, Wednesday, Friday
82. Bengal Street, St. James between the Western Main Road and Delhi Street	Eastern	Sunday, Tuesday, Thursday, Saturday between 6.00 a.m. and 6.00 p.m.
	Western	Monday, Wednesday, Friday, between 6.00 a.m. and 6.00 p.m.
82A. Woodford Street, between Tragarete Road and Queen's Park West	Eastern	Tuesday, Thursday, Saturday
82B. Agra Street, St. James, between Western Main Road and Patna Street	Western	Sunday, Monday, Wednesday, Friday
83. Henry Pierre Street in the City of Port-of-Spain	Eastern	Tuesday, Thursday, Saturday
84. Nizam Street, St. James in the City of Port-of-Spain		
85. Ethel Street, St. James 		
86. Pujadas Street, St. James 	Northern	Tuesday, Thursday, Saturday
	Southern	Sunday, Monday, Wednesday, Friday
87. Luckput Street 	Eastern	Tuesday, Thursday, Saturday
88. Coronation Street 	Western	Sunday, Monday, Wednesday, Friday
89. Western Main Road, St. James in the City of Port-of-Spain	Northern	Monday, Wednesday, Friday
	Southern	Sunday, Tuesday, Thursday, Saturday

LAWS OF TRINIDAD AND TOBAGO

Motor Vehicles and Road Traffic

Chap. 48:50

271

Miscellaneous Roads (Unilateral Alternate Parking) Order

[Subsidiary]

<i>Road</i>	<i>Side of Road</i>	<i>Day of Week and Time where Applicable</i>		
90. Western Main Road, Carenage between Jellicoe Street and Haig Street	Northern	Tuesday, Thursday, Saturday		
	Southern	Sunday, Monday, Wednesday, Friday		
91. First Street, San Juan between the Eastern Main Road and Second Street	} Northern	Sunday, Tuesday, Thursday, Saturday		
92. First Street, San Juan between First Avenue and Seventh Avenue				
93. Second Street, San Juan between First Street and Saddle Road			} Southern	Monday, Wednesday, Friday
94. Second Street, San Juan between First Avenue and Seventh Avenue				
95. Saddle Road, San Juan between Mission Road and the 4-kilometre post	Eastern	Tuesday, Thursday, Saturday		
	Western	Sunday, Monday, Wednesday, Friday		
96. Back Chain Street	Northern	Tuesday, Thursday, Saturday		
	Southern	Monday, Wednesday, Friday		
97. El Socorro Road from Back Chain Street to Churchill-Roosevelt Highway	Eastern	Sunday, Tuesday, Thursday, Saturday		
	Western	Monday, Wednesday, Friday		

LAWS OF TRINIDAD AND TOBAGO

272

Chap. 48:50 *Motor Vehicles and Road Traffic*

[Subsidiary]

Miscellaneous Roads (Unilateral Alternate Parking) Order

PART H

COUNTY OF ST. PATRICK

<i>Road</i>	<i>Side of Road</i>	<i>Day of Week and Time where Applicable</i>
1. That portion of Coora Road, Siparia, in the County of St. Patrick which lies between High Street and Mary Street	Eastern	Tuesday, Thursday, Saturday
	Western	Sunday, Monday, Wednesday, Friday
2. That portion of High Street, Siparia, in the County of St. Patrick which lies between Allies and La Pastora Streets	Northern	Tuesday, Thursday, Saturday
	Southern	Sunday, Monday, Wednesday, Friday
3. That portion of the Fyzabad-Guapo Road in the County of St. Patrick commencing at the junction of the said Fyzabad-Guapo Road and Oropouche Road continuing in a southerly direction and ending at the 4-kilometre mark on the said Fyzabad-Guapo Road	Eastern	Sunday, Tuesday, Thursday, Saturday
	Western	Monday, Wednesday, Friday
4. Point Fortin Main Road, between the A.B.C. Roundabout and Shell Trinidad Limited Main gate	Northern	Sunday, Tuesday, Thursday, Saturday
	Southern	Monday, Wednesday, Friday
5. That portion of the Point Fortin Main Road which lies between Frisco Junction and the A.B.C. Junction	Eastern	Tuesday, Thursday, Saturday
6. That portion of Guapo-Cap-de-Ville Road in the County of St. Patrick which lies between the A.B.C. Junction and the Point Ligoure Junction	Western	Sunday, Monday, Wednesday, Friday
7. Techier Road, Point Fortin	Northern	Monday, Wednesday, Friday
	Southern	Tuesday, Thursday, Saturday

PART I

TOBAGO

Nil

LAWS OF TRINIDAD AND TOBAGO

Motor Vehicles and Road Traffic

Chap. 48:50

273

Miscellaneous Roads (Unilateral Alternate Parking) Order

[Subsidiary]

PART J

COUNTY OF VICTORIA

<i>Road</i>	<i>Side of Road</i>	<i>Day of Week and Time where Applicable</i>
1. Guaracara-Tabaquite Road from a point 45 metres East of the Southern Main Road to Battoo Avenue	Northern	Sunday, Tuesday, Thursday, Saturday
	Southern	Monday, Wednesday, Friday
2. Southern Main Road, Marabella between the Guaracara River and the Marabella Roundabout	Eastern	Sunday, Tuesday, Thursday, Saturday
	Western	Monday, Wednesday, Friday
3. Royal Road	Eastern	Sunday, Tuesday, Thursday, Saturday
	Western	Monday, Wednesday, Friday
4. Coffee Street from a point 45 metres East of Johnstone Street to Navet Road	Northern	Sunday, Tuesday, Thursday, Saturday
	Southern	Monday, Wednesday, Friday
5. Naparima-Mayaro Road from Circular Road to the Mon Repos Roundabout	Northern	Sunday, Tuesday, Thursday, Saturday
	Southern	Monday, Wednesday, Friday
6. Ciperio Street from Park Street to 34 metres South of Coffee Street	Eastern	Sunday, Tuesday, Thursday, Saturday
	Western	Monday, Wednesday, Friday
7. Rushworth Street from Independence Avenue to Bertrand Street	Northern	Sunday, Tuesday, Thursday, Saturday
	Southern	Monday, Wednesday, Friday
8. Prince Alfred Street from Keate Street to Rushworth Street	Eastern	Sunday, Tuesday, Thursday, Saturday
	Western	Monday, Wednesday, Friday
9. High Street, San Fernando but not including that portion appearing under Part "J" of the Schedule to the Public Stands (Taxis) Parking Order	Northern	Sunday, Tuesday, Thursday, Saturday
	Southern	Monday, Wednesday, Friday
10. Prince of Wales Street from Coffee Street to Rushworth Street	Eastern	Sunday, Tuesday, Thursday, Saturday
	Western	Monday, Wednesday, Friday

LAWS OF TRINIDAD AND TOBAGO

274

Chap. 48:50 *Motor Vehicles and Road Traffic*

[Subsidiary]

Miscellaneous Roads (Unilateral Alternate Parking) Order

COUNTY OF VICTORIA—Continued

<i>Road</i>	<i>Side of Road</i>	<i>Day of Week and Time where Applicable</i>
11. Chacon Street	} Northern } Southern	Sunday, Tuesday, Thursday, Saturday Monday, Wednesday, Friday
12. Carib Street from La Coulee Street to Coffee Street		
13. Johnstone Street		
14. San Fernando Street 	Northern	Tuesday, Thursday, Saturday
	Southern	Sunday, Monday, Wednesday, Friday
15. St. Vincent Street	} Northern } Southern	Sunday, Tuesday, Thursday, Saturday Monday, Wednesday, Friday
16. Keate Street from Prince Alfred Street to Prince of Wales Street and from Gransaul Street to Independence Avenue		
17. Circular Road from Pointe-a-Pierre Road to a point 90 metres West of London Street		
18. Penitence Street from Harris Promenade (North) to High Street	Eastern	Sunday, Tuesday, Thursday, Saturday
	Western	Monday, Wednesday, Friday
19. Pointe-a-Pierre Road from the Southern Main Road to a point 30 metres North of Mount Moriah Road	Eastern	Sunday, Tuesday, Thursday, Saturday
	Western	Monday, Wednesday, Friday
20. Pointe-a-Pierre Road from a point 30 metres North of Chacon Street to Short Street		
21. Quenca Street from San Fernando Street to its junction with Vistabella Road	Eastern	Sunday, Tuesday, Thursday, Saturday
	Western	Monday, Wednesday, Friday
22. Vistabella Road		
23. St. James Street between Penitence Street and Pointe-a-Pierre Road	Northern	Sunday, Tuesday, Thursday, Saturday
	Southern	Monday, Wednesday, Friday

PRIVATE MOTOR CARS (PARKING PLACES) ORDER

ARRANGEMENT OF CLAUSES

CLAUSE

1. Citation.
2. Interpretation.
3. Parking for private motor car.
4. Parking in manner prescribed.
5. Parking in scheduled area.
6. Obstruction and traffic signs.
7. Offences.

SCHEDULE.

SCHEDULE

PART I

PORT-OF-SPAIN

1. The area bounded as follows:
NORTH—by Independence Square North.
SOUTH—by Independence Square South.
EAST—by George Street.
WEST—by Charlotte Street.
2. The area bounded as follows:
NORTH—by Independence Square North.
SOUTH—by Independence Square South.
EAST—by Charlotte Street.
WEST—by Henry Street.
3. *(Deleted by LN 151/1981).*
4. The area bounded as follows:
NORTH—by Independence Square North.
SOUTH—by Independence Square South.
EAST—by Abercromby Street.
WEST—by St. Vincent Street.
5. The area bounded as follows:
NORTH—by Independence Square North.
SOUTH—by Independence Square South.
EAST—by St. Vincent Street.
WEST—by Edward Street.
6. The area bounded as follows:
NORTH—by the building occupied by Government Wireless Station.
SOUTH—by Wrightson Road.
EAST—by St. Vincent Street.
WEST—by the building occupied by the Planning and Housing Commission and by Edward Street.
7. Hart Street bounded as follows:
EAST—by Frederick Street.
WEST—by Abercromby Street.
8. The southern half of the parking lot situated at the corner of Naparima-Mayaro Road and Guayaguayare Road (opposite the Mayaro Market).

LAWS OF TRINIDAD AND TOBAGO

278

Chap. 48:50

Motor Vehicles and Road Traffic

[Subsidiary]

Private Motor Cars (Parking Places) Order

PART II

TOBAGO

1. Scarborough Wharf—on the western side of Entry Street to Customs Area facing South, alongside the northern and southern Customs Warehouses—three cars respectively.
 2. Exit Street from Customs Area—Western side, from a point two metres away from the junction with Carrington Street and extending in a southerly direction for a distance of fifteen metres—three private cars facing North.
 3. Exit Street from Customs Area—Western side, from a point one metre South of the Wharf Gate and extending in a southerly direction for a distance of twenty metres—eight private cars facing north-east.
 4. Exit Street from Customs Area—Eastern side, in front of the Customs Building—six private cars facing North.
 5. Exit Street from Customs Area—in front of the Post Office Building—five private cars facing North.
 6. Jerningham Street—in front of the Administration Building—ten private cars facing north-west.
 7. Bacolet Street—Western side at the rear of the Administration Building—ten private cars facing south-east.
-

PUBLIC STANDS (TAXIS) PARKING ORDER

ARRANGEMENT OF CLAUSES

CLAUSE

1. Citation.
2. Parking places for taxis.
3. Parking in prescribed manner.
4. Taxis shall stand in line.
5. Taxis standing for hire.
6. Public stands.
7. Offence.

SCHEDULE.

LAWS OF TRINIDAD AND TOBAGO

280

Chap. 48:50

Motor Vehicles and Road Traffic

[Subsidiary]

*212/1979.

PUBLIC STANDS (TAXIS) PARKING ORDER

made under section 65

Citation.

1. This Order may be cited as the Public Stands (Taxis) Parking Order.

Parking places for taxis.

2. The Public Stands described in the Schedule are hereby appointed as parking places for taxis.

Parking in prescribed manner.

3. Any taxi while waiting at the parking places described in the Schedule shall be parked in the prescribed manner only, and at night when so parked shall not be required to carry any lighted lamps.

Taxis shall stand in line.

4. The taxis shall stand in line commencing five metres from the near kerb of any intersecting road unless otherwise provided and not less than one metre nor more than one metre apart from each other: Provided that where taxis are required or permitted to stand alongside each other they shall so stand not less than three hundred millimetres apart, and not less than one metre between the lines.

Taxis standing for hire.

5. (1) Taxis standing for hire in stands shall leave such stands for the purpose of answering calls according to their priority of position in such stands and not otherwise.

(2) On the departure of any taxi standing for hire in any such stands the taxi next in rear thereto shall move forward and occupy the vacant place, and in like manner other taxis in rear shall move forward in the line and occupy the vacant spaces immediately in front of them.

Public stands.

6. No vehicles other than taxis may park in Public Stands appointed for taxis.

Offence.

7. Any person who contravenes any of the provisions of this Order is liable on summary conviction to a fine of five hundred dollars or to imprisonment for three months.

*This Order has been amended by the following: 220/1980; 149/1983; 164/1984; 75/1985; 97/1985; 183/1986.

SCHEDULE

PART A

COUNTY OF CARONI

Taxi Stands—Chaguanas

1. Chaguanas Main Road—Northern side from a point seventy metres East of Endeavour Road and extending in an easterly direction for a distance of fifty-two metres—nine taxis facing East.

2. Chaguanas Main Road—Southern side from a point ten metres of the Old Southern Main Road and extending in an easterly direction for a distance of one hundred and twenty metres—seventeen taxis facing West.

3. Old Southern Main Road—Eastern side from a point ten metres South of Chaguanas Main Road and extending in a southerly direction for a distance of one hundred and ten metres—ten taxis facing South.

4. Old Southern Main Road—Eastern side from a point ten metres South of Eleanor Street and extending in a southerly direction for a distance of fifty metres—eight taxis facing South.

5. St. Yves Street—Western side from a point twenty metres North of the Chaguanas Main Road and extending in a northerly direction for a distance of forty metres—six taxis facing North.

6. Noel Street—on the western side, North of Gran Couva Road, from a point nine metres extending northwards—twelve taxis facing South.

Taxi Stands—Carapichaima

Waterloo Road, St. Mary's Junction—Northern side from a point ten metres West of the entrance to the Gas Station and extending in a westerly direction for a distance of forty metres (Church entrance shall be free of obstruction) —six taxis facing West.

PART B

COUNTY OF MAYARO

Taxi Stands—Mayaro

The northern half of the parking lot situated at the corner of Naparima-Mayaro Road and Guayaguayare Road (opposite the Mayaro Market)—eleven taxis parked within lines painted or marked on the surface of the said parking lot.

LAWS OF TRINIDAD AND TOBAGO

282

Chap. 48:50

Motor Vehicles and Road Traffic

[Subsidiary]

Public Stands (Taxis) Parking Order

PART C

COUNTY OF NARIVA

Taxi Stands—Rio Claro

1. Naparima-Mayaro Road—Southern side from a point fifty metres East of the junction of Guayaguayare Road and extending in an easterly direction for a distance of forty-five metres—eighteen taxis facing North.
2. Naparima-Mayaro Road—From a point forty metres East of Cunapo South Road, along the northern side of Railway Road—ten taxis facing East.

PART D

COUNTY OF ST. ANDREW

Taxi Stand—Sangre Grande

1. Railway Station Road Exit—Eastern side—eight taxis facing south-west.
2. Old Railway Station Road—Northern side near wall of Public Transport Service Corporation Administration Building—ten taxis facing South.
3. Cunapo Southern Main Road—Eastern side from a point ten metres North of Andre Street and extending in a northerly direction for a distance of fifty metres—eight taxis facing South.
4. Foster Local Road—Eastern side from a point ten metres North of Toco Main Road and extending in a northerly direction for a distance of seventy-three metres—sixteen taxis facing South.
5. Ojoe Road—from a point ten metres North of Eastern Main Road and extending in a northerly direction for a distance of twenty-five metres—four taxis parked as follows:
 - between 6.00 a.m. and 6.00 p.m. daily, on eastern side facing South.
 - between 6.00 p.m. and 6.00 a.m. daily, on western side facing North.

PART E

COUNTY OF ST. DAVID

Nil

LAWS OF TRINIDAD AND TOBAGO

Motor Vehicles and Road Traffic

Chap. 48:50

283

Public Stands (Taxis) Parking Order

[Subsidiary]

PART F

COUNTY OF ST. GEORGE EAST

Taxi Stands—Curepe

Evans Street—From a point thirty metres from the corner of Old Southern Main Road and Evans Street.

Taxi Stands—Arouca

Golden Grove Road—Eastern side from a point twenty-three metres South of the Eastern Main Road extending in a southerly direction—ten taxis facing South.

Taxi Stands—Arima

1. Broadway—Northern side between Queen Street (Dial) and Prince Street—fourteen taxis facing East.

2. North side of Broadway from a point ten metres East of Woodford Street to a point indicated by studs fifteen metres West of Queen Street—fifteen taxis facing East.

3. Pro-Queen Street—Western side between Hollis Avenue and deVerteuil Street—fifteen taxis facing North.

4. West side of Pro-Queen Street from a point thirty metres South of Hollis Street and extending in a southerly direction for sixty metres—ten taxis facing North.

5. Queen Street—Western side, from a point nine metres South of the corner of Farfan Street—twelve taxis facing South.

PART G

COUNTY OF ST. GEORGE WEST

Taxi Stands—Port-of-Spain

1. Queen's Park West—On North side, opposite to the front of Queen's Park Hotel—twenty taxis facing East.

2. Queen's Park West—On South side in front of the Princes Building between the East entrance and West entrance of drive excluding entrance to central path—twenty-two taxis facing West.

LAWS OF TRINIDAD AND TOBAGO

284

Chap. 48:50

Motor Vehicles and Road Traffic

[Subsidiary]

Public Stands (Taxis) Parking Order

3. Green Corner—Southern side of Tragarete Road from a point three metres West of St. Vincent Street and extending in a westerly direction for a distance of eighty-five metres—fifteen taxis facing East.

4. Park Street—Northern side from a point ten metres East of Edward Street and extending in an easterly direction to a point ten metres West of St. Vincent Street—eight taxis facing West.

5. Duke Street—Southern side from a point ten metres West of George Street to a point ten metres East of Charlotte Street—ten taxis facing West.

6. At the corner of Piccadilly Street and Laventille Road.

7. Independence Square (North)—Southern side from George Street to Charlotte Street—nine taxis facing East.

8. Independence Square (North)—Southern side between Henry Street and Charlotte Street—twelve taxis facing East.

9. Independence Square (North)—Southern side from St. Vincent Street to Broadway—thirty-one taxis facing East.

10. Independence Square (North)—Southern side from Edward Street to St. Vincent Street—eight taxis facing East.

11. Independence Square (South)—Northern side from Duncan Street to Nelson Street—twelve taxis facing West.

12. Independence Square (South)—Northern side from George Street to Charlotte Street—seven taxis facing West.

13. Independence Square (South)—Northern side from Broadway to Chacon Street—ten taxis facing West.

14. Independence Square (South)—Northern side from Henry Street to Broadway—twenty-eight taxis facing South.

15. Broadway—On East side close to kerb from Independence Square North to Independence Square South—ten taxis facing West.

16. Broadway—On West side close to kerb from Independence Square North to Independence Square South—twelve taxis facing East.

LAWS OF TRINIDAD AND TOBAGO

Motor Vehicles and Road Traffic

Chap. 48:50

285

Public Stands (Taxis) Parking Order

[Subsidiary]

17. Dock Road—On North side and close to kerb from a point twenty-five metres West of No. 2 Gate, King's Wharf and extending in a westerly direction—seven taxis facing South.

18. Queen Street—On the southern side, from a point nine metres East of Nelson Street—ten taxis facing West.

Taxi Stands—Morvant

Lady Young Road—Western side shoulder from a point thirty metres North of Morvant Junction and extending northerly for a distance of thirty-four metres. The width of the said Taxi Stand is to commence six metres West of the Lady Young Road and to extend for a distance of a further six metres West thereof—ten taxis facing north-east.

Taxi Stands—San Juan

1. Eastern Main Road—The south-east corner of the El Socorro Road junction—nine taxis facing south-west, the head of the rank being the taxi nearest the Post Office.

2. Second Street—Northern side from a point ten metres West of Saddle Road and extending in a westerly direction for twenty metres—three taxis facing East.

3. Second Street—Northern side from a point forty-five metres West of Saddle Road and extending in a westerly direction for sixty metres—nine taxis facing East.

4. Prizgar Road—Northern side from a point nine metres West of Saddle Road extending westward to a point nine metres East of Newalloville Extension Road—forty taxis facing East.

5. First Street—Northern side, from a point nine metres East of Saddle Road to a point one hundred metres farther East of the said road—twenty taxis facing West.

PART H

COUNTY OF ST. PATRICK

Taxi Stands—Penal

1. Siparia-Erin Road—Western side along the frontage of the Police Station—five taxis facing North.

2. Siparia-Erin Road—Western side from a point twelve metres South of Clarke Street and extending in a southerly direction for a distance of forty metres—six taxis facing North.

LAWS OF TRINIDAD AND TOBAGO

286

Chap. 48:50

Motor Vehicles and Road Traffic

[Subsidiary]

Public Stands (Taxis) Parking Order

3. Penal Rock Road—Southern side from a point twelve metres East of Siparia-Erin Road and extending in an easterly direction for a distance of twenty metres—eight taxis facing north-east.

Taxi Stands—Siparia

1. Eastern side of the parking ground adjoining the Post Office on the Siparia-Erin Road—four taxis facing South.

2. Coora Extension Road—Eastern side of Siparia-Erin Road—six taxis facing South in herring-bone fashion.

Taxi Stands—Fyzabad

South side of Fyzabad-Guapo Road from a point twenty metres West of the junction of Fyzabad Road and extending in a westerly direction for a distance of thirty metres—four taxis facing West.

Taxi Stands—Point Fortin

1. Mainfield Road—Northern side—eight taxis facing West.

2. Frisco Junction—On the eastern side of the triangular piece of land known as the Savannah and bounded by the Point Fortin Main Road on the North, Mainfield Road on the South and the connecting road on the East—ten taxis facing East.

3. Cap-de-Ville Junction—On the piece of prepared ground at North side of the junction and bounded by the Guapo-Cap-de-Ville Road on the north-eastern side and the Point Fortin Main Road on the south-western side—twelve taxis parked as indicated on the site.

PART I

TOBAGO

Taxi Stands—Tobago

1. Piggott Street—On the South side close to kerb from Jerningham Street to Burnett Street—six taxis facing West.

2. Ross Street—On the North side close to kerb from Jerningham Street to Burnett Street—six taxis facing East.

3. Jerningham Street—On the West side close to kerb from a point three metres North of Main Street to a point twenty-five metres North of Main Street—four taxis facing North.

4. Carrington Street—Southern side from a point three metres West of Exit Street from Customs Area and extending in a westerly direction for a distance of seventy metres—twenty-five taxis facing north-east.

PART J

COUNTY OF VICTORIA

Taxi Stands—San Fernando

1. Harris Promenade—Southern side of Harris Promenade (Road) from a point twenty metres West of Library Street and extending in a westerly direction for a distance of forty-five metres—nine taxis facing West.

2. Harris Promenade—Eastern end of Harris Promenade (Grounds) northern side from a point five metres West of Library Street and extending in a westerly direction for a distance of thirty metres—six taxis facing West.

3. High Street—Southern side from a point ten metres West of Harris Promenade and extending in a westerly direction for a distance of one hundred and twenty metres—twenty taxis facing East.

4. Library Street—Northern side from a point ten metres West of Mucurapo Street and extending in a westerly direction for a distance of forty metres—seven taxis facing West.

5. Lord Street—Northern side from a point ten metres West of Mucurapo Street and extending in a westerly direction for a distance of sixty metres—ten taxis facing East.

6. Keate Street—Northern side from a point twenty metres West of Prince Alfred Street, and extending in a westerly direction for a distance of ninety metres—fifteen taxis facing East.

7. Queen Street—Southern side from a point five metres East of Lady Hailes Avenue and extending in an easterly direction for a distance of sixty metres—twenty-five taxis facing North in herring-bone fashion.

8. Mucurapo Street—Western side from a point ten metres South of Lord Street, and extending in a southerly direction for a distance of forty-two metres—seven taxis facing South.

LAWS OF TRINIDAD AND TOBAGO

288

Chap. 48:50

Motor Vehicles and Road Traffic

[Subsidiary]

Public Stands (Taxis) Parking Order

Taxi Stands—Princes Town

1. Naparima-Mayaro Road—Southern side from a point ten metres West of Bonanza Street and extending in a westerly direction for a distance of forty-five metres—seven taxis facing West.
 2. Naparima-Mayaro Road—Southern side from a point seventy metres West of Bonanza Street and extending in a westerly direction for a distance of forty-five metres—seven taxis facing West.
 3. North side of the Naparima-Mayaro Road from a point fifteen metres East of Bonanza Street and extending in an easterly direction for a distance of twenty metres—three taxis facing East.
 4. The area at the intersection of Naparima-Mayaro Road and Buen Intento Road known as the Roundabout—On the southern side, thirteen taxis facing North and on the northern side, nine taxis facing South.
 5. Buen Intento Road—Eastern side from a point twenty metres North of Naparima-Mayaro Road and extending in a northerly direction for a distance of forty metres—six taxis facing South.
-

**PUBLIC STANDS (MOTOR OMNIBUSES)
PARKING ORDER**

213/1979.

made under section 65

1. This Order may be cited as the Public Stands (Motor Omnibuses) Parking Order. Citation.

2. The Public Stands described in the Schedule are hereby appointed as parking places for motor omnibuses. Parking places for motor omnibuses.

3. Any motor omnibus while waiting at the parking places described in the Schedule shall be parked in the prescribed manner only, and at night when so parked shall not be required to carry any lighted lamps. Parking in prescribed manner.

4. No vehicles other than motor omnibuses may park in Public Stands appointed for motor omnibuses. Public Stands.

5. Any person who contravenes any of the provisions of this Order is liable on summary conviction to a fine of five hundred dollars or to imprisonment for three months. Offence.

SCHEDULE

PART A

COUNTY OF CARONI

Nil

PART B

COUNTY OF MAYARO

Nil

PART C

COUNTY OF NARIVA

Motor Omnibus Stands—Rio Claro

On the South side of the Naparima-Mayaro Road, East of the Taxi Stand—three omnibuses facing West.

LAWS OF TRINIDAD AND TOBAGO

290

Chap. 48:50

Motor Vehicles and Road Traffic

[Subsidiary]

Public Stands (Motor Omnibuses) Parking Order

PART D

COUNTY OF ST. ANDREW

Motor Omnibus Stands—Sangre Grande

1. South side of Railway Station Road from a point ten metres East of the former Railway Station “In” Road—seven motor omnibuses facing East.
2. North side of Andre Street five metres from the Cunapo Southern Road—two omnibuses facing West.

PART E

COUNTY OF ST. DAVID

Nil

PART F

COUNTY OF ST. GEORGE EAST

Motor Omnibus Stands—Arima

1. North side of Broadway from a point twenty metres East of Queen Street and extending in an easterly direction for a distance of twenty metres—two omnibuses facing East.
2. North side of Broadway from a point seventy metres East of Queen Street and extending in an easterly direction for a distance of thirty metres—three omnibuses facing East.
3. South side of Broadway from a point twenty metres East of Queen Street and extending in an easterly direction for a distance of forty-five metres—five omnibuses facing West.

PART G

COUNTY OF ST. GEORGE WEST

Nil

LAWS OF TRINIDAD AND TOBAGO

Motor Vehicles and Road Traffic

Chap. 48:50

291

Public Stands (Motor Omnibuses) Parking Order

[Subsidiary]

PART H

COUNTY OF ST. PATRICK

Motor Omnibus Stands—Penal

West side of Siparia-Erin Road from the twelve-kilometre post and extending in a northerly direction for a distance of forty-five metres—five omnibuses facing North.

PART I

TOBAGO

Motor Omnibus Stands—Tobago

Carrington Street from a point one metre West of Exit Street from Customs Area, Scarborough, to the sea wall—eight omnibuses facing North.

PART J

COUNTY OF VICTORIA

1. The Eastern side of the triangle in Buen Intento Road—two omnibuses facing North.

2. Omnibuses entering Princes Town from the East shall park along the North side of the Naparima-Mayaro Road from a point one hundred metres East of the corner of the Naparima-Mayaro Road and Buen Intento Road to a point three metres East of the said corner—two omnibuses facing East.

LAWS OF TRINIDAD AND TOBAGO

292 **Chap. 48:50** *Motor Vehicles and Road Traffic*

[Subsidiary]

215/1979.

GOODS VEHICLES STANDS PARKING ORDER

made under section 65

- Citation. **1.** This Order may be cited as the Goods Vehicles Stands Parking Order.
- Goods vehicles stands. **2.** The goods vehicles stands described in the Schedule are hereby appointed as places where goods vehicles may be parked.
- Parking for goods vehicle. **3.** No person shall cause or permit any vehicle other than a goods vehicle to be or to remain parked in the Goods Vehicle Stands appearing in the Schedule.
- Offence. **4.** Any person who contravenes any of the provisions of this Order is liable on summary conviction to a fine of five hundred dollars or to imprisonment for three months.

SCHEDULE

Goods Vehicle Stands—Port-of-Spain

The northern side of that portion of South Quay between Charlotte Street and George Street.

Goods Vehicle Stands—Scarborough, Tobago

Milford Road, on the southern side, from a point ten metres West of Wilson Road and extending in a westerly direction for ninety metres. All goods vehicles facing north-east.

PARKING ON DUAL CARRIAGE-WAYS ORDER

216/1979.

made under section 65

1. This Order may be cited as the Parking on Dual Carriage-ways Order. Citation.

2. Subject to any law in force relating to the parking of vehicles, no person shall cause or permit any vehicle to be or to remain parked on any dual carriage-way except on the extreme left-hand side of the portion of such carriage-way along which any such vehicle is lawfully proceeding. Parking on dual carriage-way.

3. Any person who contravenes any of the provisions of this Order is liable on summary conviction to a fine of five hundred dollars or to imprisonment for three months. Offence.

LAWS OF TRINIDAD AND TOBAGO

294 **Chap. 48:50** *Motor Vehicles and Road Traffic*

[Subsidiary]

73/1966.

QUEEN'S PARK SAVANNAH PARKING ORDER

made under section 65

Citation. **1.** This Order may be cited as the Queen's Park Savannah Parking Order.

Parking. **2.** (1) Subject to subclause (2) no person shall park or cause or permit any vehicle to be or to remain parked on that side of any of the roads abutting the Queen's Park Savannah which is further away from the said Savannah.

(2) Subclause (1) does not apply to that portion of the road designated as Queen's Park West which lies between the eastern entrance and the western entrance of the Princes Building and which is commonly known as the Princes Building Taxi Stand.

Offence. **3.** Any person who contravenes any of the provisions of clause 2(1) is liable on summary conviction to a fine of five hundred dollars or to imprisonment for three months.

**INDEPENDENCE SQUARE
(PARKING OF VEHICLES) ORDER**

220/1979.

made under section 65

1. This Order may be cited as the Independence Square Citation.
(Parking of Vehicles) Order.

2. (1) No person shall cause or permit any vehicle to be or Parking.
to remain parked on that portion of Independence Square South
between George Street and a point twenty-five metres
East of Broadway

(2) Subject to subclause (3) no person shall cause or
permit a vehicle to stand on that portion of Independence Square
South mentioned in subclause (1) in order that the vehicle may be
loaded or unloaded or that passengers may enter or leave
the vehicle.

(3) A person may cause or permit a goods vehicle to stand
on that portion of Independence Square South mentioned in
subclause (1) in order that the vehicle may be loaded or unloaded.

3. Any person who contravenes any of the provisions of this Offence.
Order is liable on summary conviction to a fine of five hundred
dollars or to imprisonment for three months.

LAWS OF TRINIDAD AND TOBAGO

296 **Chap. 48:50** *Motor Vehicles and Road Traffic*

[Subsidiary]

219/1979. **SOUTH QUAY (PARKING OF VEHICLES) ORDER**
made under section 65

Citation. **1.** This Order may be cited as the South Quay (Parking of Vehicles) Order.

Parking in the First Schedule. **2.** No person shall cause or permit any vehicle of a class or description specified in the first column of the First Schedule to be or to remain parked on the portions of South Quay in the City of Port-of-Spain between St. Vincent Street and Broadway and between Henry Street and Charlotte Street, save as in the manner prescribed therefor in the second column of the said Schedule.

Parking in the Second Schedule. **3.** No person shall cause or permit any vehicle to be or to remain parked on the portions of South Quay in Port-of-Spain, as specified in the Second Schedule.

Parking of heavy vehicles. **4.** No person shall cause or permit any vehicle in excess of 2,495 kilograms tare or a taxi to be or to remain parked on the southern side of South Quay between Henry Street and Charlotte Street.

Offence. **5.** Any person who contravenes any of the provisions of this Order is liable on summary conviction to a fine of five hundred dollars or to imprisonment for three months.

LAWS OF TRINIDAD AND TOBAGO

Motor Vehicles and Road Traffic

Chap. 48:50

297

South Quay (Parking of Vehicles) Order

[Subsidiary]

FIRST SCHEDULE

<i>Description of Type of Vehicle</i>	<i>Manner of Parking</i>
(a) Private motor cars not in excess of 2,495 kilograms tare	Within any two parallel white lines drawn in the centre of the road
(b) Any vehicle other than a vehicle specified in paragraph (a)	On the northern side of the road against the kerb.

SECOND SCHEDULE

1. That portion of South Quay in the City of Port-of-Spain which lies between Henry Street and Broadway.
2. The northern side of South Quay between George Street and Nelson Street.
3. The southern side of South Quay between George Street and Charlotte Street.

LAWS OF TRINIDAD AND TOBAGO

298 **Chap. 48:50** *Motor Vehicles and Road Traffic*

[Subsidiary]

218/1979. **BROADWAY (PARKING OF VEHICLES) ORDER**
made under section 65

Citation. **1.** This Order may be cited as the Broadway (Parking of Vehicles) Order.

Parking on Broadway. **2.** No person shall cause or permit any vehicle other than a vehicle mentioned in the first column of the Schedule to park or remain parked on the road known as Broadway in the City of Port-of-Spain between the hours of 6.00 a.m. and 6.00 p.m. on Mondays to Fridays inclusive save in the manner prescribed in the second column of the said Schedule.

Offence. **3.** Any person who contravenes any of the provisions of clause 2 is liable on summary conviction to a fine of five hundred dollars or to imprisonment for three months.

Application. **4.** This Order does not apply on Sundays, Saturdays and public holidays.

SCHEDULE

<i>Description or type of Vehicle</i>	<i>Manner of Parking</i>
Private motor cars... ..	Within the white lines drawn diagonally across the surface of the centre of the road.

LAWS OF TRINIDAD AND TOBAGO

Motor Vehicles and Road Traffic

Chap. 48:50

299

[Subsidiary]

ONE-WAY TRAFFIC ORDER

made under section 65

211/1979.
[220/1980
75/1985].

1. This Order may be cited as the One-Way Traffic Order. Citation.
2. No person shall drive any vehicle on any road specified in the Schedule to this Order otherwise than in the direction indicated in the said Schedule in respect of such road. Prohibition.
3. Any person who contravenes any of the provisions of this Order is liable on summary conviction to a fine of five hundred dollars or to imprisonment for three months. Offence.

SCHEDULE

PART A

COUNTY OF CARONI

A. In a westerly direction only

Edgar Street, Couva.

PART B

COUNTY OF MAYARO

A. In a westerly direction only

Pierreville Village Street in the Ward of Guayaguayare.

B. In an easterly direction only

1. Naparima-Mayaro Road in the Ward of Guayaguayare, from its intersection with Pierreville Village Street at its eastern end to the intersection with that Street at its western end.

LAWS OF TRINIDAD AND TOBAGO

300

Chap. 48:50

Motor Vehicles and Road Traffic

[Subsidiary]

One-Way Traffic Order

PART C

COUNTY OF NARIVA

Nil

PART D

COUNTY OF ST. ANDREW

A. In a northerly direction only

1. Andre Street from Cunapo Southern Road to Eastern Main Road, Sangre Grande, between 6.00 a.m. and 6.00 p.m. daily.
2. George Street from Mary Street to Eastern Main Road, Sangre Grande, between 6.00 a.m. and 6.00 p.m. daily.

B. In a southerly direction only

1. Ojoe Road from Brierley Street to Eastern Main Road, Sangre Grande, between 6.00 a.m. and 6.00 p.m. daily.
2. Cunapo Southern Road from Eastern Main Road to Mary Street, Sangre Grande, between 6.00 a.m. and 6.00 p.m. daily.

C. In an easterly direction only

1. Brierley Street from Riverside Extension Road to Foster Local Road, Sangre Grande, between 6.00 a.m. and 6.00 p.m. daily.

D. In a westerly direction only

1. Eastern Main Road, Sangre Grande, from its junction with Ojoe Road and Toco Road at the Roundabout on the East to the junction of Old Railway Road West, between 6.00 a.m. and 6.00 p.m. daily.
2. Mary Street from Cunapo Southern Road to George Street, Sangre Grande, between 6.00 a.m. and 6.00 p.m. daily.

E. In a northerly then easterly direction

1. Old Railway Road West—i.e., in a northerly direction from the Eastern Main Road, to the first bend, then in an easterly direction to Riverside Extension Road, between 6.00 a.m. and 6.00 p.m. daily.

LAWS OF TRINIDAD AND TOBAGO

Motor Vehicles and Road Traffic

Chap. 48:50

301

One-Way Traffic Order

[Subsidiary]

PART E

COUNTY OF ST. DAVID

A. In a northerly direction only

Paria Road in the Ward of Toco, between the Toco Depot and Church Street.

B. In a westerly direction only

Church Street in the Ward of Toco bounded on the East and West by the Paria Road.

PART F

COUNTY OF ST. GEORGE EAST

A. In a northerly direction only

1. St. Joseph Street between Hollis Avenue and Broadway, Arima.
2. Woodford Street between Hollis Avenue and Broadway, Arima.
3. Calcutta Street between Guanapo Street and Columbus Street, Arima

B. In a southerly direction only

Queen Street between Broadway and Hollis Avenue, Arima.

C. In an easterly direction only

Broadway between St. Joseph Street and Queen Street, Arima.

D. In a westerly direction only

Hollis Avenue between Queen Street and Woodford Street, Arima.

PART G

COUNTY OF ST. GEORGE WEST

A. In a northerly direction only

1. Hubert Lane between Gloster Lodge Road and Hermitage Road, Belmont.
2. Norfolk Street between Erthig Road and Belmont Circular Road, Belmont.
3. Duncan Street between Independence Square South and Prince Street in the City of Port-of-Spain.

LAWS OF TRINIDAD AND TOBAGO

302

Chap. 48:50

Motor Vehicles and Road Traffic

[Subsidiary]

One-Way Traffic Order

COUNTY OF ST. GEORGE WEST—*Continued*

4. George Street between South Quay and Duke Street in the City of Port-of-Spain.
5. Henry Street from South Quay to Gordon Street in the City of Port-of-Spain.
6. Frederick Street between Keate Street and Queen's Park West in the City of Port-of-Spain.
7. Pembroke Street between Knox Street and Keate Street in the City of Port-of-Spain.
8. Abercromby Street between South Quay and Keate Street in the City of Port-of-Spain.
9. Edward Street between Tragarete Road and Gordon Street in the City of Port-of-Spain.
10. Edward Street between Independence Square North and Tragarete Road in the City of Port-of-Spain.
11. Francis Street between Sackville Street and Charles Street in the City of Port-of-Spain.
12. Borde Street between Tragarete Road and New Street in the City of Port-of-Spain.
13. Belle-Smythe Street between Ariapita Avenue and Warren Street, Woodbrook.
14. Hamilton Holder Street and O'Connor Street between Wrightson Road and Ariapita Avenue, Woodbrook.
15. Gatacre Street, Woodbrook.
16. Alfredo Street, Woodbrook
17. Rosalino Street, Woodbrook.
18. Gallus Street, Woodbrook.
19. Petra Street between Warren Street and Ariapita Avenue, Woodbrook.
20. Damian Street between Warren Street and Kelly Kenny Street, Woodbrook.
21. Henry Pierre Street, Mucurapo.
22. Benares Street, St. James.

LAWS OF TRINIDAD AND TOBAGO

23. Coronation Street from Mucurapo Road to Western Main Road, St. James.
24. El Socorro Road, San Juan between the priority bus route and the Eastern Main Road.
25. Colda Tinda Avenue between Eastern Main Road and Second Street, San Juan.
26. First Street between Eastern Main Road and Saddle Road, San Juan.
27. Fitz Blackman Drive in the City of Port-of-Spain.

B. In a southerly direction only

1. Augustine Lane between Hermitage Road and Gloster Lodge Road, Belmont.
2. Belmont Circular Road between Belmont Valley Road and Erthig Road, Belmont.
3. Observatory Street between Belmont Circular Road and Charlotte Street.
4. Bath Street between Piccadilly Street and Siparia Hill in the City of Port-of-Spain.
5. Piccadilly Street between South Quay and Queen Street in the City of Port-of-Spain.
6. Nelson Street between South Quay and Duke Street in the City of Port-of-Spain.
7. Charlotte Street between Keate Street and Queen's Park West in the City of Port-of-Spain.
8. Charlotte Street between Park Street and South Quay in the City of Port-of-Spain.
9. Frederick Street between Keate Street and Independence Square North in the City of Port-of-Spain.
10. Chacon Street between Queen Street and Beetham Highway in the City of Port-of-Spain.
11. St. Vincent Street between Gordon Street and Independence Square North in the City of Port-of-Spain.
12. Dundonald Street between Queen's Park West and Tragarete Road in the City of Port-of-Spain.

LAWS OF TRINIDAD AND TOBAGO

304

Chap. 48:50

Motor Vehicles and Road Traffic

[Subsidiary]

One-Way Traffic Order

COUNTY OF ST. GEORGE WEST—Continued

13. Richmond Street between Fraser Street and Independence Square South in the City of Port-of-Spain.
 14. Scott-Bushe Street South Extension between Charles Street and the intersection of Wrightson Road and Sackville Street.
 15. Luis Street, Woodbrook.
 16. White Street, Woodbrook.
 17. Alberto Street, Woodbrook.
 18. Ana Street between Warren Street and Wrightson Road, Woodbrook.
 19. O'Connor Street between Warren Street and Ariapita Avenue, Woodbrook.
 20. De Verteuil Street and Dennis Mahabir Street between Ariapita Avenue and Wrightson Road.
 21. Gaston Johnson Street, Mucurapo.
 22. Lucknow Street, St. James.
 23. Luckput Street from Western Main Road, St. James to Mucurapo Road.
 24. Ethel Street, St. James between Pujadas Street and Mucurapo Road.
 25. Bridge Road, San Juan between Eastern Main Road and Maloney Street, between 3.00 p.m. and 6.00 p.m. daily.
 26. Broome Street, San Juan between Eastern Main Road and Maloney Street, between 3.00 p.m. and 6.00 p.m. daily.
 27. Savannah Street between Neverson Street and Bridge Road.
- C. *In an easterly direction only*
1. Meyler Street, Belmont.
 2. Belmont Circular Road from Charlotte Street to Observatory Street, Belmont.
 3. Queen's Park West between Frederick Street and Charlotte Street in the City of Port-of-Spain.
 4. New Street in the City of Port-of-Spain between Dundonald Street and Charlotte Street.
 5. Park Street between St. Vincent Street and Charlotte Street in the City of Port-of-Spain.

LAWS OF TRINIDAD AND TOBAGO

Motor Vehicles and Road Traffic

Chap. 48:50

305

One-Way Traffic Order

[Subsidiary]

6. Tragarete Road between Edward Street and St. Vincent Street in the City of Port-of-Spain.
7. Knox Street between Abercromby Street and Frederick Street in the City of Port-of-Spain.
8. Prince Street in the City of Port-of-Spain.
9. Sackville Street between Wrightson Road and Richmond Street in the City of Port-of-Spain.
10. Faure Street between George Street and Nelson Street in the City of Port-of-Spain.
11. Independence Square North between Wrightson Road and St. Joseph Road Bridge in the City of Port-of-Spain.
12. Warner Street from Maraval Road to Cipriani Boulevard in the City of Port-of-Spain.
13. McDonald Street, Woodbrook.
14. Warren Street between Belle-Smythe Street and Hamilton Street, Woodbrook.
15. Pujadas Street, St. James from Bay Road to Ethel Street.
16. Old St. Joseph Road, Laventille.
17. Second Street between First Avenue and First Street, San Juan.
18. Neverson Street, between Bridge Road and Savannah Street.

D. In a westerly direction only

1. Clifford Street, Belmont.
2. Erthig Road between Belmont Circular Road and Norfolk Street, Belmont.
3. Keate Street between Charlotte Street and Frederick Street in the City of Port-of-Spain.
4. Oxford Street between Observatory Street and Dundonald Street in the City of Port-of-Spain.
5. Fraser Street in the City of Port-of-Spain.
6. Kew Place between Longden Street and Park Street in the City of Port-of-Spain.
7. Park Street between St. Vincent Street and Edward Street in the City of Port-of-Spain.

LAWS OF TRINIDAD AND TOBAGO

306

Chap. 48:50

Motor Vehicles and Road Traffic

[Subsidiary]

One-Way Traffic Order

COUNTY OF ST. GEORGE WEST—*Continued*

8. Duke Street between Charlotte Street and Richmond Street in the City of Port-of-Spain.
9. Hart Street between Frederick Street and Abercromby Street in the City of Port-of-Spain.
10. Charles Street between Wrightson Road and Richmond Street in the City of Port-of-Spain.
11. London Street between Richmond Street and Wrightson Road in the City of Port-of-Spain.
12. Cockerton Street between George Street and Nelson Street in the City of Port-of-Spain.
13. Queen Street between Piccadilly Street and Richmond Street in the City of Port-of-Spain.
14. Treasury Street between St. Vincent Street and Edward Street in the City of Port-of-Spain.
15. Independence Square South between St. Joseph Road Bridge and Wrightson Road in the City of Port-of-Spain.
16. Marli Street, St. Clair from Queen's Park West to Maraval Road in the City of Port-of-Spain.
17. Methuen Street, Woodbrook.
18. Kelly Kenny Street, Woodbrook.
19. Hamilton Street, Woodbrook.
20. Avenue First, St. James from Ethel Street to Bay Road.
21. First Street between Second Street and First Avenue, San Juan.
22. First Street between Eastern Main Road and Saddle Road, San Juan.
23. Eastern Main Road from the intersection with the Old St. Joseph Road at its eastern end to the intersection with that road at its western end between the hours of 6.00 a.m. and 9.00 a.m. daily excluding Sundays and public holidays.
24. Ariapita Avenue, Woodbrook, between Belle-Smythe Street and Taylor Street.
25. Warren Street, Woodbrook, between Taylor Street and Belle-Smythe Street, between 6.00 a.m. and 9.00 a.m. and between 3.00 p.m. and 6.00 p.m. daily.

LAWS OF TRINIDAD AND TOBAGO

Motor Vehicles and Road Traffic

Chap. 48:50

307

One-Way Traffic Order

[Subsidiary]

26. Bridge Road between Savannah Street and Neverson Street.
27. Maloney Street between Eastern Main Road and Bushe Street.

PART H

COUNTY OF ST. PATRICK

A. In a southerly direction only

Clark Street, Penal between Siparia-Erin Road and Penal Rock Road.

B. In an easterly direction only

1. School Road, Point Fortin between Mainsfield Road and Guapo-Cap-de-Ville Road.
2. Mainsfield Road North between School Road and Point Fortin Main Road.

C. In a westerly direction only

Mainsfield Road South between School Road and Point Fortin Main Road.

PART I

TOBAGO

A. In a northerly direction only

1. Jerningham Street between Main Street and Piggott Street, Scarborough.
2. Exit Street from Customs Area, Scarborough.

B. In a southerly direction only

1. Burnett Street between Carrington and Main Streets, Scarborough.
2. Bacolet Street between Piggott and Main Streets, Scarborough.
3. Entry Street to Customs Area, Scarborough.

C. In a westerly direction only

1. Piggott Street between Bacolet and Robinson Streets, Scarborough.
2. Piggott Street between Jerningham and Burnett Streets, Scarborough.
3. Ross Street, Scarborough.

PART J

COUNTY OF VICTORIA

A. In a northerly direction only

1. Penitence Street between Harris Promenade and St. James Street, San Fernando.
2. Independence Avenue between Keate Street and Rushworth Street (Western Carriage-way), San Fernando.

B. In a southerly direction only

1. Mon Chagrin Street between St. James Street and High Street, San Fernando
2. Quenca Street between St. James Street and High Street, San Fernando.
3. Prince Alfred Street between Cemetery Street and Keate Street, San Fernando.
4. Mucurapo Street between Lord Street and Cemetery Street, San Fernando.
5. Mucurapo Street between Keate Street and Sutton Street, San Fernando.
6. Court Street between Harris Promenade South and Knox Street, San Fernando.
7. Independence Avenue between Keate Street and Rushworth Street (Eastern Carriage-way), San Fernando.

C. In a south-easterly direction only

1. Hollis Street, San Fernando.
2. Coffee Street between Mucurapo Street and Lord Street, San Fernando.

D. In an easterly direction only

1. San Fernando Street, San Fernando.
2. St. James Street between High Street and Quenca Street, San Fernando.
3. High Street between Chancery Lane and the Library Corner, San Fernando.

LAWS OF TRINIDAD AND TOBAGO

Motor Vehicles and Road Traffic

Chap. 48:50

309

One-Way Traffic Order

[Subsidiary]

4. Harris Promenade South, San Fernando.
5. Lord Street between Paradise Street and Mucurapo Street, San Fernando.
6. Carib Street, San Fernando.

In a westerly direction only

1. St. James Street between Pointe-a-Pierre Road and Quenca Street, San Fernando.
2. High Street between Chancery Lane and Queen Street, San Fernando.
3. Harris Promenade North, San Fernando.
4. Library Street, San Fernando.
5. Lord Street between Coffee Street and Mucurapo Street, San Fernando.
6. Johnstone Street, San Fernando.

LAWS OF TRINIDAD AND TOBAGO

310

Chap. 48:50

Motor Vehicles and Road Traffic

[Subsidiary]

EASTERN MAIN ROAD TRAFFIC ORDER

ARRANGEMENT OF CLAUSES

CLAUSE

1. Citation.
 2. Application.
 3. Division of Eastern Main Road
 4. Effect of Order.
 5. Hours and direction.
 6. Hours and direction.
 7. Use of middle lane.
 8. Parking on lanes.
 9. Offence.
-

EASTERN MAIN ROAD TRAFFIC ORDER

58/1976.

made under section 65

1. This Order may be cited as the Eastern Main Road Traffic Order. Citation.

2. This Order applies to that portion of the Eastern Main Road between Junction Box Crossing, St. Augustine and the Aranguez Road. Application.

3. For the purposes of this Order that portion of the Eastern Main Road referred to in clause 2 has been divided into three distinct lanes which are referred to in this Order as—
 - (a) the northern lane;
 - (b) the middle lane; and
 - (c) the southern lane.Division of Eastern Main Road.

4. This Order shall have effect from Mondays to Fridays inclusive, but only during the hours specified herein. Effect of Order.

5. Between the hours of 6.00 a.m. and 9.00 a.m. no person shall drive or cause any vehicle to be driven—
 - (a) on the northern lane otherwise than in an easterly direction; and
 - (b) on the southern and middle lanes otherwise than in a westerly direction.Hours and direction.

6. Between the hours of 3.00 p.m. and 6.00 p.m. no person shall drive or cause any vehicle to be driven—
 - (a) on the northern and middle lanes otherwise than in an easterly direction; and
 - (b) on the southern lane otherwise than in a westerly direction.Hours and direction.

7. Between the hours specified herein only the middle lane may be used at intersections for right-turning traffic. Use of middle lane.

LAWS OF TRINIDAD AND TOBAGO

312

Chap. 48:50

Motor Vehicles and Road Traffic

[Subsidiary]

Eastern Main Road Traffic Order

Parking on
lanes.

8. Notwithstanding any other written law to the contrary, between the hours specified herein no person shall park or cause or permit any vehicle to be parked or to remain on any of the lanes.

Offence.

9. A person who contravenes any of the provisions of this Order is liable on summary conviction to a fine of five hundred dollars or to imprisonment for three months.

LAWS OF TRINIDAD AND TOBAGO

Motor Vehicles and Road Traffic

Chap. 48:50

313

[Subsidiary]

BEETHAM HIGHWAY ORDER

60/1976.

made under section 65

1. This Order may be cited as the Beetham Highway Order. Citation.
 2. No person shall drive or cause any vehicle to be driven in an easterly direction on that portion of the northern carriageway of the Beetham Highway between Abattoir Road and Sea Lots Roundabout between the hours of 6.00 a.m. and 9.00 a.m. from Mondays to Fridays, inclusive. Direction in which vehicle to be driven.
 3. A person who contravenes any of the provisions of this Order is liable on summary conviction to a fine of five hundred dollars or to imprisonment for three months. Offence.
-

LAWS OF TRINIDAD AND TOBAGO

314 **Chap. 48:50** *Motor Vehicles and Road Traffic*

[Subsidiary]

56/1963.
[156/1985].

**RESTRICTION OF PARKING
(PUBLIC BUILDINGS) ORDER**

made under section 107(2)

Citation.

1. This Order may be cited as the Restriction of Parking (Public Buildings) Order.

Control of public buildings. Schedule.

2. For the purposes of this Order, the public buildings described in the first column of the Schedule shall be under the control of the respective public officers mentioned in the second column of the Schedule.

Public officers to grant permission to park. Schedule.

3. The public officers referred to in the second column of the Schedule are hereby authorised to grant permission to any person to park a vehicle in or on any grounds or open space adjoining or attached to the respective public buildings referred to in the first column of the Schedule.

56/1963.

SCHEDULE

All buildings occupied as offices by officers of the respective Ministries (except the Red House, the Old Fire Brigade Building and Knowsley)	The Permanent Secretaries of the appropriate Ministries	
The Red House and the Old Fire Brigade Building	The Permanent Secretary, Ministry of Legal Affairs	
Knowsley	The Permanent Secretary, Ministry of External Affairs	
The Magistrates' Courts, Port-of-Spain	The Chief Magistrate	
Magistrates' Courts (other than Port-of-Spain)	The Senior Magistrate of the District in which the Court is situated	
The Supreme Court, San Fernando	The Sub-Registrar and Deputy Marshal, San Fernando	
178/ 1970.	All buildings occupied for use as offices by the Comptroller of Customs and Excise and located at Port-of-Spain, San Fernando and Scarborough	The Comptroller of Customs and Excise
156/1985.	All buildings occupied for use by the Ministry of Agriculture, Lands and Food Production	The Permanent Secretary, Ministry of Agriculture, Lands and Food Production

**EXPERIMENTAL TRAFFIC
(PRIORITY BUS ROUTE) REGULATIONS**

181/1977.

made under section 44E

1. These Regulations may be cited as the Experimental Traffic (Priority Bus Route) Regulations. Citation.

2. In these Regulations— Interpretation.

“authorised vehicles” means public service vehicles of the Corporation, Police Service vehicles marked as such, Fire Service vehicles and ambulances and includes vehicles used for the repair or maintenance of the Priority Bus Route or of any services supplied by a public utility along the route;

“Committee” means the Priority Bus Route Management Committee;

“Corporation” means the Public Transport Service Corporation established by the Public Transport Service Corporation Act; Ch. 48:02.

“Priority Bus Route” means the special road so declared by the Minister of Works, Transport and Communications under section 3 of the Highways Act, by the Classification of Highways (Amendment) Order, commencing at the premises of the Corporation in San Juan and ending at the terminal of the Corporation in Port-of-Spain. Ch. 48:01. 180/1977.

3. (1) Subject to these Regulations, the Priority Bus Route is reserved for use exclusively by authorised vehicles and its use by any other vehicle or by pedestrians is prohibited. Reservation.

(2) Nothing in paragraph (1) shall be taken to prohibit the crossing of the Priority Bus Route by vehicles other than authorised vehicles or by pedestrians at intersections of the Priority Bus Route with any other roads.

(3) The drivers of authorised vehicles and all other persons using the Priority Bus Route shall conform with any directions and instructions concerning the use of the route given by the Committee.

LAWS OF TRINIDAD AND TOBAGO

316

Chap. 48:50 *Motor Vehicles and Road Traffic*

[Subsidiary]

Experimental Traffic (Priority Bus Route) Regulations

Offence.

4. (1) A person is guilty of an offence and liable to a fine of two hundred dollars and on a second or subsequent conviction to a fine of three hundred dollars who drives, parks, uses or otherwise places a vehicle not being an authorised vehicle on, or being a pedestrian uses, the Priority Bus Route contrary to regulation 3.

(2) A person who contravenes or fails to comply with any directions or instructions concerning the use of the Priority Bus Route given by the Committee under regulation 3(3) is liable to a fine of two hundred dollars.

PUBLIC STAND (MAXI-TAXI) PARKING ORDER

141/1981.

made under section 65

1. This Order may be cited as the Public Stand (Maxi-Taxi) Parking Order. Citation.

2. That area of Independence Square in Port-of-Spain which is surrounded on the North by Independence Square North, on the East by Chacon Street, on the South by Independence Square South, and on the West by Abercromby Street is hereby appointed as a parking place for maxi-taxis. Parking area.

3. Any maxi-taxi while waiting in the area described in paragraph 2 shall be parked, and shall leave and enter such area in the manner prescribed. Parking.

4. No vehicles other than maxi-taxis may park in the area herein appointed as a parking place. Prohibited parking.

5. Any person who contravenes this Order is liable on summary conviction to a fine of one hundred dollars or to imprisonment for three months. Offence.

**TRAFFIC RESTRICTION (QUEEN'S PARK
SAVANNAH RETICULATION) ORDER**

ARRANGEMENT OF CLAUSES

CLAUSE

1. Citation.
 2. Commencement.
 3. One-way traffic.
 4. No right turn.
 5. Parking prohibited.
 6. Parking prohibited.
 7. No parking on Saddle Road.
 8. Parking restricted.
 9. Removal and impounding of vehicles unlawfully parked.
-

**TRAFFIC RESTRICTION (QUEEN'S PARK
SAVANNAH RETICULATION) ORDER**

147/1981.

made under section 65

1. This Order may be cited as the Traffic Restriction (Queen's Park Savannah Reticulation) Order. Citation.

2. This Order shall come into operation at 6.00 a.m. on Wednesday, 21st October, 1981. Commencement.

3. All vehicular traffic shall proceed as indicated below — One-way traffic.
 - (a) Queen's Park East—in a southerly direction only;
 - (b) Queen's Park West—in a westerly direction only except in that area between Frederick Street and Charlotte Street where vehicles will be allowed to travel East along the southern side of Queen's Park West;
 - (c) Woodford Street, between Queen's Park West and Tragarete Road—in a southerly direction only;
 - (d) Picton Street, between Tragarete Road and Queen's Park West—in a northerly direction only;
 - (e) Maraval Road, between Queen's Royal College Roundabout and St. Clair Roundabout—in a northerly direction only;
 - (f) Circular Road—in an easterly direction only;
 - (g) Keate Street, between Frederick Street and Chancery Lane—in an easterly direction only;
 - (h) Lamy Street, between Saddle Road and Prada Street—in a southerly direction only;
 - (i) Newbold Street, between Scott Street and Saddle Road—in a southerly direction only;
 - (j) Prada Street, between Queen's Park Savannah and Newbold Street—in a westerly direction only;
 - (k) Fitzgerald Lane—in a westerly direction only;
 - (l) Dere Street—in a northerly direction only;

LAWS OF TRINIDAD AND TOBAGO

320

Chap. 48:50 *Motor Vehicles and Road Traffic*

[Subsidiary]

Traffic Restriction (Queen's Park Savannah Reticulation) Order

- (m) Melville Lane—in an easterly direction only;
- (n) Cummins Lane—in an easterly direction only.

No right turn.

4. No vehicular traffic on the undermentioned roads shall turn right on reaching the Queen's Park Savannah—

- (a) Lady Young Road;
- (b) Belmont Circular Road;
- (c) Cadiz Road;
- (d) Park Avenue;
- (e) Jerningham Avenue;
- (f) Chancery Lane;
- (g) Victoria Avenue;
- (h) Cipriani Boulevard;
- (i) Woodford Street;
- (j) Picton Street;
- (k) St. Clair Avenue;
- (l) Hayes Street;
- (m) Flood Street;
- (n) exit from Whitehall;
- (o) Serpentine Road;
- (p) Lady Chancellor Road;
- (q) entrance to Emperor Valley Zoo;
- (r) Visitors Entrance to President House;
- (s) exit from Princes Building Grounds.

Parking prohibited.

5. No person may park, or cause or permit any vehicle to be parked or to remain on any of the roads mentioned below—

- (a) Dere Street, between Cummins Lane and Queen's Park West, except for taxis plying for hire from the taxi stand on the western side;
- (b) eastern side of Queen's Park East;
- (c) Gordon Street, between Abercromby Street and St. Vincent Street;

LAWS OF TRINIDAD AND TOBAGO

Motor Vehicles and Road Traffic

Chap. 48:50

321

Traffic Restriction (Queen's Park Savannah Reticulation) Order

[Subsidiary]

- (d) Queen's Park East, between Jerningham Avenue and Queen's Park West;
- (e) Queen's Park East, between Belmont Circular Road and St. Ann's Roundabout.
- (f) Charlotte Street, between Queen's Park West and Keate Street;
- (g) Albion Street, between Stanmore Avenue and Dundonald Street;
- (h) Queen's Park West, between Victoria Avenue and Marli Street;
- (i) Queen's Park West, 90 metres West and 90 metres South of Casuals Club;
- (j) Queen's Park West, between Picton Street and Queen's Royal College Roundabout;
- (k) Maraval Road, between Queen's Royal College Roundabout and Hayes Street;
- (l) Maraval Road, between Serpentine Road and Prada Street;
- (m) southern side of Circular Road, between St. Clair Roundabout and the Visitor's Entrance to President House;
- (n) southern side of Circular Road, between the main Entrance to President House and St. Ann's Roundabout;
- (o) Victoria Avenue, between Cummins Lane and Queen's Park West, except for taxis plying for hire from the taxi stand on the eastern side only;
- (p) Victoria Avenue, between Queen's Park West and a distance of 60 metres South, except for taxis plying for hire from the Taxi Stand on the western side only.

6. While this Order is in force no person may park or cause or permit any vehicle to be parked or to remain — Parking prohibited.

- (a) on the western side of Queen's Park East, between Belmont Circular Road and Jerningham Avenue,

LAWS OF TRINIDAD AND TOBAGO

322

Chap. 48:50 *Motor Vehicles and Road Traffic*

[Subsidiary]

Traffic Restriction (Queen's Park Savannah Reticulation) Order

- between the hours of 7.00 a.m. and 9.00 a.m. and 3.00 p.m. and 5.00 p.m. from Mondays to Fridays;
- (b) on Maraval Road, between Hayes Street and Serpentine Road, between the hours of 7.00 a.m. and 9.00 a.m. and 3.00 p.m. and 5.00 p.m. from Mondays to Fridays.

No parking on Saddle Road.

7. While this Order is in force no person may park or cause or permit any vehicle to be parked on Saddle Road, between St. Clair Roundabout and Maraval River Bridge between the hours of 6.00 a.m. and 9.00 a.m. and 3.00 p.m. and 6.00 p.m. from Mondays to Fridays.

Parking restricted.

8. Parking is permitted on the undermentioned roads—

- (a) Albion Street, between Dundonald Street and Chancery Lane—on the northern side only;
- (b) Chancery Lane, between Keate Street and Gordon Street—on the western side only;
- (c) Frederick Street, between Keate Street and Queen's Park West—on the eastern side only;
- (d) Queen's Park West, between Queen's Park East and Cipriani Boulevard—on the northern side only;
- (e) Queen's Park West, between Cipriani Boulevard and Casuals Club—on the eastern side only;
- (f) Queen's Park West, between Casuals Club and Maraval Road—on the northern side only;
- (g) Maraval Road, between Queen's Park West and Circular Road—on the eastern side only;
- (h) Cummins Lane—on the northern side only.

Removal and impounding of vehicles unlawfully parked.

9. Without prejudice to any other liability incurred by the commission of a summary offence, vehicles found parked in contravention of this Order may be removed by the Police and impounded and otherwise dealt with in accordance with sections 108 and 109 of the Motor Vehicles and Road Traffic Act.

Ch. 48:50.

TRAFFIC RESTRICTION (SAN FERNANDO) ORDER

ARRANGEMENT OF CLAUSES

CLAUSE

1. Citation.
2. One-way traffic.
3. Parking prohibited
4. Parking restricted.
5. Two-way traffic.
6. No right turn.
7. Vehicular route.
8. Removal and impounding of vehicles unlawfully parked.

[Subsidiary]

152/1981.

TRAFFIC RESTRICTION (SAN FERNANDO) ORDER

made under section 65

Citation.

1. This Order may be cited as the Traffic Restriction (San Fernando) Order.

One-way traffic.

2. All vehicular traffic shall proceed as indicated below—

- (a) Coffee Street, from Royal Road and Navet Junction to Carib Street—in a westerly direction only;
- (b) Marryat Street, between Carib Street and Coffee Street—in a southerly direction only;
- (c) Upper Hillside Street between Carib Street and Coffee Street—in a northerly direction only;
- (d) Howard Lane between Carib Street and Coffee Street—in a southerly direction only;
- (e) Hobson Street—in an easterly direction only;
- (f) Kelshall Street—in an easterly direction only.

Parking prohibited.

3. No person may park or cause or permit any vehicle to be parked or to remain on any of the undermentioned roads—

- (a) High Street, between Hollis Street and Pointe-a-Pierre Road, except for taxis plying for hire in a Taxi Stand;
- (b) Prince of Wales Street, between Keate Street and Coffee Street;
- (c) Hollis Street, between High Street and Quenca Street;
- (d) Chancery Lane;
- (e) Pointe-a-Pierre Road, between High Street and the Naparima Girls High School Private Road, on the North near to the Texaco Gas Station;
- (f) Mon Chagrin Street, between High Street and St. James Street;

LAWS OF TRINIDAD AND TOBAGO

Motor Vehicles and Road Traffic

Chap. 48:50

325

Traffic Restriction (San Fernando) Order

[Subsidiary]

- (g) Penitence Street, between Harris Promenade and St. James Street;
- (h) St. Joseph Road, between London Street and the Bye-Pass.

4. Parking is permitted on the undermentioned roads— Parking restricted.
- (a) Ciperio Street, between Coffee Street and Rushworth Street—on the eastern side only;
 - (b) Mucurapo Street, between Keate Street and Sutton Street—on the eastern side only;
 - (c) Keate Street, between Mucurapo Street and Independence Avenue—
 - (i) on Mondays, Wednesdays and Fridays—on the northern side only;
 - (ii) on Tuesdays, Thursdays and Saturdays—on the southern side only;
 - (d) Court Street, between Independence Avenue and Harris Street—
 - (i) on Mondays, Wednesdays and Fridays—on the northern side only;
 - (ii) on Tuesdays, Thursdays and Saturdays—on the southern side only;
 - (e) Chacon Street, between King Street and Pointe-a-Pierre Road—
 - (i) on Mondays, Wednesdays and Fridays—on the northern side only;
 - (ii) on Tuesdays, Thursdays and Saturdays—on the southern side only;
 - (f) Ruth Avenue between Harris Street and Mucurapo Street—on the southern side only;
 - (g) Pointe-a-Pierre Road, between Cane Street and Mt. Moriah Road—
 - (i) on Tuesdays, Thursdays and Saturdays—on the western side only;
 - (ii) on Mondays, Wednesdays and Fridays—on the eastern side only;

LAWS OF TRINIDAD AND TOBAGO

326

Chap. 48:50

Motor Vehicles and Road Traffic

[Subsidiary]

Traffic Restriction (San Fernando) Order

Two-way traffic.

5. While this Order is in force, vehicular traffic may proceed on St. Joseph Road in both an easterly and westerly direction.

No right turn.

6. No vehicular traffic travelling along the undermentioned roads shall turn right on reaching the Bye-Pass—

(a) East along St. Joseph Road; and

(b) West along Forres Avenue.

Vehicular route.

7. While this Order is in operation, vehicular traffic proceeding South along the Bye-Pass may turn West into St. Joseph Road.

Removal and impounding of vehicles unlawfully parked.

8. Without prejudice to any other liability incurred by the commission of a summary offence, vehicles found parked in contravention of the foregoing provisions of this Order may be removed by the police and impounded and otherwise dealt with in accordance with sections 108 and 109 of the Motor Vehicles and Road Traffic Act.

Ch. 48:50.

NOTICE[242/1986
10/2003].**NOTICE OF EXEMPTION FROM REQUIREMENT
TO HOLD A DRIVER'S PERMIT ISSUED IN A
FOREIGN COUNTRY***made under section 56A(2)*

NOTICE is hereby given in accordance with section 56A(2) of the Motor Vehicles and Road Traffic Act that the holders of a valid driving permit issued in any of the countries listed in the Schedule shall, whilst such permit remains valid, be exempted for a period of three months commencing on the date of his arrival in Trinidad and Tobago, from the requirement to hold a driving permit issued under the Act.

SCHEDULE

Albania	Ecuador
Algeria	Egypt
Anguilla	Federal Republic of Germany
Antigua/Barbuda	Fiji
Argentina	Finland
Australia	France
Austria	Ghana
Bangladesh	Greece
Barbados	Grenada
Belgium	Guatemala
Belize	Guyana
Benin	Haiti
Botswana	Holy See
Brazil	Hungary
Bulgaria	Iceland
Canada	India
Central African Republic	Ireland
Chile	Israel
Congo	Italy
Cuba	Ivory Coast
Cyprus	Jamaica
*Czechoslovakia	Japan
Democratic Kampuchea	Jordan
Denmark	Lao People's Democratic Republic
Dominica	Lebanon
Dominican Republic	Lesotho

* Czechoslovakia is now divided between the Czech Republic and Slovakia.

LAWS OF TRINIDAD AND TOBAGO

328

Chap. 48:50

Motor Vehicles and Road Traffic

[Subsidiary]

*Notice of Exemption from Requirement to hold a Driver's Permit
issued in a Foreign Country*

SCHEDULE—Continued

Luxembourg	San Marino
Madagascar	Senegal
Malawi	Sierra Leone
Malaysia	Singapore
Mali	Spain
Malta	Sri Lanka
Monaco	St. Kitts/Nevis
Morocco	St. Lucia
Netherlands	St. Vincent and the Grenadines
New Zealand	Sweden
Niger	Switzerland
Nigeria	Syrian Arab Republic
Norway	Thailand
Papua New Guinea	Togo
Paraguay	Tunisia
People's Republic of China	Turkey
Peru	Uganda
Philippines	*Union of Soviet Socialist Republics
Poland	United Kingdom
Portugal	United States of America
Republic of Korea	Venezuela
Romania	†Yugoslavia
Rwanda	Zaire

* The Union of Soviet Socialist Republics is now divided between Armenia, Azerbaijan, Belarus, Estonia, Georgia, Kazakstan, Kyrgyzstan, Latvia, Lithuania, Moldova, Russia, Tajikistan, Turkmenistan, Ukraine and Uzbekistan.

† Yugoslavia is now divided between Bosnia-Herzegovina, Croatia, Macedonia, Slovenia and FR Yugoslavia.

TRAFFIC CONTROL REGULATIONS

ARRANGEMENT OF REGULATIONS

REGULATION

1. Citation.

PART I

PORT-OF-SPAIN

2. Maxi-taxi stand.
3. No entry to maxi-taxis
4. No entry to taxis.
5. Parking prohibited.
6. Parking.
7. Entry and exit from Richmond Street.
8. One-way traffic.

PART II

TUNAPUNA

9. One-way traffic.
10. Parking.
11. Parking prohibited.

PART III

CUREPE

12. No stopping or parking.

PART IV

ARIMA

13. One-way traffic.
14. No parking, stopping or waiting.
15. Parking prohibited.
16. Parking permitted.
17. No entry to maxi-taxis.

PART V

SANGRE GRANDE

18. One-way traffic.

LAWS OF TRINIDAD AND TOBAGO

330

Chap. 48:50

Motor Vehicles and Road Traffic

[Subsidiary]

Traffic Control Regulations

ARRANGEMENT OF REGULATIONS— *Continued*

REGULATIONS

PART VI

MARABELLA

19. One-way traffic.

PART VII

ST. MARGARET'S

20. Major road.

PART VIII

TOBAGO

21. Parking prohibited.
22. Two-way traffic.
23. Left turn.
24. Right turn.
25. Carrington Street.
26. No right turn.
27. Goods vehicles.
28. Road closure.

PART IX

PRINCES TOWN

29. Two-way traffic.
30. No right turn.
31. No left turn.
32. Maxi-taxi stand.

PART X

CHAGUARAMAS

33. Speed limit.

PART XI

SAN JUAN

34. One-way streets.

PART XII

GENERAL

35. Weight limits on main roads.
36. Removal and impounding of vehicles unlawfully parked.
-

TRAFFIC CONTROL REGULATIONS

90/1993.

made under section 100

1. These Regulations may be cited as the Traffic Control Regulations. Citation.

PART I

PORT-OF-SPAIN

2. Maxi-taxi drivers plying route one (Cocorite) may park in the area bounded by Abercromby Street, Chacon Street, Independence Square North and Independence Square South. Maxi-taxi stand.

3. Maxi-taxis are prohibited on— No entry to maxi-taxis.

- (a) Frederick Street, between Park Street and Independence Square North;
- (b) Charlotte Street, between Duke Street and Queen Street;
- (c) Queen Street, between Charlotte Street and Chacon Street;
- (d) Duke Street, between Henry Street and Pembroke Street;
- (e) Independence Square North, between Chacon Street and Nelson Street; and
- (f) Park Street, between St. Vincent Street and Charlotte Street.

4. Taxis shall not enter— No entry to taxis.

- (a) Henry Street, between Independence Square North and Queen Street;
- (b) Frederick Street, between Hart Street and Independence Square North; and
- (c) Queen Street, between Henry Street and Chacon Street.

5. Parking is prohibited on the following roads: Parking prohibited.

- (a) the northern side of Kew Place, between Philipps Street and Richmond Street;

LAWS OF TRINIDAD AND TOBAGO

332

Chap. 48:50

Motor Vehicles and Road Traffic

[Subsidiary]

Traffic Control Regulations

- (b) the northern side of Marli Street, between Woodford Street and Maraval Road;
- (c) Richmond Street, between Independence Square North and Independence Square South;
- (d) Rapsey Street, between Wainwright Street and Saddle Road;
- (e) the eastern side of Cipriani Boulevard, for a distance of forty metres North of Tragarete Road;
- (f) the southern side of Keate Street, between Chancery Lane and Abercromby Street;
- (g) the western side of Abercromby Street, between Gordon Street and Keate Street;
- (h) the eastern side of Victoria Avenue, between New Street and Tragarete Road; and
- (i) Colville Street, between Tragarete Road and Ariapita Avenue, between the hours of 7.00 a.m. and 5.00 p.m. on Mondays to Fridays.

Parking.

6. Motorists may park their vehicles on—

- (a) the southern side of Marli Street, between Woodford Street and Maraval Road except in the immediate vicinity of the Embassy of the Federal Republic of Germany as marked; and
- (b) the eastern side of Abercromby Street, between Keate Street and Gordon Street.

Entry and exit from Richmond Street.

7. Motorists may enter and exit Richmond Street, between Independence Square North and Independence Square South through the Independence Square North intersection.

One-way traffic.

8. Motorists shall proceed—

- (a) in an easterly direction on Roberts Street, between French Street and Colville Street;
- (b) in a westerly direction on Kitchener Street, between Colville Street and French Street;

- (c) in an easterly direction on Baden-Powell Street, between French Street and Colville Street;
- (d) in a westerly direction on Buller Street, between Colville Street and French Street; and
- (e) in a northerly direction on Stephens Road, Maraval.

PART II

TUNAPUNA

9. Motorists shall proceed—

One-way traffic.

- (a) in a westerly direction on Sapodilla Street, between St. Vincent Street and Bowen Street;
- (b) in a northerly direction on Bowen Street, between Sapodilla Street and Cornell Street; and
- (c) in a southerly direction on St. Vincent Street, between Francis Street and the Eastern Main Road.

10. Motorists may park on Pasea Main Road, between Bharrat Trace and Churchill-Roosevelt Highway on the eastern side on Mondays, Wednesdays and Fridays and on the western side on Tuesdays, Thursdays and Saturdays.

Parking.

11. Parking is prohibited on—

Parking prohibited.

- (a) Macoya Road, between Back Street and the Priority Bus Route; and
- (b) Bharrat Trace, between Pasea Main Road and Centenary Street.

PART III

CUREPE

12. Motorists shall not stop or park on the Southern Main Road, between Churchill-Roosevelt Highway and a point one hundred and twenty-five metres South of the Churchill-Roosevelt Highway.

No stopping or parking.

PART IV

ARIMA

One-way traffic.

13. Motorists shall proceed—

- (a) in a clockwise direction around the Princess Royal Park;
- (b) in a southerly direction on Pro-Queen Street, from Robinson Circular to Railway Road;
- (c) in a northerly direction on Railway Road, from the Priority Bus Route to Robinson Circular;
- (d) in a southerly direction on Industry Street, from Anglican Street to Hollis Avenue;
- (e) in a southerly direction on St. Joseph Street, from Sorzano Street to Hollis Avenue;
- (f) in a northerly direction on Woodford Street, from Hollis Avenue to Sorzano Street;
- (g) in a southerly direction on Queen Street, from Sorzano Street to Hollis Avenue;
- (h) in a westerly direction on Farfan Street, from Cocorite Street to St. Joseph Street;
- (i) in a westerly direction on Rose Street, between St. Joseph Street and King Street;
- (j) in an easterly direction on Green Street, between King Street and Cocorite Street;
- (k) in an easterly direction on Sorzano Street, between King Street and Prince Street;
- (l) in a southerly direction on Raglan Street;
- (m) in a northerly direction on Prince Street, from Broadway to Sorzano Street;
- (n) in an easterly direction on Devenish Street, from Queen Street to Cocorite Street;
- (o) in a westerly direction on De Verteuil Street, from Llanos Street to Pro-Queen Street; and
- (p) in a westerly direction on Quesnel Street, from Nelson Street to Pro-Queen Street.

14. Motorists shall not park, stop or wait on the following roads from 6.00 a.m. to 8.00 p.m. on Mondays to Fridays and from 6.00 a.m. to 1.00 p.m. on Saturdays:

No parking, stopping or waiting.

- (a) the western side of Queen Street, between Broadway and Devenish Street; and
- (b) the northern side of Hollis Avenue, between Pro-Queen Street and St. Joseph Street.

15. Except for taxi drivers operating from taxi stands, motorists shall not park on the following roads from 6.00 a.m. to 8.00 p.m. on Mondays to Fridays and from 6.00 a.m. to 1.00 p.m. on Saturdays:

Parking prohibited.

- (a) on Green Street, between Cocorite Street and Woodford Street;
- (b) on Cocorite Street, between Broadway and Quesnel Street;
- (c) on Sorzano Street, between St. Joseph Street and Queen Street;
- (d) on Farfan Street, between Woodford Street and Cocorite Street;
- (e) on Pro-Queen Street, between Devenish Street and Quesnel Street;
- (f) on Broadway, between St. Joseph Street and Woodford Street;
- (g) on Prince Street, between Sorzano Street and Broadway;
- (h) on Lopez Street, between Industry Street and King Street on the northern side; and
- (i) on the eastern side of Queen Street, between Broadway and Devenish Street.

16. Motorists may park on—

Parking permitted.

- (a) the northern side of Sorzano Street, between Queen Street and Prince Street and on the southern side, between King Street and Woodford Street;

LAWS OF TRINIDAD AND TOBAGO

336

Chap. 48:50

Motor Vehicles and Road Traffic

[Subsidiary]

Traffic Control Regulations

- (b) the western side of King Street, between Lopez Street and Sorzano Street;
- (c) the western side of St. Joseph Street, between Broadway and Sorzano Street;
- (d) the western side of Woodford Street, between Hollis Avenue and Sorzano Street;
- (e) the southern side of Farfan Street and Rose Street, between Woodford Street and King Street;
- (f) the southern side of Green Street, between King Street and Woodford Street;
- (g) De Verteuil Street, between Llanos Street and Pro-Queen Street;
- (h) the eastern side of Industry Street, between Anglican Street and Hollis Avenue; and
- (i) the southern side of Robinson Circular Road, between Pro-Queen Street and Railway Street.

No entry to maxi-taxis.

17. Maxi-taxis are prohibited on—

- (a) Broadway, between Prince Street and Queen Street;
- (b) Queen Street, between Broadway and Hollis Avenue; and
- (c) Railway Road Extension, between Railway Road and the Eastern Main Road.

PART V

SANGRE GRANDE

One-way traffic.

18. Motorists shall proceed—

- (a) in a westerly direction on River Street, between Foster Road and Ojoe Road; and
- (b) in a southerly direction on Railway Extension Road, between River Street and Brierley Street.

LAWS OF TRINIDAD AND TOBAGO

Motor Vehicles and Road Traffic

Chap. 48:50

337

Traffic Control Regulations

[Subsidiary]

PART VI

MARABELLA

19. Motorists shall proceed in an easterly direction on Market Street, between the Southern Main Road and Industry Lane. One-way traffic.

PART VII

ST. MARGARET'S

20. Old Southern Main Road at its intersection with Ramdhany's Road is deemed a major road. Major road.

PART VIII

TOBAGO

21. Parking is prohibited on— Parking prohibited.

- (a) Gardenside Street, between Darrell Spring Road and Carrington Street from 7.00 a.m. to 5.00 p.m. from Mondays to Fridays;
- (b) Picton Street, between 7.00 a.m. to 5.00 p.m. from Mondays to Fridays.

22. Motorists may proceed in both directions on Hamilton Street. Two-way traffic.

23. Motor vehicles weighing over three thousand kilograms proceeding North along Jerningham Street may turn left onto Piggott Street. Left turn.

24. Motorists— Right turn.

- (a) driving motor vehicles weighing over three thousand kilograms proceeding West on Hamilton Street may turn right onto Carrington Street;
- (b) proceeding South on Wilson Road from the Claude Noel Highway may turn right onto Dutch Fort Street;
- (c) proceeding North along Castries Street may turn right onto Carrington Street.

25. Motorists proceeding West on Carrington Street may continue to do so beyond its intersection with Castries Street. Carrington Street.

LAWS OF TRINIDAD AND TOBAGO

338

Chap. 48:50

Motor Vehicles and Road Traffic

[Subsidiary]

Traffic Control Regulations

- No right turn. **26.** Motorists proceeding out of the Scotia Bank Car Park shall not turn right into Gardenside Street.
- Goods vehicles. **27.** No more than six goods vehicles may be parked at Scarborough Market Square, adjacent to Wilson Road from Mondays to Fridays.
- Road closure. **28.** The following roads shall be closed to vehicular traffic:
 (a) Silk Cotton Trace, from Crompstain Trace southwards;
 (b) Gaskin Bay Road, from a point two hundred and thirty metres South of Store Bay Local Road southwards;
 (c) Killigwyn Bay Road, from a point two hundred and thirty metres South of Store Bay Local Road southwards.

PART IX

PRINCES TOWN

- Two-way traffic. **29.** Motorists may proceed in both directions on Railway Road.
- No right turn. **30.** Motorists proceeding in a westerly direction on the Naparima-Mayaro Road shall not turn right onto Railway Road.
- No left turn. **31.** Motorists proceeding in an easterly direction on the Naparima-Mayaro Road shall not turn left onto Railway Road.
- Maxi-taxi stand. **32.** Maxi-taxis plying for hire shall park on Tramline Street, from a point fifty-five metres West of the intersection of the Naparima-Mayaro Road and Railway Road.

PART X

CHAGUARAMAS

- Speed limit. **33.** Motorists may not exceed a speed limit of fifty kilometres per hour on the following roads:
 (a) Airways Road;
 (b) Tucker Valley Road;

- (c) Bellerand Road;
- (d) Edith Falls Road; and
- (e) Elder Road.

PART XI

SAN JUAN

34. Motorists shall proceed—

One-way streets.

- (a) in a northerly direction only on Saddle Road from Eastern Main Road to Real Street from 3.00 p.m. to 8.00 p.m. on Mondays to Fridays except on Public Holidays;
- (b) in a northerly direction only on Saddle Road between Real Street and Mission Road from 7.00 a.m. to 9.00 a.m. and from 3.00 p.m. to 8.00 p.m. on Mondays to Fridays and from 7.00 a.m. to 2.00 p.m. on Saturdays except on Public Holidays.

PART XII

GENERAL

35. The maximum MGW allowed on the following main roads are:

Weight limits on main roads.

Arima-Blanchisseuse Road	8 tons
Brasso-Tamana Road	8 tons
Brasso-Chickland Road	5 tons
Brighton Road	8 tons
Caparo Valley-Brasso Road	8 tons
Caroni Savannah Road	5 tons
Cunapo Southern Road	5 tons
Caura Royal Road	5 tons
Cedar Hill Road	8 tons
Guaracara-Tabaquite Road	8 tons
La Pastora Road	5 tons
Long Circular Road	8 tons
Manzanilla-Mayaro Road	5 tons
Mayaro-Guayaguayare Road	5 tons
Morne Coco Road	5 tons
Maracas Royal Road	5 tons
Valencia Road	5 tons

LAWS OF TRINIDAD AND TOBAGO

340

Chap. 48:50

Motor Vehicles and Road Traffic

[Subsidiary]

Traffic Control Regulations

Removal and
impounding of
vehicles
unlawfully
parked.
Ch. 48:50.

36. Without prejudice to any other liability incurred by the commission of a summary offence, vehicles found parked in contravention of these Regulations may be removed by the Police and impounded and dealt with in accordance with section 108(1)(b) of the Motor Vehicles and Road Traffic Act.

**MOTOR VEHICLES (SEAT BELT ASSEMBLIES)
REGULATIONS**

ARRANGEMENT OF REGULATIONS

REGULATION

1. Citation.
2. Interpretation.
3. Acceptable seat belt assembly.
4. Required standard of seat belt assemblies.
5. Anchorage points.
6. All motor vehicles to be fitted with seat belt assemblies.
7. Additional requirements in respect of seat belt assemblies.
8. Proper installation and configuration of seat belts.
9. Exemption certificate.
10. Commencement.

[Subsidiary]

210/1994.

**MOTOR VEHICLES (SEAT BELT ASSEMBLIES)
REGULATIONS**

made under section 101

Citation. **1.** These Regulations may be cited as the Motor Vehicles (Seat Belt Assemblies) Regulations.

Interpretation. **2.** In these Regulations—

Ch. 48:50.

“Act” means the Motor Vehicles and Road Traffic Act;

“anchorage points” means that part of the motor vehicle which is designed to hold securely in position on the vehicle seat belts for the driver’s seat and the specified passengers’ seats;

“motor vehicles” means a vehicle required, under section 43A and B of the Act, to be fitted with a seat belt;

“seat belt assembly” means an assembly of straps with quick release coupling devices, adjusting devices and an attachment and deployment system which deploys automatically, requires no action by the occupant, is anchored to a power-driven vehicle and is intended to be worn by an occupant of a motor vehicle.

Acceptable seat belt assembly.

3. Every seat belt assembly shall be of a type the designation of which shall be any of the following:

- (a) a lap belt which is a seat belt assembly that is anchored at two points and passes across the front of the wearer’s pelvic region from one side of the hip to the other side;
- (b) a diagonal belt which is a seat belt assembly, that is anchored at two points and passes diagonally across the front of the chest from the hip to the opposite shoulder;
- (c) a three-point belt which is a seat belt assembly, that is anchored at three points and passes across the front of the wearer’s pelvic region and across the front of the chest from the hip to the opposite shoulder;
- (d) any other seat belt assembly that is duly certified by the Trinidad and Tobago Bureau of Standards.

4. (1) Every—

- (a) rigid part of a seat belt assembly namely the release devices, retractors and belt adjusting devices; and
- (b) strap of a seat belt assembly namely the restraining and deployment straps and their material, weave, dimensions and strength,

Required standard of seat belt assemblies.

shall conform to either the Trinidad and Tobago Standard, TTS 31 60 505—Seat Belt Assemblies for Automobiles or the Trinidad and Tobago Standard, TTS 31 60 519—Seat Belt Assemblies for Motor Vehicles or any other standard approved by the Trinidad and Tobago Bureau of Standards.

(2) Every seat belt assembly shall have legibly and permanently affixed to it a label showing a mark of certification approved by the Trinidad and Tobago Bureau of Standards (TTBS) which shall include one or more of the following:

- (a) the Trinidad and Tobago Bureau of Standards (TTBS) standard mark;
- (b) the Japanese Industrial Standard Mark (JIS);
- (c) an indication of conformity to the Federal Motor Vehicle Safety Standard (FMVSS 290);
- (d) an approved European Economic Community Mark (EEC);
- (e) an approved Economic Commission for Europe Mark (ECE);
- (f) the British Standards Institute Kitemark (BSI);
- (g) the Australian Standard Mark;
- (h) any other mark approved by the Trinidad and Tobago Bureau of Standards (TTBS).

(3) The label referred to in subregulation (2) shall also have legibly and permanently marked on it the name of the manufacturer of the seat belt or his trade mark and country of origin.

5. Every motor vehicle shall be equipped with anchorage points which shall conform to any standard approved by the Trinidad and Tobago Bureau of Standards.

Anchorage points.

LAWS OF TRINIDAD AND TOBAGO

344

Chap. 48:50 *Motor Vehicles and Road Traffic*

[Subsidiary]

Motor Vehicle (Seat Belt Assemblies) Regulations

All motor vehicles to be fitted with seat belt assemblies.

6. (1) Every motor vehicle shall have fitted to the front seat three-point seat belt assemblies.

(2) Every motor vehicle with seating that accommodates three people at the front shall be equipped with three-point seat belt assemblies fitted to the seating positions of the driver and the passenger at the extreme left or right, as the case may be, and a lap belt in the seating position between that of the driver and the passenger.

(3) The diagonal seat belt assembly may be fitted to a seating position in the front of the vehicle only if there is a compensatory knee panel fitted to the dashboard panel of the vehicle at the seating position in which the diagonal belt is fitted.

Additional requirements in respect of seat belt assemblies.

7. Every seat belt assembly shall be securely affixed to the anchorage points and shall be designed, constructed, installed, maintained, and worn in such a manner that when deployed it will operate satisfactorily and thereby reduce the risk of injury to the person wearing it in the event of a collision or abrupt vehicle deceleration by limiting the mobility of the wearer's body.

Proper installation and configuration of seat belts.

8. (1) Every seat belt shall be installed in such a manner that—

- (a) the straps are not liable to assume a dangerous configuration; and
- (b) when deployed, the risk of the strap slipping from the shoulder and the risk of the straps deteriorating through contact with rigid parts of the vehicle or seat structure is reduced to a minimum.

(2) The installation and configuration of all seat belts and any compensatory knee panels shall conform to either—

- (a) the Trinidad and Tobago Standard (TTS) 31 60 505;
- (b) the Trinidad and Tobago Standard (TTS) 31 60 519; or
- (c) any other standard approved by the Trinidad and Tobago Bureau of Standards.

LAWS OF TRINIDAD AND TOBAGO

Motor Vehicles and Road Traffic

Chap. 48:50

345

Motor Vehicles (Seat Belt Assemblies) Regulations

[Subsidiary]

9. (1) A person who desires to be exempt from wearing a seat belt on grounds other than medical grounds shall apply for an exemption certificate from the Transport Commissioner.

Exemption
certificate.

(2) The Transport Commissioner in providing an applicant with an exemption certificate shall indicate on the certificate whether the exemption is to be permanent or temporary and, if temporary, the duration of the exemption.

(3) A person who holds a valid exemption certificate signed by the Transport Commissioner and has the certificate in his possession shall be exempt from wearing a seat belt.

(4) A holder of a valid exemption certificate or a medical certificate occupying the front seat of a motor vehicle in motion who is not wearing a seat belt shall have either on his person or in the motor vehicle his certificate for production as required under subregulation (5).

(5) A person referred to in subregulation (4) shall, on being so required by any member of the Police Service, give his name and address and produce his certificate.

(6) A person who fails to comply with either subregulation (4) or (5) is liable to a fine of five hundred dollars.

10. These Regulations come into effect on the 1st day of January, 1995.

Commencement.

**TRAFFIC SIGNS AND PEDESTRIAN
CROSSINGS ORDER**

ARRANGEMENT OF CLAUSES

CLAUSE

PART I

PRELIMINARY

1. Citation.
2. Definitions.

PART II

“PELICAN” CROSSINGS

3. Pelican crossing.
4. Vehicular traffic light signals.
5. Pedestrian light signals.
6. Manner of indicating vehicular approach to “Pelican” crossings.
7. Manner of placing traffic signals.
8. Significance of vehicular traffic light signals.
9. Significance of traffic signs for pedestrians.
10. Prohibitions against the waiting of vehicles and pedestrians at “Pelican” crossings.
11. Imperfect traffic signals at “Pelican” crossings.

PART III

“ZEBRA” PEDESTRIAN CROSSING

12. “Zebra” crossings.
13. “Zebra” controlled area.
14. Variation of number of marks.
15. *(Repealed by LN 241/2001).*
16. Traffic signs (Globes).
- 16A. Traffic signs (Wig Wags).
17. Prohibitions against the waiting of vehicles and pedestrians.
18. Prohibition against waiting and overtaking.
19. Precedence of pedestrian over vehicles.
20. Imperfections of “Zebra” crossing and “Zebra” controlled area.

SCHEDULE.

**TRAFFIC SIGNS AND PEDESTRIAN
CROSSINGS ORDER**

1/1993.
[241/2001].

made under section 64(2)

PART I

PRELIMINARY

1. This Order may be cited as the Traffic Signs and Pedestrian Crossings Order. Citation.

2. (1) In this Order—

Definitions.

“the Act” means the Motor Vehicles and Road Traffic Act;

Ch. 48:50.

“appropriate authority” means the Minister or any person acting under his directions exercising the powers under this Order;

“crossing” or “Pedestrian crossing” means a crossing for pedestrian crossing established under clause 3 or clause 12;

“carriageway” does not include that part of any road which consists of a street refuge or central reservation, whether within the limits of a crossing or not;

“central reservation” means any provision, not consisting of a street refuge, made in a road for separating one part of the carriageway of that road from another part of that carriageway for the safety or guidance of vehicular traffic using that road;

“Diagram” means a diagram set out in the Schedule;

Schedule.

“one-way road” means a road on which the driving of any vehicle is prohibited otherwise than in a specific direction;

“pelican crossing” means a crossing, the presence and limits of which are indicated in accordance with clause 3;

“stop line” in relation to the driver of a motor vehicle approaching a “Pelican” crossing means the white line indicating the approach to that crossing which is parallel to the limits of the crossing and on the same side of the crossing as the driver;

“uncontrolled ‘zebra’ crossing” means a “zebra” crossing at which traffic is not for the time being controlled by a constable in uniform or other person authorised by the Act;

“ ‘Zebra’ crossing” means a crossing the presence and limits of which are indicated in accordance with clause 12;

“ ‘Zebra’ controlled area” means, in relation to a “zebra” crossing the area of the carriageway in the vicinity of the crossing and lying on both sides of the crossing or on one side of the crossing, being an area the presence and limits of which are indicated in accordance with clause 13.

(2) The terms and expressions used in this Order, but not defined, shall have the same meanings assigned to them in the Act.

PART II

“PELICAN” CROSSINGS

Pelican crossing.

3. The traffic signs which are to be placed at or near a crossing for the purpose of constituting it a “Pelican” crossing shall consist of a combination of—

- (a) vehicular traffic light signals;
- (b) pedestrian light signals; and
- (c) indicators for pedestrians,

of the size, colour and type as hereinafter provided.

Vehicular traffic light signals. [241/2001].

4. The vehicular traffic light signals shall be as follows:

- (a) three lights shall be used, one red, one amber and one green;
- (b) the lamps showing the aforesaid lights shall be arranged either vertically or horizontally;
- (c) in the vertical arrangement the lamp showing the red light shall be the uppermost and that showing the green light the lowermost;
- (d) in the horizontal arrangement the lamp showing the red light shall be to the left side and the one showing the green light to the right side;
- (e) each lamp shall be separately illuminated;
- (f) the effective diameter of the amber and green lenses shall not be less than 200 millimetres;

- (g) the effective diameter of the red lens shall not be less than 300 millimetres;
- (h) the height of the centre of the lens in the lamp showing the green light from the surface of the carriageway shall not be less than 1.2 metres;
- (i) the distance from the edge of a lens to the edge of the next closest lens shall not be more than 15 millimetres;
- (j) *(Deleted by LN 241/2001)*;
- (k) the design of the signals shall meet the specifications given in Diagram 1 in the Schedule. Schedule.

5. (1) The pedestrian light signals shall be of the size, colour and type indicated in Diagram 1 in the Schedule. Pedestrian light signals. Schedule.

(2) The height of the lower edge of the container enclosing the light signals from the surface of the carriageway shall not be less than 2.1 metres and not more than 2.6 metres.

(3) The said signals shall be so designed that—

- (a) the red icon can be internally illuminated by a steady light or by a flashing light;
- (b) the green icon can be internally illuminated by a steady light; and
- (c) where one signal is illuminated the other is not.

6. (1) Subject to the following provisions of this Order, the approach for vehicular traffic to a “Pelican” crossing shall be indicated by a number of lines marked on the carriageway as is shown in Diagrams 2, 3 and 4 in the Schedule. Manner of indicating vehicular approach to “Pelican” crossings. Schedule.

(2) On either side of a “Pelican” crossing and parallel to it and 1800 millimetres away there shall be a transverse stop line 200 millimetres wide painted in white from the edge of the carriageway to its centre on that side of the carriageway on which vehicles approach the crossing in the case of a road that is not a one-way road, and across the entire width of the carriageway in the case of a road that is a one-way road.

LAWS OF TRINIDAD AND TOBAGO

350

Chap. 48:50

Motor Vehicles and Road Traffic

[Subsidiary]

Traffic Signs and Pedestrian Crossings Order

- (3) In the case of a road not being a one-way road—
- (a) there shall be a longitudinal continuous white line 150 millimetres wide and 15 metres long along the centre of the carriageway extending from the end of the transverse stop line away from the crossing followed by longitudinal broken line 150 millimetres wide extending from the end of the aforesaid continuous white line and consisting of three strips 5.0 metres long and three gaps 2.0 metres long arranged alternately in such a manner that the first gap adjoins the continuous white line;
 - (b) there shall also be marked a continuous yellow line 100 millimetres wide extending from the extremity of the transverse stop line that is nearer the edge of the carriageway, away from the crossing along and parallel with the edge of the carriageway for a distance of 5 metres.

(4) In the case of a road that is a one-way road, there shall be marked a continuous yellow line 100 millimetres wide extending from either extremity of the transverse stop line away from the crossing along and parallel with the edge of the carriageway for a distance of 5 metres.

(5) Where there is a road refuge or central reservation on a road the transverse stop line referred to in this clause shall extend from the edge of the carriageway, to the road refuge or central reservation.

(6) No vehicle shall be parked on a “Pelican” crossing, or on any portion of the carriageway within the limits defined by the yellow line referred to in subclauses (3) and (4).

7. The light signals at or near any “Pelican” crossing shall be so arranged that—

- (a) each vehicular traffic light signal shall face the stream of traffic it is intended to control;
- (b) each pedestrian light signal at either end of the crossing shall be so placed as to be clearly visible to any person who is about to use the crossing at the other end of the crossing.

Manner of placing traffic signals.

8. (1) The vehicular traffic light signals at a “Pelican” crossing shall convey the following meanings:

Significance of vehicular traffic light signals.

- (a) the full green signal that vehicular traffic may proceed beyond the stop line and across the crossing;
- (b) the full amber signal shown alone means that vehicular traffic shall not proceed beyond the stop line, or if the stop line is not for the time being visible, beyond the traffic light signal facing traffic on the side of the carriageway on which vehicles approach the crossing, except in the case of a vehicle which when the amber signal shown, is so close to the said line or signal that it cannot safely be stopped before passing the line or signal;
- (c) the combination of the red signal and the full amber signal shall be taken to denote an impending change in the indications given by the signal from red to green but shall not be taken to alter the prohibitory significance of the red signal;
- (d) the red light means that vehicular traffic shall not proceed beyond the stop line, or if the stop line is not for the time being visible, or there is no stop line beyond the traffic light signal facing traffic on the side of the carriageway on which vehicles approach the crossing;
- (e) the green arrow signal shown alone shall be taken to indicate that vehicular traffic may proceed beyond the stop line, but only in the direction indicated by the arrow;
- (f) the combination of the red signal and the green arrow signal shall be taken as prohibiting vehicular traffic to proceed beyond the stop line on the carriageway provided in conjunction with the signals except when proceeding in the direction indicated by the arrow;
- (g) the combination of the red signal and the amber arrow signal shall be taken to indicate that vehicular traffic is prohibited from proceeding

beyond the stop line on the carriageway provided in conjunction with the signals except when proceeding in the direction indicated by the arrow and that vehicles so proceeding shall give way to vehicles proceeding across their path;

- (h) the flashing red signal shall be taken to indicate that vehicular traffic shall stop at the stop line on the carriageway provided in conjunction with the signals and proceed when it is safe to do;
- (i) the flashing amber signal shall be taken to indicate that vehicular traffic shall reduce speed and not proceed beyond the stop line until it is safe to proceed.

(2) Vehicular traffic shall pass the traffic light signal in accordance with subclause (1) and in so doing shall proceed with due regard to the safety of other users of the road, and subject to the direction of any constable or traffic warden in uniform who may be engaged in the regulation of traffic.

Significance of traffic signs for pedestrians.

9. The traffic signs for pedestrians at a “Pelican” crossing shall convey the following warnings and information:

- (a) the red light shown by the pedestrian light signals means that the pedestrian shall not use the crossing;
- (b) the green light shown by the pedestrian light signal means that the pedestrian may use the crossing, and drivers of vehicles shall not cause their vehicles to enter the limits of the crossing while the pedestrian is in the act of crossing;
- (c) where a flashing red light is shown by the pedestrian light signal—
 - (i) a pedestrian who is already on the crossing when the flashing red light is first shown, may continue to use the crossing;
 - (ii) vehicular traffic may proceed across the crossing, but if the pedestrian is on the carriageway within the limits of the

crossing before any part of the vehicle has entered those limits, the pedestrian has the right of precedence within those limits over that vehicle;

- (iii) a pedestrian who is not already on the crossing when the flashing red light is first shown shall not start to cross the carriageway.

10. (1) The driver of a vehicle shall not cause the vehicle or any part thereof to stop within the limits of a “Pelican” crossing unless either he is prevented from proceeding by circumstances beyond his control or it is necessary for him so to stop in order to avoid an accident.

Prohibitions against the waiting of vehicles and pedestrians at “Pelican” crossings.

(2) A pedestrian shall not remain on the carriageway within the limits of a “Pelican” crossing longer than is necessary for the purpose of passing over the crossing with reasonable despatch.

11. A “Pelican” crossing shall not be deemed to have ceased to be indicated in accordance with this Order by reason only of the imperfection, discolouration or disfigurement of any light or markings, or the failure of any light.

Imperfect traffic signals at “Pelican” crossing. [241/2001].

PART III

“ZEBRA” PEDESTRIAN CROSSINGS

12. (1) “Zebra” crossings shall be denoted on a road by alternate black and white stripes painted parallel to the kerb of the said road as shown in Diagram 5 in the Schedule.

“Zebra” crossings. Schedule.

(2) Each stripe shall be not less than 2.5 metres and not more than 10 metres in length, and not less than 0.04 metre and not more than 0.60 metre in width.

13. (1) The traffic signs which are to be placed on a road for the purpose of constituting a “Zebra” controlled area lying either on both sides of the limits of the crossing or only on one side of

“Zebra” controlled area. [241/2001].

LAWS OF TRINIDAD AND TOBAGO

354

Chap. 48:50

Motor Vehicles and Road Traffic

[Subsidiary]

Traffic Signs and Pedestrian Crossings Order

Schedule.

such limits and indicating the presence and limits of such an area shall consist of a pattern of lines and type shown in Diagram 6 in the Schedule with the measurements as hereinafter provided.

(2) The pattern of lines shall, subject as hereinafter provided, consist of—

Schedule.

- (a) a transverse broken line (hereinafter referred to as the “give-way line”), as indicated in Diagram 6 in the Schedule placed across the carriageway 1 metre from and parallel to the imaginary line caused by the nearest extremities of the black and white strips indicating the limits of the crossing;
- (b) two or more longitudinal white broken lines (hereinafter referred to as “zig-zag lines”) placed on the carriageway, or where the road is a dual carriageway road on each part of the carriageway, zig-zag lines containing not less than 4 and not more than 18 white marks and extending away from the crossing at a point 150 millimetres from the nearer edge of the give-way line on the same side of the crossing for such a distance as the appropriate authority may think fit having regard to the angle of the crossing in relation to the edge of the carriageway at the place where the crossing is situated and any other features of the carriageway at that point.

(3) Each mark referred to in subclause (c) shall be 2000 millimetres in length and not less than 100 millimetres and not more than 150 millimetres in width, and there shall be a space of 150 millimetres separating each mark from the one nearest to it.

(4) Each mark contained in a give-way line or in a zig-zag line may be illuminated by use of a reflecting material.

Variation of number of marks.

14. Where the appropriate authority is satisfied, in relation to a particular area in the vicinity of a “Zebra” crossing, that by reason of the layout of or character of the roads in the vicinity

of the crossing it would be impractical to lay the lines as indicated in Diagram 6 in the Schedule and in accordance with clause 13(2), the following variations are permitted: Schedule.

- (a) the number of marks in each zig-zag line may be reduced from 4 to not less than 2;
- (b) a mark contained in a zig-zag line may be varied in length so as to extend for a distance less than 2 metres but not less than 1 metre, and where such variation is made as respects a mark each other mark in each zig-zag line shall be of the same or substantially the same length as that mark, so, however, that the number of marks in each zig-zag line shall not be more than 4 and less than 2.

15. (Repealed by LN 241/2001).

16. (1) The traffic signs which may be placed at or near a crossing for the purpose of indicating it as a “Zebra” crossing shall consist of globes as indicated in Diagram 7 in the Schedule or danger warning traffic signs. Traffic signs (Globes).
Schedule.

(2) Such globes shall be—

- (a) yellow in colour;
- (b) not less than 27 millimetres and not more than 335 millimetres in diameter; and
- (c) so mounted on posts that the height of the lowest part of the globe is not less than 2.1 metres and not more than 3.1 metres above the surface of the ground in the immediate vicinity.

(3) Such globes shall be illuminated by a flashing light or by a constant light.

(4) Each post upon which a globe is mounted shall be coloured black and white in alternate horizontal bands, and shall be placed in such a position as to be clearly visible to approaching traffic.

LAWS OF TRINIDAD AND TOBAGO

356

Chap. 48:50

Motor Vehicles and Road Traffic

[Subsidiary]

Traffic Signs and Pedestrian Crossings Order

(5) Each such band shall not be less than 275 millimetres nor more than 335 millimetres in width and shall not be marked on any container fixed on any such post which enclosed the apparatus for providing the illumination of a globe.

Traffic signs
(Wig Wags).
[241/2001].
Schedule.

16A. (1) The traffic signs which may be placed at or near a crossing for the purpose set out in clause 16 may also consist of Wig Wags as indicated in Diagram 8 of the Schedule.

(2) Wig Wags shall be—

(a) 300 mm in diameter; and

(b) so mounted on posts at an average height of 2.5 m above the surface of the ground in the immediate vicinity of the crossing.

(3) The container which houses the apparatus for illumination of a Wig Wag shall be yellow or black in colour.

(4) Wig Wags shall be illuminated by a flashing amber signal.

(5) Each post upon which a Wig Wag is mounted shall be coloured black and white in alternative horizontal bands, and shall be placed in such a position as to be clearly visible to approaching traffic.

(6) Each band shall be 300 mm in width and shall not be marked on any container which encloses the apparatus for providing the illumination of a Wig Wag.

Prohibitions
against the
waiting of
vehicles and
pedestrians.

17. (1) The driver of a vehicle shall not cause the vehicle or any part thereof to stop within the limits of a “Zebra” crossing unless either he is prevented from proceeding by circumstances beyond his control or it is necessary for him to do so in order to avoid an accident.

(2) No pedestrian shall remain on the carriageway within the limits of “Zebra” crossing longer than is necessary for the purpose of passing over the crossing with reasonable despatch.

Prohibition
against waiting
and overtaking.

18. The driver of a vehicle shall not park, stop his vehicle, or overtake another vehicle within a “Zebra” controlled area.

LAWS OF TRINIDAD AND TOBAGO

Motor Vehicles and Road Traffic

Chap. 48:50

357

Traffic Signs and Pedestrian Crossings Order

[Subsidiary]

19. (1) A pedestrian shall not cross the carriageway within the vicinity of a “Zebra” crossing except within the limit of the give-way line.

Precedence of pedestrian over vehicles. [241/2001].

(2) Every pedestrian on a “Zebra” crossing has precedence over any vehicle and the driver of the vehicle shall accord such precedence to the pedestrian where the pedestrian came onto the “Zebra” crossing prior to the vehicle.

20. (1) A “Zebra” crossing shall not be deemed to have ceased to be indicated in accordance with this Order by reason only of the imperfection, discolouration or disfiguration of any globe, danger warning traffic sign or post, or the failure of the illumination of any globe or danger warning traffic sign.

Imperfections of “Zebra” crossing and “Zebra” controlled area.

(2) A “Zebra” controlled area or its limits shall not be deemed to have ceased to be indicated in accordance with this Order by reason only of the imperfection, discolouration or partial displacement of either a terminal line or one or more of the marks comprised in a give-way line or a zig-zag line, so long as the general indication of any such line is not thereby materially impaired.

Clause 4.
Diagram 1.

SCHEDULE

PELICAN CROSSING—STREET FURNITURE

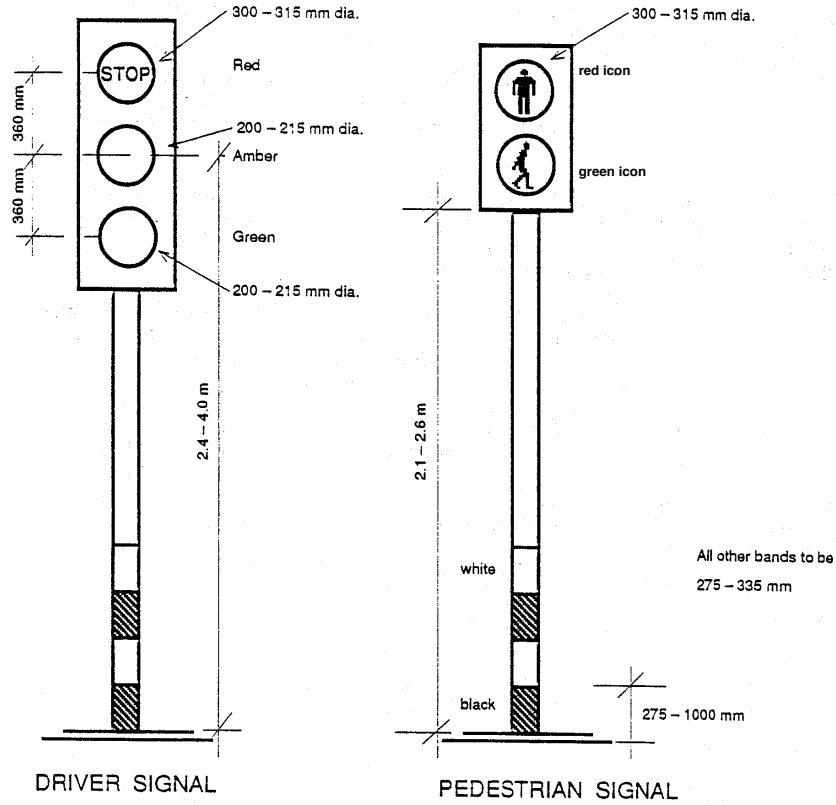

**CONTROLLED CROSSING—ROAD MARKINGS
(ONE-WAY STREET WITH MORE THAN ONE LANE)**

Clause 5.
Diagram 2.

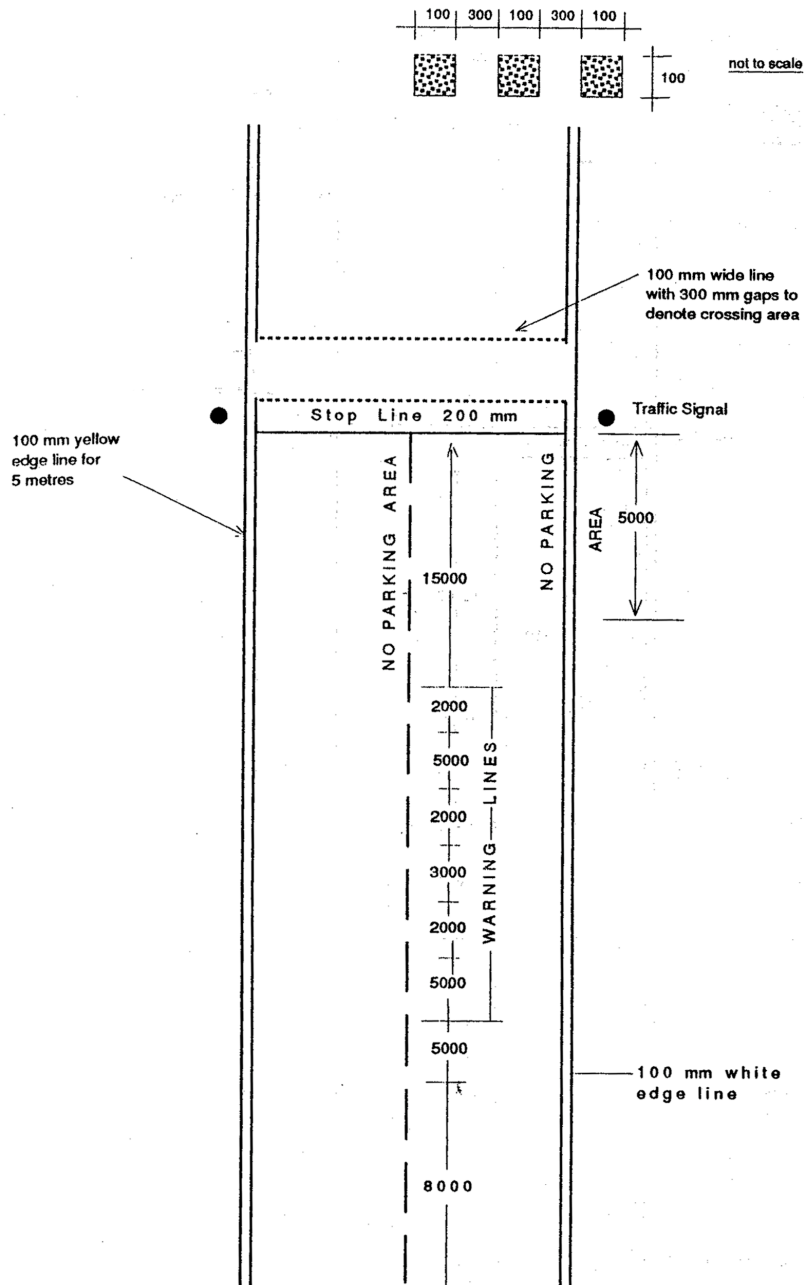

Clause 5.
Diagram 3.

**CONTROLLED CROSSING—ROAD MARKINGS
(SINGLE CARRIAGEWAY—2-DIRECTIONAL TRAFFIC)**

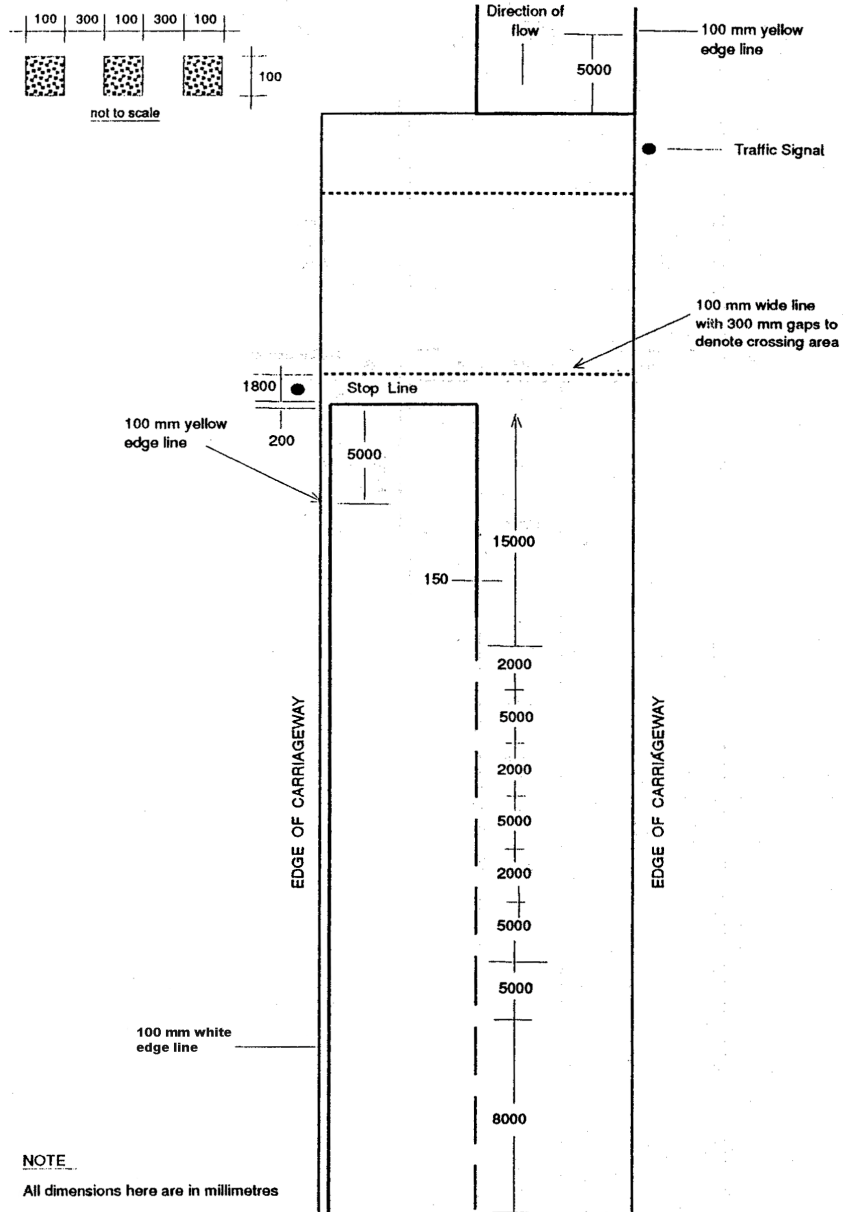

**CONTROLLED CROSSING—ROAD MARKINGS
(ONE-WAY ONE-LANE STREET)**

Clause 5.
Diagram 4.

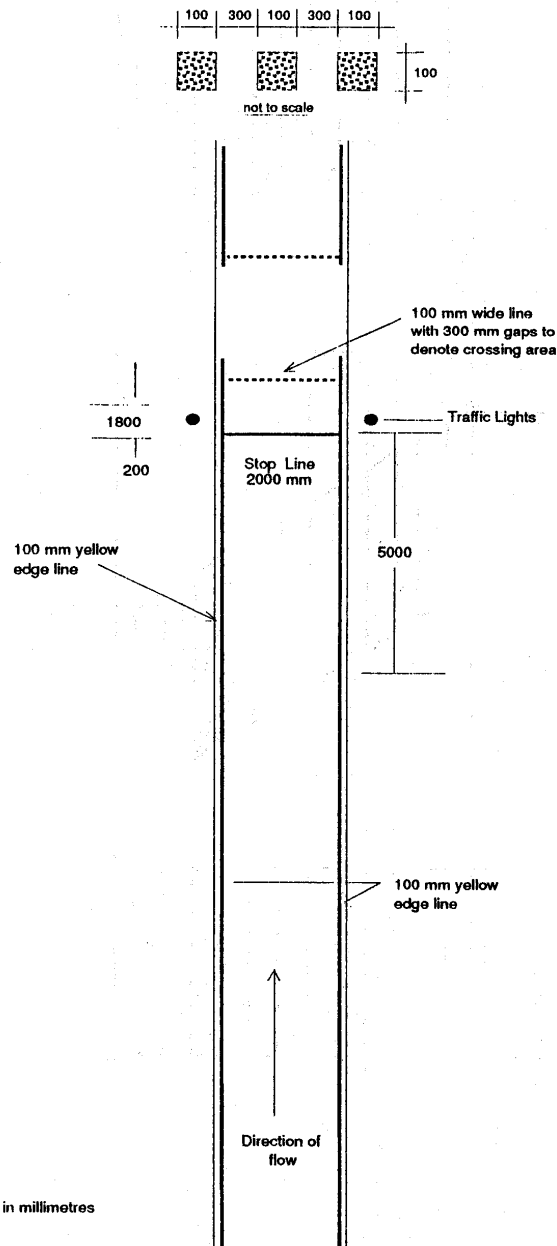

NOTE
All dimensions here are in millimetres

PEDESTRIAN CROSSING

POSSIBLE LAYOUTS

Clause 12,
Diagram 5.

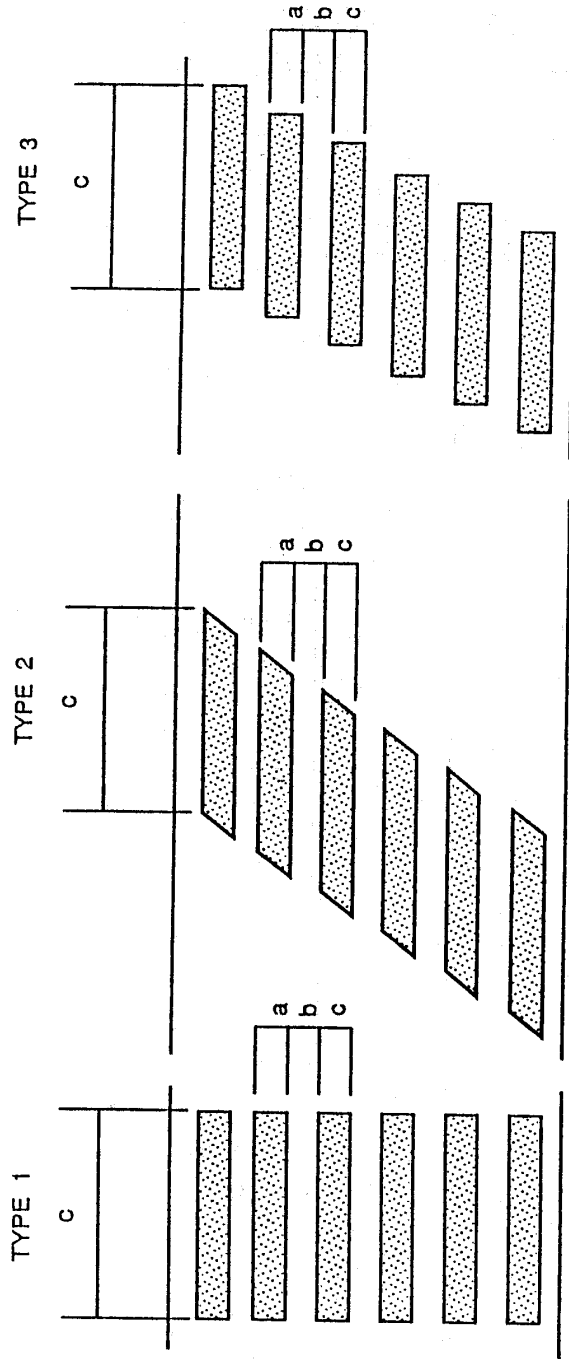

Abbreviations

- v = speed (65%) of vehicular traffic.
- c = width of longitudinal marking
- a = thickness of longitudinal marking
- b = space between longitudinal markings

**ZEBRA CROSSINGS—ROAD MARKINGS
(SINGLE CARRIAGEWAY) 2-DIRECTIONAL TRAFFIC**

Clause 13.
Diagram 6.

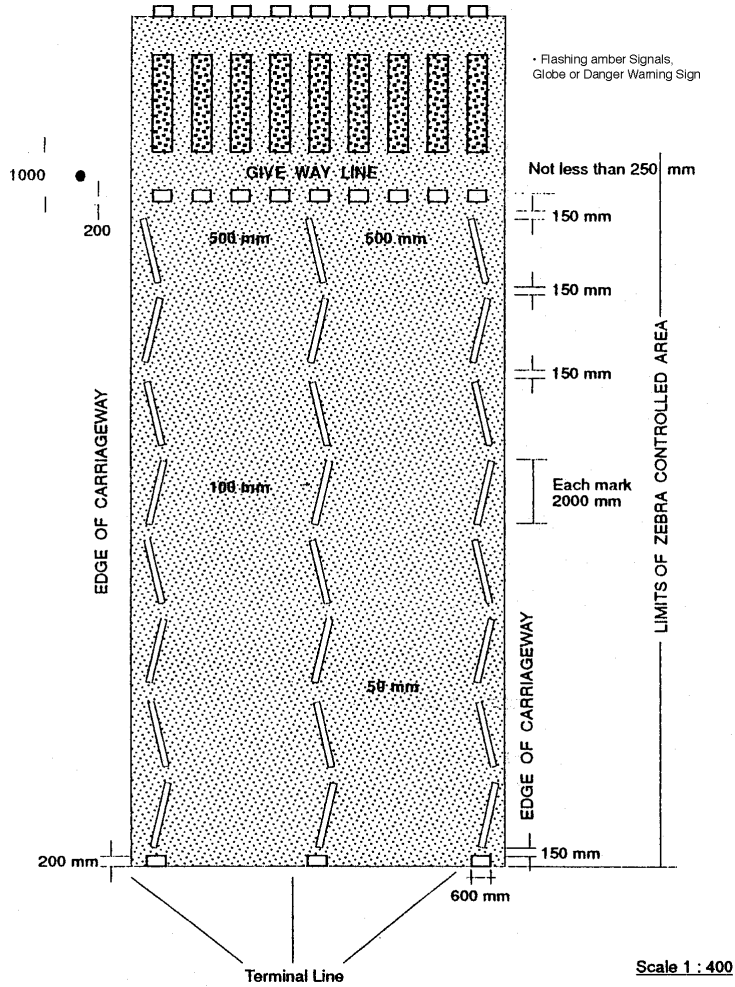

Notes

- 1) Each zig-zag line need not contain the same number of marks.
- 2) Number of marks on zig zag line may vary from 2 to 8.
- 3) All marks are to be painted in white.
- 4) All dimensions are in millimetres.

Clause 16.
Diagram 7.

ZEBRA CROSSING—STREET FURNITURE

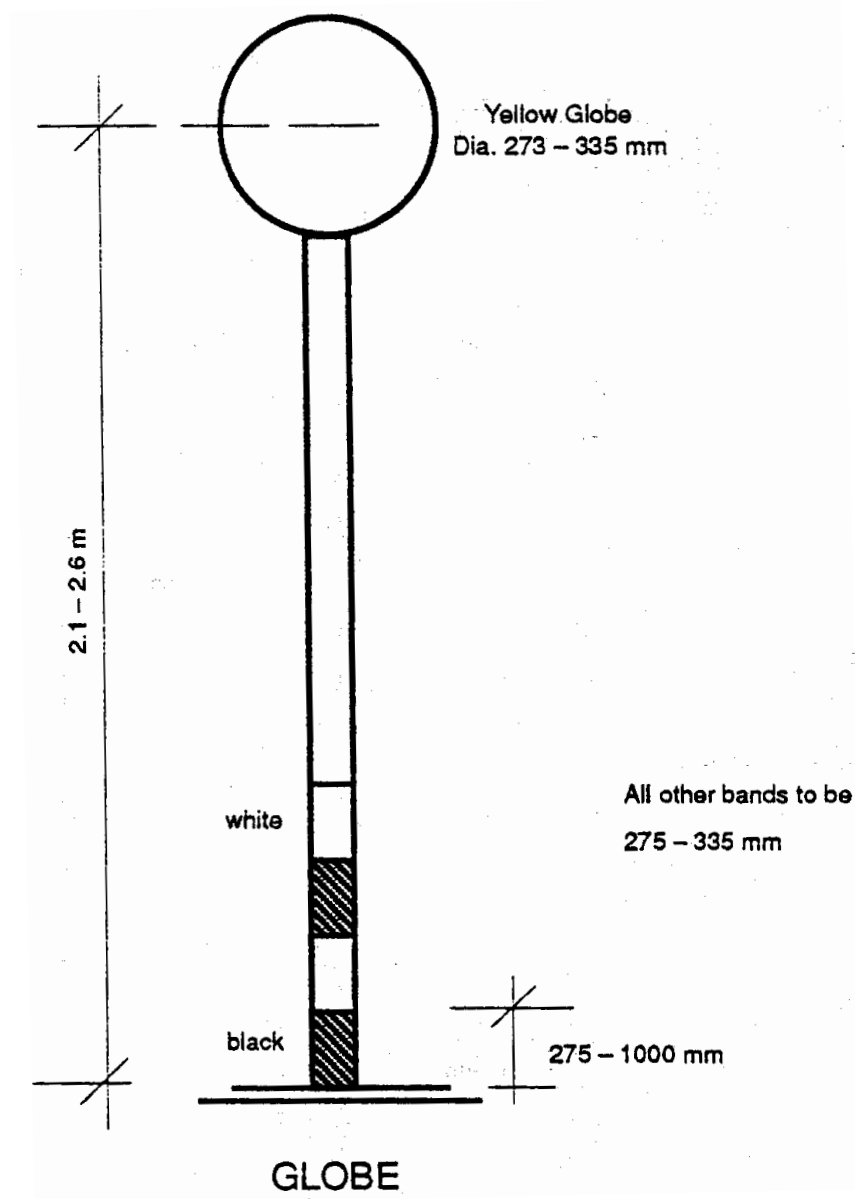

**ZEBRA CROSSING—STREET FURNITURE
WIG WAG**

Clause 16A.
Diagram 8.

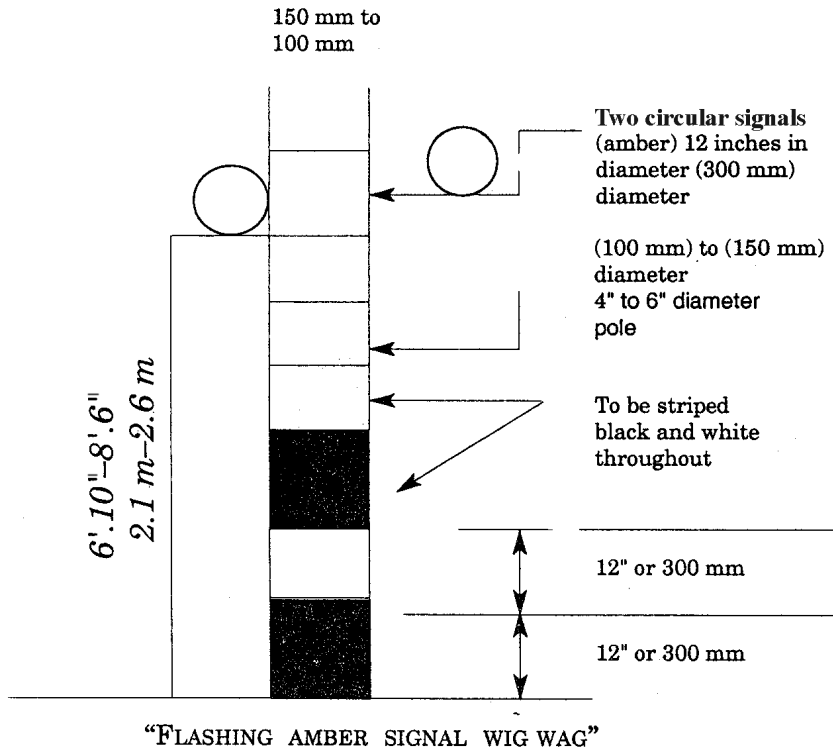

TRAFFIC CONTROL TAXI STAND LOCATION ORDER

ARRANGEMENT OF CLAUSES

CLAUSE

1. Citation.

PART I

PORT-OF-SPAIN

2. Conventional taxi stand location.
3. One-way traffic.
4. Maxi-taxi stand.
5. No entry—taxis and maxi-taxis.
6. No entry—maxi-taxis only.
7. Parking prohibited.
8. No plying for hire.
9. No right turn.

PART II

GENERAL

10. Offence.
-

TRAFFIC CONTROL TAXI STAND LOCATION ORDER

113/1988.

made under section 65

1. This Order may be cited as the Traffic Control Taxi Stand Location Order. Citation.

PART I

PORT-OF-SPAIN

2. Taxi drivers plying—

Conventional
taxi stand
location.

- (a) the San Juan route may park on the southern side of Independence Square South, between George Street and Charlotte Street and facing North on the western side of George Street, between Independence Square South and South Quay;
- (b) the Chaguanas/San Fernando route may park on the southern side of Independence Square North, between Henry Street and Charlotte Street;
- (c) the Cunupia/Enterprise “Round-the-Road” route may park on the southern side of Independence Square North, between George Street and Charlotte Street;
- (d) the St. James route may park on the northern side of Hart Street, between Abercromby Street and Frederick Street;
- (e) the St. Ann’s route may park on the southern side of Hart Street between Abercromby Street and Frederick Street;
- (f) the Belmont/Gonzales route may park on the western side of Charlotte Street, between Queen Street and Prince Street;
- (g) the Carenage route may park on the southern side of Tragarete Road, between Green Corner and Edward Street;

LAWS OF TRINIDAD AND TOBAGO

368

Chap. 48:50

Motor Vehicles and Road Traffic

[Subsidiary]

Traffic Control Taxi Stand Location Order

- (h) the Maraval route may park on the southern side of Duke Street, between George Street and Charlotte Street and on the western side of George Street, between Duke Street and Prince Street;
- (i) the Pashley Street/Prizgar Lands route may park on the southern side of Queen Street, between Nelson Street and Duncan Street;
- (j) the Trou Macaque route may park on the southern side of Independence Square North, between Nelson Street and Duncan Street;
- (k) the Cascade route may park on the northern portion of the western side of Charlotte Street, between Queen Street and Prince Street;
- (l) the Morvant route may park on the northern side of Independence Square North, between George Street and Nelson Street;
- (m) the Long Circular route may park on the southern side of Independence Square North, between Cipriani Circle and Chacon Street;
- (n) the Diego Martin/Petit Valley route may park on the southern side of Independence Square North, between Chacon Street and Abercromby Street, on the eastern side of Abercromby Street, between Independence Square North and South and on the northern side of Independence Square South, between Chacon Street and Abercromby Street;
- (o) the Tunapuna/Curepe route may park on the southern side of Independence Square North from five metres East of Broadway to five metres West of Henry Street;
- (p) the Arima/Sangre Grande route may park facing a south-westerly direction on the northern side of Independence Square South from a point five metres West of Henry Street to a point five metres West of Broadway; and

- (q) from the Marine Square taxi stand may park facing East on the south-western section of Cipriani Circle and on the northern side of Independence Square South, between Cipriani Circle and Chacon Street.

3. Motorists shall proceed—

One-way traffic.

- (a) in a northerly direction only on Charlotte Street, between Independence Square South and South Quay;
- (b) in a southerly direction only on Henry Street, between Independence Square South and South Quay.

4. Maxi-taxi drivers plying—

Maxi-taxi stand.

- (a) the West Bound route may park on the Independence Square parking lots, between Chacon Street and Abercromby Street;
- (b) the Maraval route may park on the southern side of Duke Street, between Charlotte Street and Henry Street;
- (c) the Carenage route may park facing East on the northern side of Park Street, between Edward Street and Green Corner;
- (d) the Sangre Grande/La Horquetta route may park facing North on the western side of the parking allotment on Broadway;
- (e) the Maloney/Arima via the Churchill-Roosevelt Highway route may park facing South on the eastern side of the parking allotment on Broadway;
- (f) the Eastern Main Road route may park facing North on the western side of Charlotte Street, between Independence Square South and South Quay;

LAWS OF TRINIDAD AND TOBAGO

370

Chap. 48:50

Motor Vehicles and Road Traffic

[Subsidiary]

Traffic Control Taxi Stand Location Order

- (g) the Round-the-Road route may park on the eastern side of Charlotte Street within a distance of five metres South of Independence Square North, between Independence Square South and Independence Square North;
- (h) the Long Circular route may park not more than two (2) small maxi-taxis or one (1) large maxi-taxi facing East in the designated spaces just South of Independence Square North on the western side of Cipriani Circle;
- (i) the San Fernando route may park on the southern side of Independence Square South, between Henry Street and Charlotte Street;
- (j) the Morvant route may park on the southern side of Queen Street, between George Street and Nelson Street.

No entry—taxis and maxi-taxis.

5. Taxis and maxi-taxis may not enter the following streets:

- (a) Queen Street, between Henry Street and Abercromby Street;
- (b) Henry Street, between Independence Square North and Queen Street;
- (c) Frederick Street, between Hart Street and Independence Square North.

No entry—maxi-taxis only.

6. Maxi-taxis may not enter—

- (a) Independence Square North, between Chacon Street and a point 12 metres West of the intersection of Independence Square North with Broadway and between a point two metres East of Broadway on Independence Square North to Nelson Street;
- (b) Independence Square South, between Nelson Street and Charlotte Street; and
- (c) George Street, between South Quay and Independence Square South.

LAWS OF TRINIDAD AND TOBAGO

Motor Vehicles and Road Traffic

Chap. 48:50

371

Traffic Control Taxi Stand Location Order

[Subsidiary]

7. Motorists with the exception of taxi drivers operating in taxi stands may not park on— Parking prohibited.

- (a) Independence Square North, between St. Vincent Street and Duncan Street;
- (b) Independence Square South, between Duncan Street and Abercromby Street;
- (c) Prince Street, between Frederick Street and Charlotte Street;
- (d) the eastern side of George Street, between Independence Square South and South Quay;
- (e) the eastern side of Charlotte Street, between South Quay and Independence Square South;
- (f) Henry Street, between Independence Square South and South Quay.

8. Taxi drivers with the exception of taxi drivers operating in taxi stands may not ply for hire their taxis or maxi-taxis on Independence Square North and Independence Square South, between St. Vincent Street and Duncan Street. No plying for hire.

9. Vehicular traffic may not turn North from Independence Square South into the following roads: No right turn.

- (a) George Street;
- (b) St. Vincent Street;
- (c) Henry Street.

**PART II
GENERAL**

10. Any person who contravenes any of the provisions of this Order is guilty of an offence and is liable on summary conviction to a fine of five hundred dollars or to imprisonment for three months. Offence.

LAWS OF TRINIDAD AND TOBAGO

372

Chap. 48:50

Motor Vehicles and Road Traffic

[Subsidiary]

**PORT-OF-SPAIN TRANSIT CENTRE
(TAXI STAND) ORDER**

ARRANGEMENT OF CLAUSES

CLAUSE

1. Citation
2. Taxi stand.
3. Access—Red and Green Band maxi-taxis.
4. Access to taxi stand—6.00 a.m. to 9.00 a.m.
5. Parking, stopping restricted.
6. Parking prohibited.
7. Offence.

**PORT-OF-SPAIN TRANSIT CENTRE
(TAXI STAND) ORDER**

226/1997.

made under section 65

1. This Order may be cited as the Port-of-Spain Transit Centre (Taxi Stand) Order. Citation.

2. That area of the compound of the Public Transport Service Corporation, hereinafter called “the taxi-stand”, which is bounded by the Beetham Highway, Broadway, South Quay and St. Ann’s River is hereby designated as a taxi-stand for the parking of maxi-taxis. Taxi stand.

3. Maxi-taxis plying routes two and three (Red and Green Bands) shall access the taxi stand via the St. Ann’s River bridge. Access—
Red and
Green Band
maxi-taxis.

4. (1) Between the hours of 6.00 a.m. and 9.00 a.m. from Monday to Friday, maxi-taxis shall proceed as follows: Access to taxi
stand—6.00 a.m.
to 9.00 a.m.

(a) maxi-taxis may enter the taxi stand at the western end of the Priority Bus Route and proceed in a westerly direction to the designated off-loading areas on Platforms 1, 2, 3, and 4 and after off-loading proceed in the direction so indicated by way of the Holding Bay to the Ready Bay;

(b) maxi-taxis plying for hire along—

(i) the Port-of-Spain to San Fernando route utilising the Priority Bus Route, the Churchill-Roosevelt Highway and the Solomon Hochoy Highway, may proceed in a westerly direction from the Ready Bay onto Platform 6 to their loading position at Bay A on the western side of the taxi stand and park facing North;

(ii) the Port-of-Spain to Chaguanas route utilising the Priority Bus Route and Solomon Hochoy Highway, may proceed

LAWS OF TRINIDAD AND TOBAGO

374

Chap. 48:50

Motor Vehicles and Road Traffic

[Subsidiary]

Port-of-Spain Transit Centre (Taxi Stand) Order

in a westerly direction from the Ready Bay onto Platform 6 to their loading position at Bay B on the western side of the taxi stand and park facing North;

- (iii) the Port-of-Spain to Arima route utilising the Eastern Main Road, may proceed in a westerly direction from the Ready Bay onto Platform 6 to their loading position at Bay C on the western side of the taxi stand and park facing North;
- (iv) the Port-of-Spain to Sangre Grande route utilising the Eastern Main Road, the Priority Bus Route and the Churchill-Roosevelt Highway, may proceed in a westerly direction from the Ready Bay onto Platform 6 to their loading position at Bay D on the western side of the taxi stand and park facing North;
- (v) the Port-of-Spain to Arima route utilising the Priority Bus Route, may proceed in a westerly direction from the Ready Bay behind Platform 6, then north onto Platform 5 to their loading position at Bay A on the western side of the taxi stand and park facing North;
- (vi) the Port-of-Spain to Maloney route utilising the Priority Bus Route and the Churchill-Roosevelt Highway, may proceed in a westerly direction from the Ready Bay, then north onto Platform 5 to their loading position at Bay B on the western side of the taxi stand and park facing North;
- (vii) the Port-of-Spain to La Horquetta route utilising the Priority Bus Route and the Churchill-Roosevelt Highway, may

- proceed in a westerly direction from the Ready Bay behind Platform 6, then north onto Platform 5 to their loading position at Bay C on the western side of the taxi stand and park facing North;
- (viii) the Port-of-Spain to Morvant route utilising the Eastern Main Road, may proceed in a westerly direction from the Ready Bay behind Platform 6 then north onto Platform 5 to their loading position at Bay D on the western side of the taxi stand and park facing North.
- (2) At all other times, maxi-taxis shall proceed as follows:
- (a) maxi-taxis may enter at the western end of the Priority Bus Route and proceed in a westerly direction to the designated off-loading area on Platform 1, and after off-loading proceed in the direction so indicated to the Ready Bay;
- (b) maxi-taxis plying for hire along—
- (i) the Port-of-Spain to Morvant route utilising the Eastern Main Road; may proceed in a westerly direction from the Ready Bay onto Platform 6 to their loading position at Bay A on the western side of the taxi stand and park facing North;
- (ii) the Port-of-Spain to Arima route utilising the Eastern Main Road, may proceed in a westerly direction from the Ready Bay onto Platform 6 to their loading positions at Bays B, C and D on the western side of the taxi-stand and park facing North;
- (iii) the Port-of-Spain to Sangre Grande route utilising the Eastern Main Road, the Priority Bus Route or the Churchill-Roosevelt Highway, may proceed in a westerly direction from the Ready Bay

LAWS OF TRINIDAD AND TOBAGO

376

Chap. 48:50

Motor Vehicles and Road Traffic

[Subsidiary]

Port-of-Spain Transit Centre (Taxi Stand) Order

behind Platform 6, turning north onto Platform 5 to their loading positions at Bays A and B on the western side of the taxi stand and park facing North;

- (iv) the Port-of-Spain to Chaguanas route utilising the Priority Bus Route and the Solomon Hochoy Highway, may proceed in a westerly direction from the Ready Bay behind Platform 6, then north onto Platform 5 to their loading positions at Bay C on the western side of the taxi stand and park facing North;
- (v) the Port-of-Spain to San Juan route utilising the Eastern Main Road, may proceed in a westerly direction from the Ready Bay behind Platform 6, then north onto Platform 5 to their loading position at Bay D on the western side of the taxi-stand and park facing North;
- (vi) the Port-of-Spain to Maloney route utilising the Priority Bus Route and the Churchill-Roosevelt Highway, may proceed in a westerly direction from the Ready Bay behind Platforms 6 and 5, then onto Platform 4 to their loading positions at Bays A and B on the western side of the taxi stand and park facing North;
- (vii) the Port-of-Spain to La Horquetta route utilising the Priority Bus Route and the Churchill-Roosevelt Highway, may proceed in a westerly direction from the Ready Bay behind Platforms 6 and 5, then north onto Platform 4 to their loading positions at Bays C and D on the western side of the taxi stand and park facing North;

- (viii) the Port-of-Spain to San Fernando route utilising the Priority Bus Route, the Churchill-Roosevelt Highway and the Solomon Hochoy Highway, may proceed in a westerly direction from the Ready Bay behind Platforms 6, 5 and 4, then north onto Platform 3 to their loading positions at Bays A and B on the western side of the taxi stand and park facing North;
- (ix) the Port-of-Spain to Chaguanas route utilising the Churchill-Roosevelt Highway and the Southern Main Road, may proceed in a westerly direction from the Ready Bay behind Platforms 6, 5 and 4, then north onto Platform 3 to their loading position at Bay C on the western side of the taxi stand and park facing North;
- (x) the Port-of-Spain to Arima route utilising the Priority Bus Route, may proceed in a westerly direction from the Ready Bay behind Platforms 6, 5, 4 and 3, then north onto Platform 2 to their loading positions at Bays A, B, C and D on the western side of the taxi stand and park facing North.

5. Maxi-taxis shall not park, stop or wait in the designated areas immediately east or west of the building which houses the Maxi-Taxi (Route 2) Association. Parking, stopping restricted.

6. No vehicles other than maxi-taxis may park in the taxi stand. Parking prohibited.

7. Any person who contravenes the provisions of this Order is liable on summary conviction to a fine of five hundred dollars or imprisonment for a period not exceeding three months. Offence.

**PORT-OF-SPAIN TRANSIT CENTRE (PUBLIC SERVICE
VEHICLE STATION) REGULATIONS**

ARRANGEMENT OF REGULATIONS

REGULATION

1. Citation.
2. Interpretation.
3. Appointment as Public Service Vehicle Station.
4. Issue of permits to owners and operators.
5. Regulation of conduct of owners and operators.
6. Conductor's permit.
7. Holding Bay.
8. Ready Bay.
9. Loading Bay.
10. Refusal of passenger.
11. Cancellation or suspension of permits.
12. Appeals.
13. General.
14. Offence.

SCHEDULE.

PORT-OF-SPAIN TRANSIT CENTRE (PUBLIC SERVICE VEHICLE STATION) REGULATIONS

227/1997.

made under section 101

1. These Regulations may be cited as the Port-of-Spain Transit Centre (Public Service Vehicle Station) Regulations. Citation.

2. In these Regulations— Interpretation.

“Authorised officer” means any member of the management and staff of the Corporation duly authorised by the Corporation; and includes Customer Service Representatives duly appointed by the Corporation, Automotive Licensing Officers, Traffic Wardens, Police Officers and duly precepted Security Officers;

“Corporation” means the Public Transport Service Corporation;

“Holding Bay” means that area of the Corporation’s compound immediately preceding the Ready Bay and designated for use by public service vehicles;

“Loading Bay” means that area of the Corporation’s compound designated for use by public service vehicles for the loading or taking up of passengers;

“Manager” means the person appointed as Manager of the Port-of-Spain Transit Centre;

“Off-loading platform” means that area of the Corporation’s compound designated for the dropping off or discharge of passengers from public service vehicles;

“operator” means the holder of a valid permit under section 6A of the Maxi-Taxi (Amendment) Act, 1994 and includes the driver of a public service vehicle; 3 of 1994.

“owner” means a registered maxi-taxi owner under section 6 of the Maxi-Taxi (Amendment) Act, 1994;

“passenger” means any person who hires a public service vehicle and includes any person who enters the vehicle with the permission of its owner or operator;

“persistent offender” means any person found guilty of a breach of any of these Regulations on more than three occasions;

LAWS OF TRINIDAD AND TOBAGO

380

Chap. 48:50 *Motor Vehicles and Road Traffic*

[Subsidiary] *Port-of-Spain Transit Centre (Public Service Vehicle Station) Regulations*

Ch. 48:53. “public service vehicle” means a maxi-taxi as defined under section 2 of the Maxi-Taxi Act;

“Ready Bay” means that area of the Corporation’s compound immediately preceding the Loading Bay and designated for use by public service vehicles;

Legal Notice No. 226 of 1997. Ch. 48:50. “Transit Centre” means the taxi stand as defined by the Port-of-Spain Transit Centre (Taxi Stand) Order, made under the Motor Vehicles and Road Traffic Act;

“touting” means speaking or making noises or sounds in order to attract the attention of the public or possible passengers, and includes noisome and frequent demands or the persistent following of the public or possible passenger for the purpose of holding out a public service vehicle for hire to the public or possible passenger;

“Users” include owners, operators, conductors and passengers who use the Transit Centre.

Appointment as Public Service Vehicle Station. **3.** (1) That area of the Corporation’s compound which is bounded by the Beetham Highway, Broadway, South Quay and St. Ann’s River is hereby appointed a station for public service vehicles.

(2) The Corporation is authorised to make reasonable charges for the use of any accommodation on its property so provided.

Issue of permits to owners and operators. Schedule. Form 1. **4.** (1) The owner or operator of a public service vehicle who desires to use the Transit Centre shall apply to the Corporation in the manner set out in Form 1 of the Schedule.

(2) Upon receipt of an application form under subregulation (1) and the payment of a fee of one hundred dollars from an owner or twenty-five dollars from an operator, the Corporation upon being satisfied that such owner or operator is a fit and proper person to use the Transit Centre shall issue to such owner or operator a permit in the manner set out in Form 2 of the Schedule.

Schedule. Form 2. (3) The Corporation shall not issue a permit to an owner or operator of any public service vehicle where the vehicle is not registered or does not carry valid insurance.

LAWS OF TRINIDAD AND TOBAGO

Motor Vehicles and Road Traffic

Chap. 48:50

381

Port-of-Spain Transit Centre (Public Service Vehicle Station) Regulations

[Subsidiary]

(4) A permit issued under subregulation (2) shall have a duration of one year from the date of issue and shall be renewable upon application in the manner set out in Form 3 of the Schedule.

Schedule.
Form 3.

5. Any owner or operator of any public service vehicle operating within the Transit Centre who—

Regulation of
conduct of
owners and
operators.

- (a) takes up passengers on the designated off-loading platform or in any other area other than that specifically appointed for such purpose;
- (b) engages in touting;
- (c) employs any person as a conductor who is not the holder of a valid permit issued under these Regulations;
- (d) loiters within the Transit Centre for the purpose of taking up passengers; or
- (e) leaves or permits to be left on any roadway within the Transit Centre any vehicle which has broken down, without taking immediate steps to have it removed to an area so designated by the Corporation without reasonable excuse,

shall be guilty of an offence under these Regulations.

6. (1) A person who is the holder of a Conductor's Permit under the Motor Vehicles and Road Traffic Act shall be required to hold a Conductor's Permit to operate within the Transit Centre.

Conductor's
permit.
Ch. 48:50.

(2) Application for such a permit shall be made in the manner set out in Form 4 of the Schedule.

Schedule.
Form 4.

(3) The Corporation on being satisfied that the applicant is a fit and proper person to operate as a conductor on a public service vehicle within the Transit Centre, shall upon the payment of a fee of twenty-five dollars grant to the successful applicant a permit in the manner set out in Form 2 of the Schedule.

Schedule.
Form 2.

(4) A permit shall have a duration of one year from the date of issue, and shall be renewable upon application in the manner set out in Form 3 of the Schedule.

Schedule.
Form 3.

LAWS OF TRINIDAD AND TOBAGO

382

Chap. 48:50 *Motor Vehicles and Road Traffic*

[Subsidiary] *Port-of-Spain Transit Centre (Public Service Vehicle Station) Regulations*

Holding Bay. **7.** (1) Public service vehicles whilst in the Holding Bay shall be parked in the manner prescribed by an authorised officer of the Corporation.

(2) An owner or operator of a public service vehicle shall only cause his vehicle to leave the Holding Bay for the purpose of answering calls according to its priority of position.

(3) On the departure of any public service vehicle from the Holding Bay, the vehicle immediately behind it shall move forward and occupy the vacant space and in the like manner other vehicles in the rear shall move forward in the line and occupy the vacant spaces immediately in the front of them.

Ready Bay. **8.** (1) An owner or operator of a public service vehicle shall only cause his vehicle to enter the Ready Bay for the purpose of answering calls according to its priority of position.

(2) An owner or operator of a public service vehicle shall not cause his vehicle to leave the Ready Bay until instructed to do so by an authorised officer of the Corporation.

Loading Bay. **9.** Upon leaving the Ready Bay, an owner or operator shall, prior to loading, hand in his position number to an authorised officer located in the area so designated, and then take his vehicle to the Loading Bay as indicated by its position number.

Refusal of passenger. **10.** An owner or operator shall not refuse to take up any passenger bound for any destination stated on a Loading Bay without reasonable excuse.

Cancellation or suspension of permits. **11.** The Manager may suspend or cancel the permit of any owner, operator or conductor upon being satisfied that such owner, operator or conductor is—
(a) a persistent offender; or
(b) otherwise deemed unfit by the Manager to hold a permit.

Appeals. **12.** The Corporation shall hear and determine any appeal submitted by an aggrieved person against any decision to cancel or suspend his permit and the decision of the Corporation thereon shall be final and conclusive.

LAWS OF TRINIDAD AND TOBAGO

Motor Vehicles and Road Traffic

Chap. 48:50

383

Port-of-Spain Transit Centre (Public Service Vehicle Station) Regulations

[Subsidiary]

13. All users of the Transit Centre shall be required to observe such operating conditions as shall be prescribed by the Corporation from time to time. General.

14. An owner, operator or conductor who contravenes any of these Regulations shall be guilty of an offence and liable on summary conviction to a fine of five hundred dollars for a first Offence and one thousand dollars for each subsequent offence. Offence.

LAWS OF TRINIDAD AND TOBAGO

384

Chap. 48:50 *Motor Vehicles and Road Traffic*

[Subsidiary] *Port-of-Spain Transit Centre (Public Service Vehicle Station) Regulations*

[Regulation
4(1)].

SCHEDULE

FORM 1

**PUBLIC TRANSPORT SERVICE CORPORATION
PORT-OF-SPAIN TRANSIT CENTRE FACILITY**

Form of particulars to be given by Applicant for Registration for a Public Service Vehicle Permit to use Transit Centre

1	Full name of owner	
2	Postal address or residence of owner	
3	Full name of driver/operator (1)	
4	Postal address of driver/operator (1)	
5	Full name of driver/operator (2)	
6	Postal address of driver/operator (2)	
7	Description or type of vehicle	
8	Type and colour of body and seating accommodation	
9	Make of vehicle and year of manufacture	
10	Chassis number	
11	Registration number	
12	Name of Company with which insured	
13	Number of policy	
14	Date policy expires	
15	Weight for registration purposes	
16	Are you the registered owner of a Maxi-Taxi?	
17	State are you the holder of a permit to operate a Maxi-Taxi	
18	If yes, state registration certificate/permit number and date of issue	

.....
Date

.....
Signature

N.B: It is an offence under the Motor Vehicles and Road Traffic Act, Ch. 48:50 to give any particulars which are not correct and you will be liable to prosecution if you do so.

LAWS OF TRINIDAD AND TOBAGO

Motor Vehicles and Road Traffic

Chap. 48:50

385

Port-of-Spain Transit Centre (Public Service Vehicle Station) Regulations

[Subsidiary]

FORM 2

[Regulation 4(2)].

PUBLIC TRANSPORT SERVICE CORPORATION

(FRONT)

PHOTOGRAPH	REPUBLIC OF TRINIDAD AND TOBAGO		
	TRANSIT CENTRE PASS CONDUCTOR/ OWNER/OPERATOR/DRIVER		
	Issue Date	Expiry Date	
	Birth Date	Sex	Class
	Permit Number		Date of Payment
Classification:		<input type="checkbox"/> Owner <input type="checkbox"/> Operator/Driver <input type="checkbox"/> Conductor	
SIGNATURE OF HOLDER	AUTHORISED SIGNATURE		

LAWS OF TRINIDAD AND TOBAGO

386

Chap. 48:50 *Motor Vehicles and Road Traffic*

[Subsidiary] *Port-of-Spain Transit Centre (Public Service Vehicle Station) Regulations*

FORM 2—Continued

PUBLIC TRANSPORT SERVICE CORPORATION

(BACK)

Reminder Notice

This Permit is valid for one (1) year from the date of First Issue or Anniversary

Date of Renewal.

NOTES

Transaction Code:

- A FIRST ISSUE
 - B RENEWAL
 - C DUPLICATE
 - D ENDORSEMENT
-

LAWS OF TRINIDAD AND TOBAGO

Motor Vehicles and Road Traffic

Chap. 48:50

387

Port-of-Spain Transit Centre (Public Service Vehicle Station) Regulations

[Subsidiary]

FORM 3

[Regulation 4(4)].

**PUBLIC TRANSPORT SERVICE CORPORATION PORT-OF-SPAIN
TRANSIT CENTRE FACILITY**

RENEWAL OF TRANSIT CENTRE PASS

1	Type of Pass applied for	[] Motor vehicle [] Conductor
2	Full name of applicant	
3	Sex	
4	Place of Birth	
5	Date of Birth	
6	Nationality	
7	Residential Address	
8	Postal address if different from above	
9	Are you the holder of a Transit Centre Pass?	[] Yes [] No
	Have you previously been the holder of a Transit Centre Pass?	[] Yes [] No
	If yes, state number and date of issue	
	Maxi-Taxi Registration No.	
10	Give particulars of any pass which you held or now hold	
11	Have you at any time been disqualified from obtaining a Transit Centre Pass?	[] Yes [] No
12	If yes, give particulars	

.....
Date

.....
Signature of Applicant

N.B.: It is an offence under the Motor Vehicles and Road Traffic Act, Ch. 48:50 to give any particulars which are false or in any material respect misleading and you will be liable to prosecution if you do so.

LAWS OF TRINIDAD AND TOBAGO

388

Chap. 48:50 Motor Vehicles and Road Traffic

[Subsidiary] Port-of-Spain Transit Centre (Public Service Vehicle Station) Regulations

FORM 3—Continued

(BACK)

DECLARATION IN RESPECT OF APPLICATION FOR
DUPLICATE TRANSIT CENTRE PASS FOR OWNER/
OPERATOR/DRIVER/CONDUCTOR

I of
.....

in the Republic of Trinidad and Tobago do solemnly and sincerely declare as follows:

1. I am the holder of No.
which was issued/renewed for the year 20.....

2. The said No. was lost or
stolen, on or about the day of.....
and although I have made a diligent search for the said
..... I have been unable to find same.

3. The said No. was destroyed on or
about the day of 20

And I make this declaration conscientiously believing the same to be true and according to the Statutory Declarations Act, Ch. 7:04 and I am aware that if there is any statement in this declaration which is false in fact, which I know or believe to be false or do not believe to be true I am liable to fine and imprisonment.

Declared at
this day of 20

Before Me,

.....
Commissioner of Affidavits

LAWS OF TRINIDAD AND TOBAGO

Motor Vehicles and Road Traffic

Chap. 48:50

389

Port-of-Spain Transit Centre (Public Service Vehicle Station) Regulations

[Subsidiary]

FORM 4

[Regulation 6(2)].

PUBLIC TRANSPORT SERVICE CORPORATION
PORT-OF-SPAIN TRANSIT CENTRE FACILITY

Form of Particulars to be given by Applicant for Conductor's Permit

Table with 2 columns and 6 rows. Row 1: Full name of applicant. Row 2: Postal address or residence of applicant. Row 3: State date of birth of applicant. Row 4: Are you the holder of a conductor's permit, or have you at any time previously been the holder of a conductor's permit, if so state number and date of issue. Row 5: State particulars of any endorsement on any conductor's or driver's permit which you hold or have. Row 6: Have you at any time been disqualified from obtaining a conductor's or driver's permit? If so, give particulars as to the Court by whom, the date on which and the period for which the disqualification was imposed.

.....
Date

.....
Signature

N.B.: It is an offence under the Motor Vehicles and Road Traffic Act, Ch. 48:50 to give any particulars which are not correct and you will be liable to prosecution if you do so.

**PRIORITY BUS ROUTE
(TRAFFIC CONTROL) ORDER**

ARRANGEMENT OF CLAUSES

CLAUSE

1. Citation.
2. Conditional use of route.
3. No left turn—eastbound traffic.
4. No left turn—westbound traffic.
5. No right turn—eastbound traffic.
6. No right turn—westbound traffic.
7. Stopping prohibited.
8. Offence.

**PRIORITY BUS ROUTE
(TRAFFIC CONTROL) ORDER**

99/1988.

made under section 65

1. This Order may be cited as the Priority Bus Route (Traffic Control) Order. Citation.

2. Drivers of maxi-taxis and other vehicles authorised by the Minister may use the Priority Bus Route (hereinafter called “the Route”) subject to the following conditions: Conditional use of route.

(a) drivers proceeding westwards may enter the Route at—

(i) Five Rivers, Arouca and exit at Orange Grove Road, Tunapuna; and

(ii) Sargeant Street East, Tunapuna and exit into Port-of-Spain via Abattoir Road, West of the flyover bridge;

(b) drivers proceeding eastwards may enter the Route at—

(i) Abattoir Road, West of the flyover bridge, Port-of-Spain and exit in Tunapuna via Sargeant Street West; and

(ii) Orange Grove Road, Tunapuna and exit at Five Rivers, Arouca;

(c) no driver shall park along the Route; and

(d) drivers of maxi-taxis shall ply for hire at designated maxi-taxi stops only.

3. (1) Drivers proceeding eastwards along the Route shall not turn left at the following intersections: No left turn—eastbound traffic.

(a) Croisee, San Juan;

(b) Curepe, except for drivers of PTSC buses; and

(c) Scott Street.

(2) Drivers of maxi-taxis proceeding eastwards along the Route shall not turn left at Centenary Street, Tunapuna.

LAWS OF TRINIDAD AND TOBAGO

392

Chap. 48:50

Motor Vehicles and Road Traffic

[Subsidiary]

Priority Bus Route (Traffic Control) Order

No left turn—
westbound
traffic.

4. Drivers proceeding westwards along the Route shall not turn left at the following intersections:

- (a) Aranguez Road;
- (b) Sixth Avenue.

No right turn—
eastbound
traffic.

5. Drivers proceeding eastwards along the Route shall not turn right at the following intersections:

- (a) Sixth Avenue;
- (b) Aranguez Road.

No right turn—
westbound
traffic.

6. (1) Drivers proceeding westwards along the Route shall not turn right at the following intersections:

- (a) Scott Street;
- (b) Curepe;
- (c) Croisee, San Juan; and
- (d) Abattoir Road, West of the flyover.

(2) Drivers of maxi-taxis proceeding westwards along the Route shall not turn right at Centenary Street, Tunapuna.

Stopping
prohibited.

7. Drivers shall not stop along the Route within a distance of—

- (a) one hundred metres in either direction from any intersection; or
- (b) one hundred metres in either direction from any bus terminus,

except that drivers of maxi-taxis may stop at the designated maxi-taxi stops.

Offence.

8. A driver who contravenes this Order is guilty of an offence and is liable on summary conviction to a fine of five hundred dollars or imprisonment for three months.

**PRIORITY BUS ROUTE
(SPECIAL ROADS TOLL) REGULATIONS**

ARRANGEMENT OF REGULATIONS

REGULATION

1. Citation.
 2. Definitions.
 3. Prohibition.
 4. Application to the Minister.
 5. Tolls.
 6. Duration of permit.
 7. Permit subject to conditions.
 8. Penalty.
-

[Subsidiary]

75/1988.

**PRIORITY BUS ROUTE
(SPECIAL ROADS TOLL) REGULATIONS**

made under section 100 (n)

Citation. **1.** These Regulations may be cited as the Priority Bus Route (Special Roads Toll) Regulations.

Definitions. **2.** In these Regulations—
“applicant” means an owner who applied to the Minister under regulation 4 for permission to operate a maxi-taxi on the Priority Bus Route;

“owner” means the owner of a maxi-taxi;

Ch. 48:50. “Licensing Authority” has the meaning assigned to it by the Motor Vehicles and Road Traffic Act;

Ch. 48:01. “Route” means the Priority Bus Route classified under section 3 of the Highways Act;

“quarter” means a period of three months or less expiring on 31st March; 30th June; 30th September or 31st December;

“toll” means the fee payable for a permit issued under regulation 5(1).

Prohibition. **3.** No owner shall operate or cause to be operated, his maxi-taxi along the Route unless he is in possession of a permit issued by the Minister authorising him to do so.

Application to the Minister. **4.** An owner who is desirous of operating his maxi-taxi along the Route shall apply in writing to the Minister for a permit to do so.

Tolls. **5.** (1) The successful applicant shall receive a permit issued by the Minister upon payment of a toll in the amount of three hundred dollars.

(2) The toll referred to in subregulation (1) is payable in advance by the owner to the Licensing Authority and is non-refundable.

LAWS OF TRINIDAD AND TOBAGO

Motor Vehicles and Road Traffic

Chap. 48:50

395

Priority Bus Route (Special Roads Toll) Regulations

[Subsidiary]

6. The grant of a permit is for the duration of one quarter and is renewable upon application by the owner in accordance with regulation 4. Duration of permit.

7. The Minister may attach to the grant of the permit such conditions as he thinks fit. Permit subject to conditions.

8. An owner who contravenes these Regulations is guilty of an offence and liable on summary conviction to a fine of two hundred and fifty dollars. Penalty.
